

CF 1200 Spot

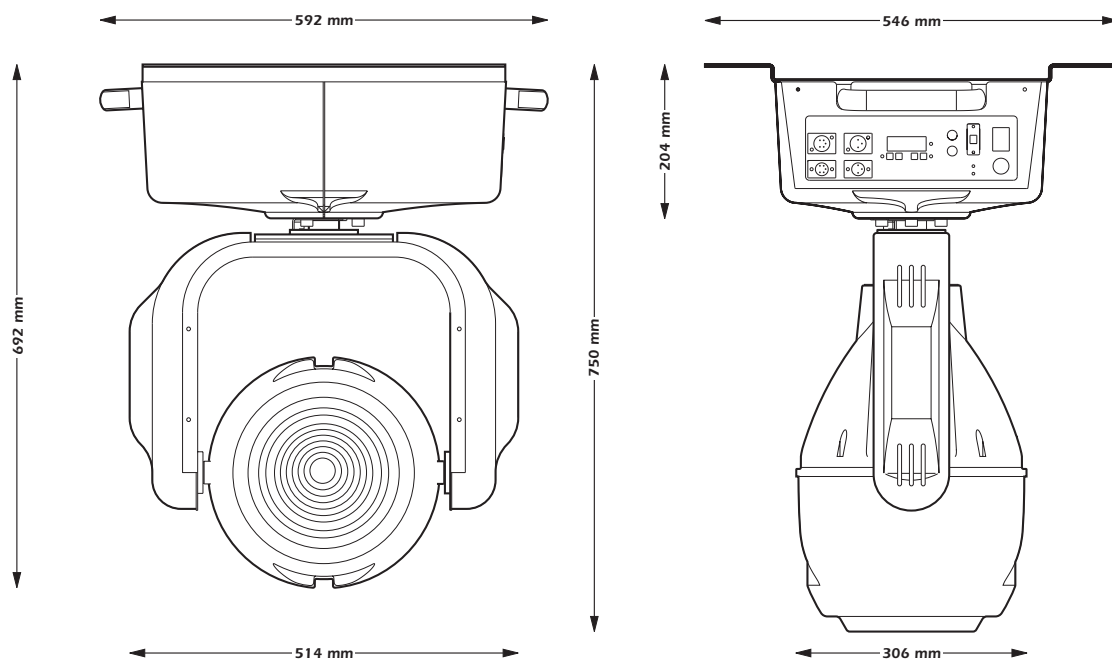

serial number _____

date of purchase _____

retailer _____

address _____

suburb _____

capital city _____

state _____

tel./fax/ _____

*Please note in the space provided above the relative service information of the model and the retailer from whom you purchased your **CF 1200 Spot**: This information will assist us in providing spare parts, repairs or in answering any technical enquiries with the utmost speed and accuracy.*

WARNING: the security of the fixture is granted only if these instructions are strictly followed; therefore it is absolutely necessary to keep this manual.

Index

- 1. Packaging**
- 2. Transporting**
- 3. Important safety information**
- 4. Lamp: installation and replacement**
- 5. Operating voltage and frequency**
- 6. Mounting the unit**
- 7. Mains connection**
- 8. Signal connection**
- 9. Powering up**
- 10. DMX addressing**
- 11. Display panel functions**
- 12. Control channel functions from a DMX 512 controller**
- 13. Aligning the lamp in the optical system**
- 14. Interchanging dichroic colours on the colour wheel**
- 15. Automatic internal functions**
- 16. Maintenance**
- 17. Electronic alignment of the motors**
- 18. Spare parts**
 - Authorised coemar service centres**

Congratulations on having purchased a new **coemar** product; you have assured yourself of a fixture of the highest quality, both in the components used and in the technology. We renew our request to you to complete the service information on the preceding page, to expedite any request for information, or for service (in case of problems encountered either during, or subsequent to, installation). This information will assist in prompt and accurate advice from your authorised **coemar** service centre.

1. Packaging

Following the instructions contained in this manual will ensure the maximum efficiency of this product for years to come.

Open the packing and ensure that no part of the equipment has suffered damage in transit. In the case of damage to the equipment, contact the carrier immediately by telephone or fax, following this with formal notification in writing.

packing list

Ensure that the packaging contains:

- 1 **CF 1200 Spot**
- 1 **instruction manual**

2. Trasporting

The **CF 1200 Spot** should always be transported in its original packaging or in a **coemar** approved flight case.

In order to manufacture a suitable flight case, we recommend the following simple procedures be followed which will stop the articulated movement of the **CF 1200 Spot** during transportation.

Below are illustrated the 2 diverse methods of padding which **coemar** recommends.

A) Padding around the entire projector, including the base, with suitable padding materials.

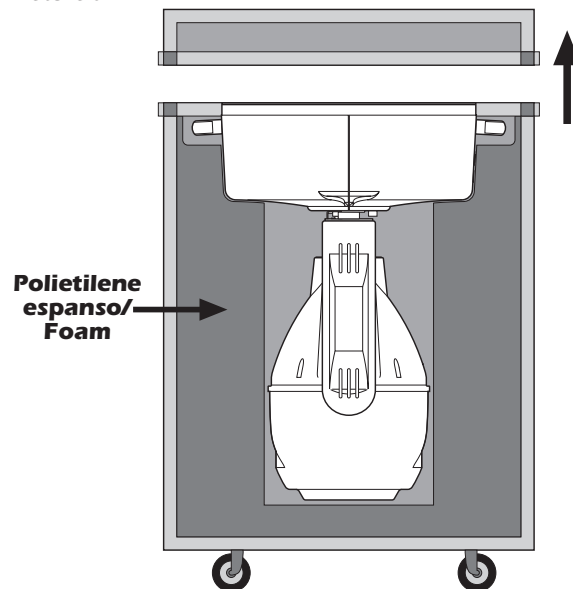

B) Fixing the base to a rigid support, with padding surrounding the articulated head.

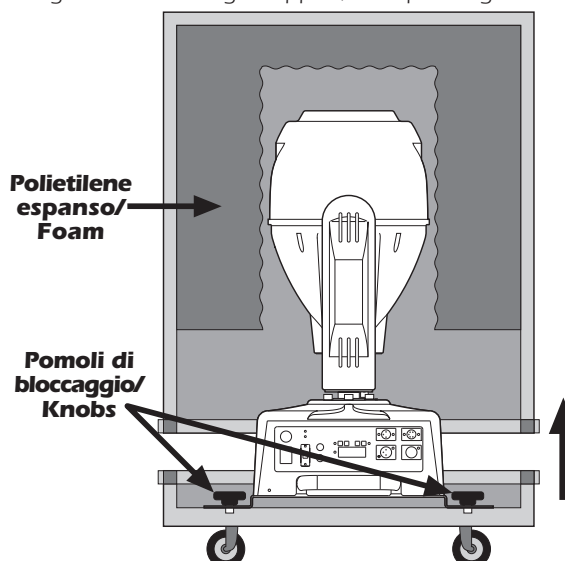

3. Important safety information

Fire prevention

1. **CF 1200 Spot** uses a Philips MSR 1200 SA lamp; the use of any alternative lamp is not recommended and will null and void the fixture's warranty.
2. Never locate the fixture on any flammable surface
3. Minimum distance from flammable materials: 0.5 m.
4. Minimum distance from the closest illuminable surface: 2 m.
5. Replace any blown or damaged fuses only with those of identical values. Refer to the schematic diagram if there is any doubt.
6. Connect the projector to mains power via a thermal magnetic circuit breaker.

Prevention of electric shock:

1. High voltage is present in the internals of the unit. Isolate the projector from mains supply prior to performing any function which involves touching the internal of the unit, including lamp replacement.
2. For mains connection, adhere strictly to the guidelines outlined in section 7 of this manual.
3. The level of technology inherent in the **CF 1200 Spot** requires the use of specialised personnel for all service applications; refer all work to your authorised **coemar** service centre.
4. A good earth connection is essential for proper functioning of the projector. The projector should never be operated without proper earth connection.
5. The fixture should never be located in an exposed position, or in areas of extreme humidity. A steady supply of circulating air is essential.

Protection against ultraviolet radiation:

1. Never turn on the lamp if any of the lenses, filters, or the carbon fibre housing is damaged; their respective functions will only occur efficiently if they are in perfect working order.
Never look directly into the lamp when it is operating.

Safety:

1. The projector should always be installed with bolts, clamps, and other fixings which are suitably rated to support the weight of the unit.
2. Always use a secondary safety chain of a suitable rating to sustain the weight of the unit in case of the failure of the primary fixing point.
3. The external surface of the unit, at various points, may exceed 150°C. Never handle the unit until at least 10 minutes after the lamp has been turned off.
4. Always replace the lamp if any physical damage is evident.
5. Never install the fixture in an enclosed area lacking sufficient air flow; the ambient temperature should not exceed 35°C.
6. The hot lamp may explode, always wait at least 10 minutes after it has been turned off prior to attempting to replace or handle the lamp.
Always wear suitable hand protection when handling the lamp.

4. Lamp: Installation and replacement

CF 1200 Spot utilises a 1200 W Philips MSR 1200 SA lamp with a GY 22 lamp base

The lamp is available from your authorised **coemar** sales agents:

coemar cod.	105090/1
wattage	1200 w
luminous flux	96.000 lm
colour temperature	6500° K
base	GY 22
approximate life	500 hours

Attention

Disconnect mains power prior to inspecting the unit internally.

The fixture's internal temperature can reach 250° C after 5 minutes, with a maximum peak of 350° C; ensure that the bulb is cold before attempting removal. The fixture should be allowed to stand and cool for 10 minutes prior to its removal.

MSR/SA lamps are part of the mercury vapour family of discharge lamps and must be handled with great care. The lamp operates at high pressure, and the slight risk of explosion of the lamp exists if operated over its recommended life of 500 hours.

We recommend, therefore, that the lamp be replaced within the manufacturer's specified lamp life.

Lamp installation

- 1) With the use of a 3mm Allen Key, loosen the two bolts (**A**) which fix the lamp assembly to the body of the projector.

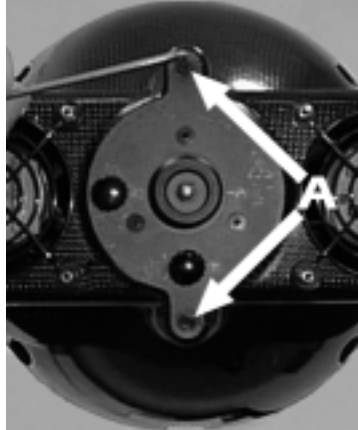

- 2) Remove the lamp assembly (**B**).



- 3) Locate the lampholder (**C**)



- 4) Insert the lamp (**D**). The lamp used is manufactured from quartz glass and should be handled with care; always adhere to the instructions supplied in the lamp's packaging. Do not touch the glass directly, use the tissue provided in the lamp's packaging. The GY 22 lampholder is asymmetrical in construction. One lamp pin is larger than the other; therefore make sure that the lamp's pins are correctly aligned in the lampholder. If you encounter difficulty during this operation, DO NOT USE UNDUE FORCE. Re-read the instructions and repeat the procedure.



- 5) Replace the lamp assembly (**B**) in its original position and replace the two bolts (**A**) which were previously removed.

Attention: we recommend that the lamp be realigned in the optical train of the unit to avoid overheating the dichroic filters within the unit; refer to section 13 for instructions about this procedure.

5. Operating voltage and frequency

coemar factory presets (barring specific requests), a voltage of 230v to 240v selectable via a switch on the base of the **CF 1200 Spot**.

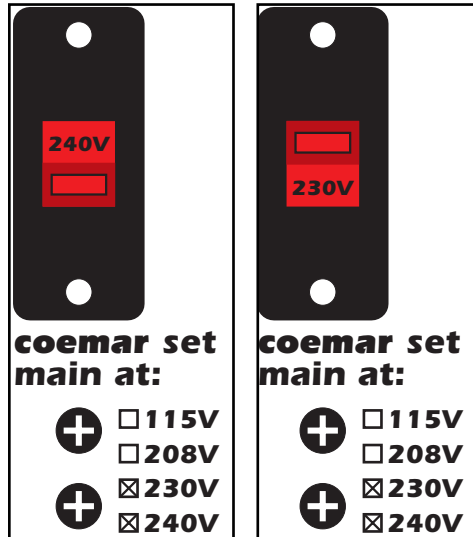

Remember to set the selector (230 or 240V) to the selection which most closely matches the operating voltage at your venue.

If your operating voltage is 208V, this may be selected internally by shifting the cable labelled 21 (connected to the 240V position of the switch) or cable 22 (connected to the 230V switch), thereby, however, eliminating the ability to select either 230V or 240V.

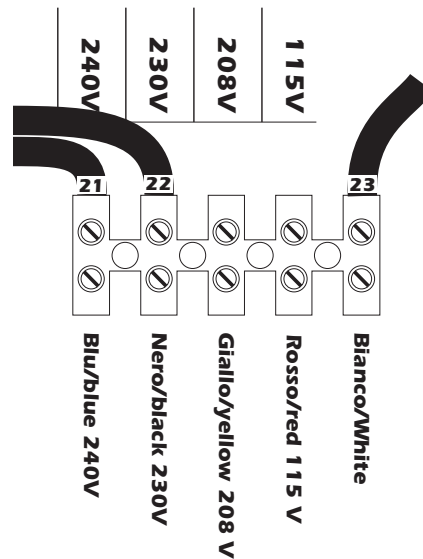

Incorrect voltage selection will detrimentally affect the operation of the projector. Under no circumstances should cable 23 be moved.

CF 1200 Spot is fitted with an electronic ballast which automatically adjusts the output voltage to the projector when the input voltage is in the range of 180 to 260V; it is therefore not necessary to make any modifications when moving to venues with power supplies in this range.

6. Mounting the unit

mounting

CF 1200 Spot may be floor or ceiling mounted.

The structure from which the unit is hung should be of sufficient rating to hold the weight of the unit, as should any clamps used to hang the unit.

The structure should also be sufficiently rigid so as not to move or shake whilst the **CF 1200 Spot** moves during its operation.



The mounting holes in the base of the unit allow it to be mounted at various angles to the mounting truss, and to trusses of various dimensions.

The following is a diagram of the base of the **CF 1200 Spot**.

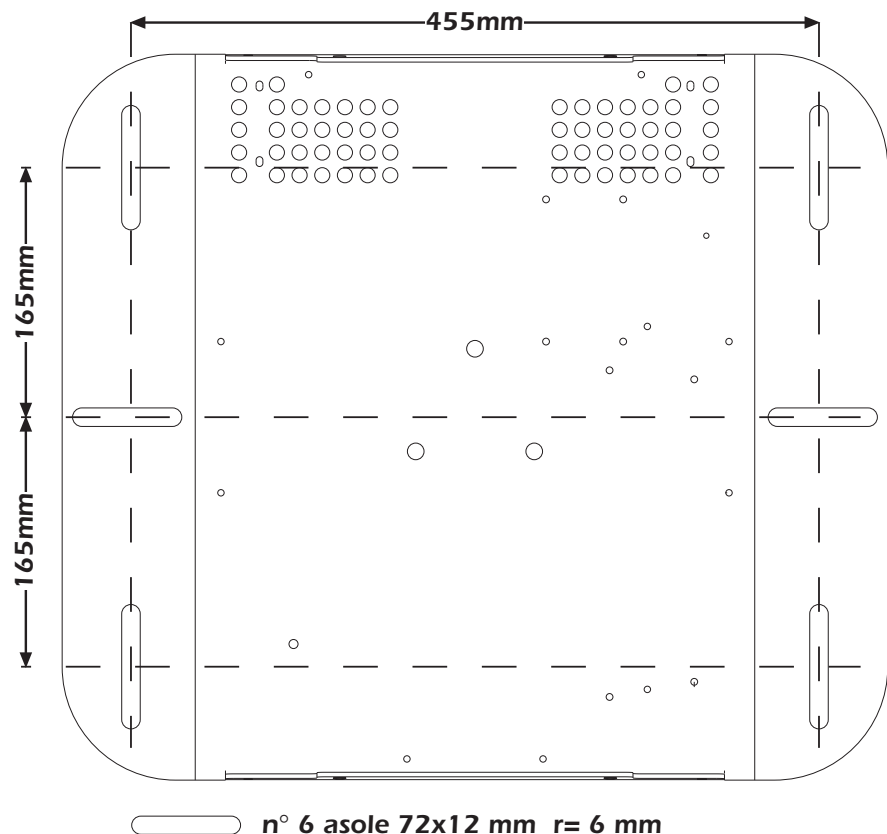

In order to obtain maximum efficiency of movement, the unit should be mounted with the " Front" label facing the main illumination point.



protection against liquids

The projector contains electric and electronic components that must not come into contact with water, oil, or any other liquid.

movement

The projector has a movement of 370° in the base and 270° in the yoke; **DO NOT** place any obstructions in the path of the projector's movements.

safety chain

The use of a safety chain (cod. 069) - fixed to the **CF 1200 Spot** and to the primary suspension point, is highly recommended to protect against accidental failure, however unlikely, of the primary suspension point.

If using an after-market safety chain, not manufactured by **coemar**, ensure that it is of sufficient strength to hold the weight of this fixture.

risk of fire

Each fixture produces heat and must be installed in a well-ventilated position. The minimum recommended distance from flammable material is: 0.5m. Minimum distance from the object being illuminated is: 2m.

7. Mains connection

cabling

The mains cable provided is thermally resistant, complying to the most recent international standards. It meets or exceeds the VDE and IEC norms, IEC 331, IEC 332 3C, CEI 20 35.

NB: In the case of cable replacement, similar cable, with comparable thermal resistant qualities must be used exclusively (cable 3x1,5 \varnothing external 10 mm, rated 300/500V, tested to 2KV, operating temperature $-40^{\circ} +180^{\circ}$, **coemar** cod. CV5309).

mains connection

CF 1200 Spot can operate at voltages from 208V-230V-240V at 50 or 60Hz (operating voltage and frequency can be selected as described in section 5 of this manual).

Prior to connecting the unit to your mains supply, ensure that the model in your possession correctly matches the mains supply available to you.

For connection purposes, ensure your plug is of a suitable rating: 9,5 amps.

Locate the mains cable which exits the base of the unit and connect as shown below:

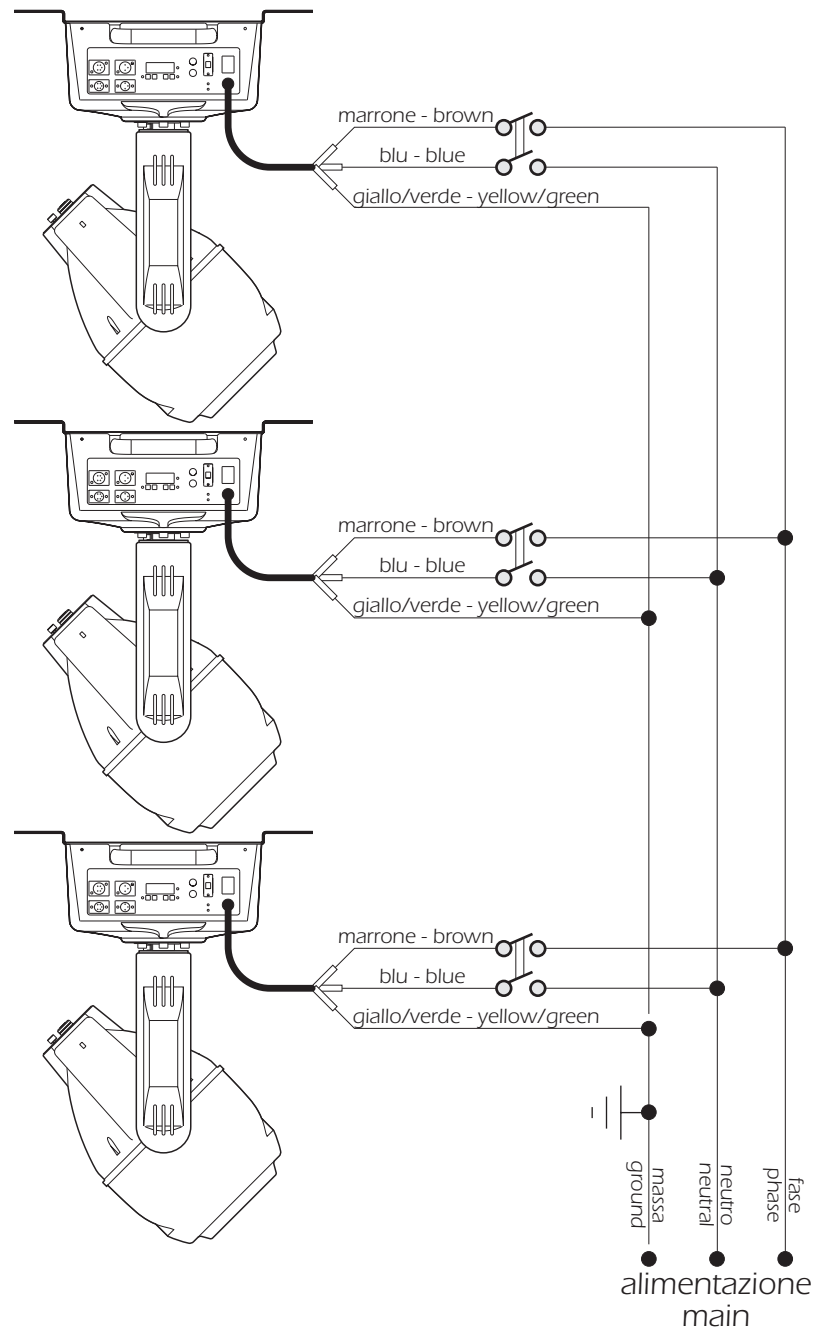

protection

The use of a thermal magnetic circuit breaker is recommended for each **CF 1200 Spot**.

A good earth connection is essential for the correct operation of the fixture. Strict adherence to regulatory norms is strongly recommended.



ATTENTION!, DANGER!



The electronic ballast with which the **CF 1200 Spot** is fitted, as with other electronic devices, requires a correct dimension for the neutral conductor, since the current in the neutral conductor is equal to the sum of the current in all the active conductors.

For example, if at the mains outlet a current of 10Amps is on phase R, 10Amps on phase S, and 10Amps on phase T, a total current of 30 Amps exists in the neutral.

Please note the above to ensure the correct selection of cable dimensions. Qualified electrical personnel should always be consulted.

CF 1200 Spot requires a proper earth connection to operate safely and correctly. Never operate the fixture unless the green/yellow conductor is connected.

8. Signal connection

Control signal is digital and is transmitted via two pair screened $\varnothing 0,5\text{mm}$ cable. Connection is serial, using the XLR 3 or XLR5 male and female sockets set on the rear part of the **CF 1200 Spot**, labelled **DMX 512** and **DMX 512 standard** (see diagram).

Connection is to international standards:

pin 1= screening 0 volts	pin 4= not connected
pin 2= data -	pin 5= not connected
pin 3= data +	

A connection via 5 Pin XLR 5

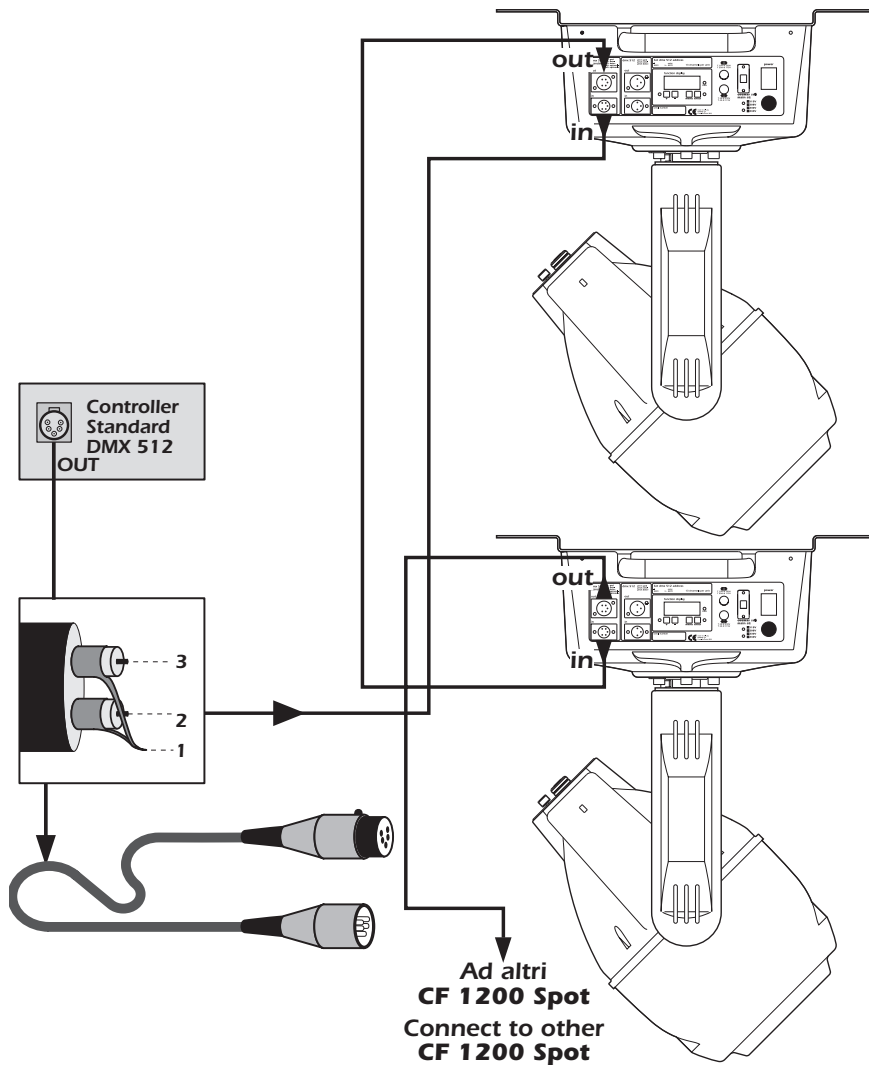

B connection via 3 Pin XLR 3

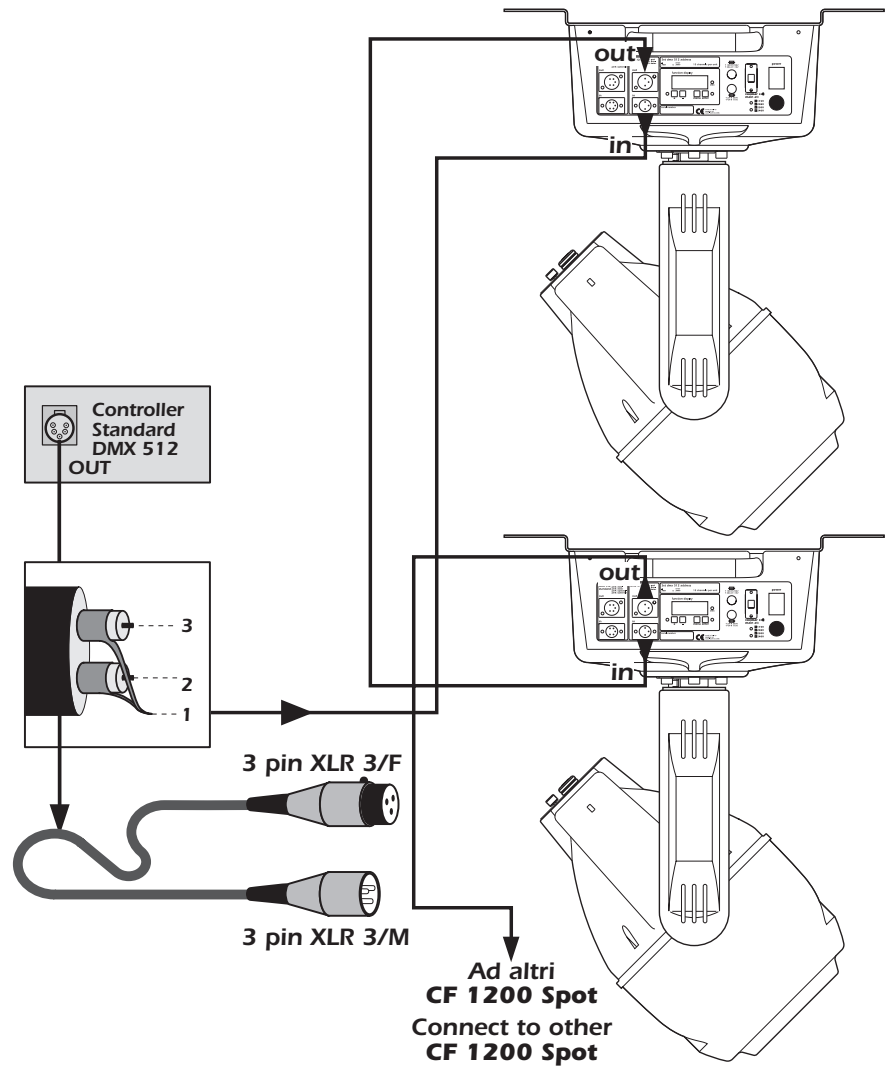

Ensure that all data conductors are isolated from one another and the metal housing of the connector

Make sure that the XLR 3 or 5 pins are isolated form the metal housing of the cannon connector.

9. Powering up

After having followed the preceding steps, turn on the **DMX 512** controller which will be used to control the **CF 1200 Spot**. Then turn on the power to the projector and turn on the **power** switch. The projector will perform a reset function on all the internal and external motors. This will last some few seconds, after which it will be subject to the external signal from the controller.

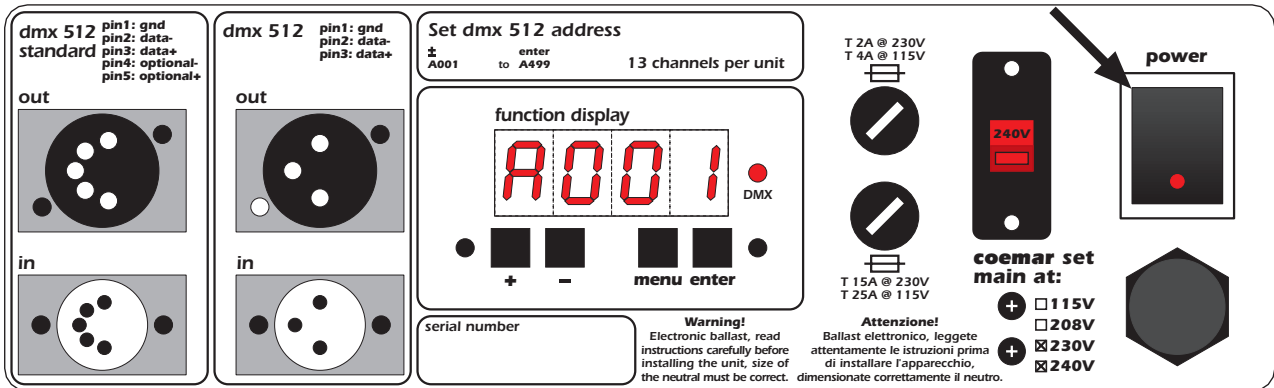

DMX led

The DMX led will be static on to indicate **DMX 512** signal is being correctly received by the projector.

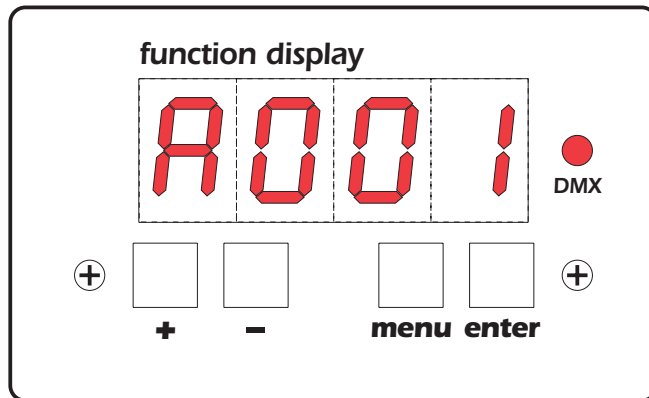

If the led is off, the projector is not receiving signal. Check the cabling and the functioning of the controller.

10. DMX addressing

Each **CF 1200 Spot** utilises **13 channels** of **DMX 512** signal for complete control. To ensure that each projector accesses the correct signal, it is necessary to correctly address each fixture. Any number between 1 and 495 can be generated via the rear multi-function panel of the **CF 1200 Spot**.

When powered up initially, each projector will display **A001** which indicates **DMX** address **1**; a projector thus addressed will respond to commands on channels **1** through **13** from the DMX 512 controller, a second projector should be addressed as **14**, a third as **27** and so on.

altering DMX addresses

- 1) Press the **+** or **-** buttons until the desired **DMX** number appears in the LED display. The display will flash, indicating that the selection is not stored in memory.

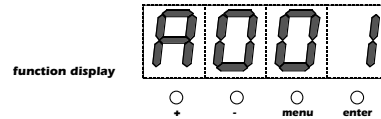

- 2) Press the **enter** button to confirm your selection; the display will stop flashing and the projector will now respond to the new **DMX** address.
- 3) To better understand the function of each channel, we refer you to section 12 "Control channel functions from a DMX 512 controller".

Important Note: Keeping the **+** or **-** pressed down will cause the display to alter at increased speed, allowing a faster selection to be effected.

By pressing the **-** button, you may inadvertently select a DMX address which is not being communicated to by your controller, for example 500; in this case, you will need to either adjust your controller to ensure the DMX address is being communicated to, or you may need to readjust the DMX address of the **CF 1200 Spot**.

11. Display panel functions

The display panel at the rear of the **CF 1200 Spot** is used to display and set function information and various parameters.

Altering the **coemar** factory settings may vary the functioning of the projector, causing it to not respond to external DMX 512 signal. Please read and familiarise yourself with the following information very carefully before altering any selections.

reset

This function carries out a reset in the case, however unlikely, that one or more motors lose their reference points.

- 1) Press the **menu** button
- 2) Press the **+** or **-** buttons till **rESE** (for reset) is displayed.

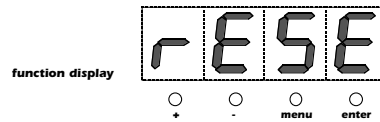

- 3) Press the **enter** button to confirm your selection. The projector will proceed to perform a reset.

rate

This function provides information on the speed or rate of **DMX 512** signal being received by the **CF 1200 Spot**.

- 1) Press the **menu** button
- 2) Press the **+** or **-** buttons till **rAtE** (for rate/speed) is displayed.

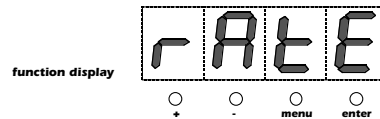

- 3) Press the **enter** button to confirm; the display will show a numerical value which is the rate/speed of the **DMX 512** signal being received.

hour

This function provides information on the number of hours of operation of the **CF 1200 Spot**.

- 1) Press the **menu** button
- 2) Press the **+** or **-** buttons till **HoUr** (for hour) is displayed.

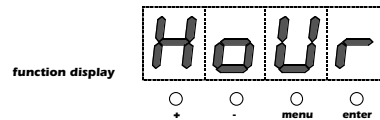

- 3) Press the **enter** button to confirm your selection. The display will show a value which is the length of time which the fixture has been in operation.

life

This function provides information on the number of hours of operation of the lamp in the unit.

- 1) Press the **menu** button.
- 2) Press the **+** or **-** buttons until **LIFE** (for lamp life) is displayed.

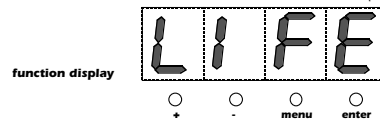

- 3) Press the **enter** button to confirm your selection. The display will show a numerical value which is the length of time in hours that the lamp has been operated since the counter was last reset.

resetting the lamp life counter

The lamp life counter needs to be reset to zero at every lamp change to provide accurate information on lamp life.

- 1) Turn off the projector.
- 2) Whilst holding down the **+** and **-** buttons, turn power back on to the projector.
- 3) Press the **menu** button.

- 4) Press the **+** or **-** buttons until **LIFE** (for lamp life) is displayed.

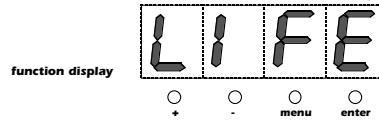

- 5) Press the **enter** button to confirm your selection. The display will show 0000, confirming that the lamp life counter is reset.

dirp

This function inverts the movement for horizontal (pan) movements.

- 1) Press the **menu** button.
- 2) Press the **+** or **-** button until **dirP** (for pan direction) is displayed.

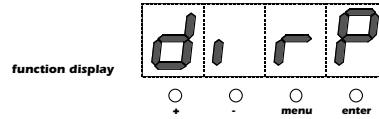

- 3) Press the **enter** button to confirm your selection. The display will show **cw** (for clockwise).

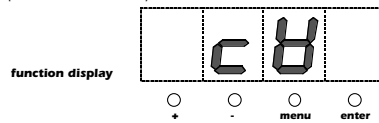

- 4) Press the **+** or **-** until **ccw** (for counterclockwise) is displayed.

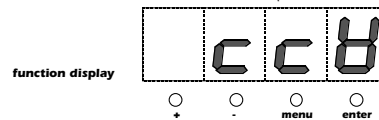

- 5) Press the **enter** button after either step 3 or step 4 to confirm your choice of direction.

dirt

This function inverts the movements for vertical (tilt) movements.

- 1) Press the **menu** button.
- 2) Press the **+** or **-** buttons until **dirt** (for tilt direction) is displayed.

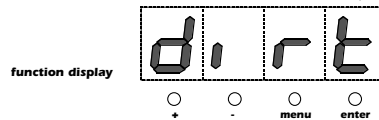

- 3) Press the **enter** button to confirm your selection. The display will show **cw** (for clockwise).

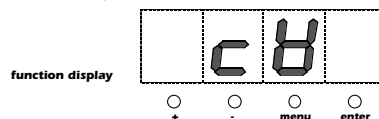

- 4) Press the **+** or **-** until **ccw** (for counterclockwise) is displayed.

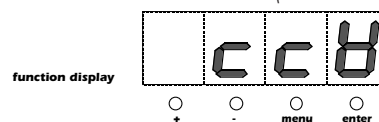

- 5) Press the **enter** button after either step 3 or step 4 to confirm your choice of direction.

oPto

This function allows the sensors which read the instantaneous pan and tilt positions of the fixture to be switched on or off.

With the sensors activated (**opto ON**) the projector will automatically return to its correct position in case it is accidentally moved out of position.

With the sensors inactivated (**opto OFF**) the projector will not return automatically to its correct position if it is accidentally moved out of position.

NOTE: there will be a noticeable difference in the projector at startup; with **opto ON** the reset operation takes but a few seconds; the reset can last up to a minute if **opto OFF** is selected.

- 1) Press the **menu** button.
- 2) Press the **+** or **-** buttons until **oPto** (for optical reader) is displayed.

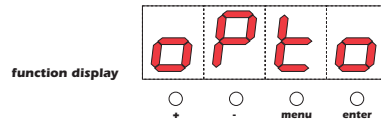

- 3) Press the **enter** button to confirm your selection. The display will show **on** (for opto activated).

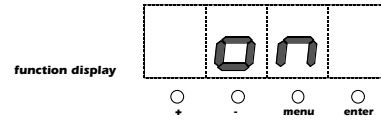

- 4) Press the **+** or **-** buttons until **oFF** (opto deactivated) is displayed.

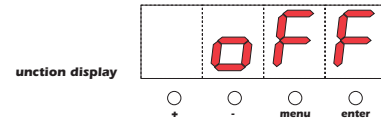

- 5) Press the **enter** button to confirm your selection.

N.B. We recommend that the opto be deactivated only if it is obviously defective and requires replacement.

lamp

This function allows for the on/off control of the lamp via **DMX 512** signal, or for the permanent on (disabling DMX control of this function) of the lamp.

- 1) Press the **menu** button
- 2) Press the **+** or **-** buttons until **LAMP** (for lamp) is displayed.

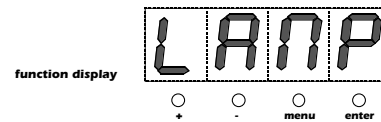

- 3) Press the **enter** button to confirm your selection. The display will show **Strd** (for standard) which corresponds to the standard configuration whereby the lamp can be turned on remotely by bringing channel 13 up to 100%, or off at 0%.

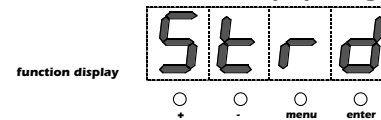

- 4) Press the **+** or **-** buttons until **on** (for on) is displayed. At this setting, the lamp will remain on regardless of the level set on channel 13.

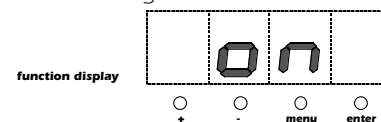

- 5) Press the **enter** button to confirm your selection.

coLr

This function allows the colour wheel to be used in a proportional manner via DMX signal.

- 1) Press the **menu** button
- 2) Press the **+** or **-** buttons until **coLr** (for colour wheel) is displayed.

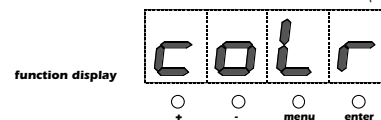

- 3) Press the **enter** button to confirm your selection; the display will show **Strd** (per standard) which corresponds to the automatic centring of the colours on the colour wheel (a change in DMX 512 signal corresponds to a colour change by the **CF 1200 Spot**).

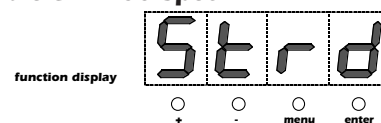

- 4) Press the **+** or **-** buttons; the display will show **SPEc** (for special) which corresponds to the proportional selection of colours on the colour wheel (split colours are possible)

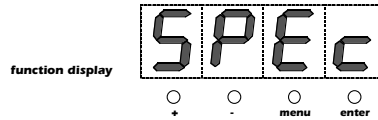

- 5) Press the **enter** button after either step 3 or step 4 to confirm your choice of colour selection.

tEst

This function allows for a test sequence to be carried out on the respective motors of the unit in the absence of any **DMX** signal.

- 1) Press the **menu** button.
- 2) Press the **+** or **-** until **tEst** (for test) is displayed.

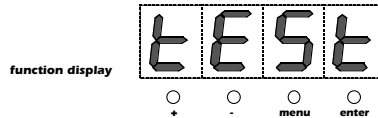

- 3) Press the **enter** button to confirm your selection. The display will show **t 01** (for test number 1). Press the **+** or **-** buttons for each test **t 01** to **t 12**

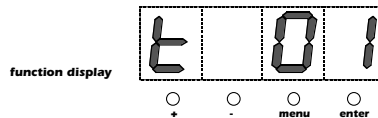

In these tests, the projector simulates the reception of a DMX 512 signal which is increasing from 1 to 255 on the selected channel.

- t 01**= movement in the X-axis
- t 02**= fine movement in the X-axis
- t 03**= movement in the Y-axis
- t 04**= fine movement in the Y-axis
- t 05**= opening/closing of the iris diaphragm
- t 06**= opening/closing the black-out/strobe shutter
- t 07**= opening/closing the frost filter
- t 08**= rotating the effects wheel 1
- t 09**= rotating the colour wheel 1
- t 10**= rotating the cyan dichroic
- t 11**= rotating the magenta dichroic
- t 12**= rotating the yellow dichroic
- t 13**= no effect

- 4) Press the **enter** button to confirm your selection of test to be carried out.

12. Control channel functions from a DMX 512 controller

If all procedures have been correctly carried out to this point, the 13 channels of your **DMX 512** controller will have full control over all the effects available from the **CF 1200 Spot** as described in the following table:

channel	function	type of control	effect	decimal
1	Base (pan) coarse	proportional	coarse control of the base movement	0-255
2	Base (pan) fine	proportional	fine control of the base movement	0-255
3	Yoke (tilt) coarse	proportional	coarse control of the Yoke movement	0-255
4	Yoke (tilt) fine	proportional	fine control of the Yoke movement	0-255
5	dimmer	step	closed	0-7
		proportional	from close to open	8-255
6	shutter	step	closed	0-9
		proportional	strobe effect increasing flash rate	10-127
		proportional	random strobe, increasing flash rate	128-247
		step	open	248-255
7	Beam size	step	white clear	0-9
		proportional	from spot to flood	10-255
8	filter selection	proportional	white clear	0-15
		proportional	filter 1 vertical alteration of adjustable beam angle	16-217
		proportional	filter 3 adjustable	218-255
9	color wheel	step	WHITE	0-24
		step	color 1	25-49
		step	color 2	50-73
		step	color 3	74-99
		step	color 4	100-123
		step	color 5	124-151
		proportional	continuous color wheel rotation clockwise with proportional speed from min. to max.	152-255
NOTE: channel 9 function can be varied selecting color standard/special function on the back function display				
9	color wheel	step	white clear	0- 9
		proportional	proportional 360° color wheel rotation .	10- 151
		proportional	continuous color wheel rotation clockwise with proportional speed from min. to max.	152-255
10	cyan	step	white clear	0-9
		proportional	proportional cyan control from white to cyan	10-255
11	magenta	step	white clear	0-9
		proportional	proportional magenta control from white to magenta	10-255
12	Yellow	step	white clear	0-9
		proportional	proportional yellow control from white to yellow	10-255
13	function	step	lamp off	0-19
		step	pan/tilt go to sensor	20-100
		step	all motor reset	101-240
		step	lamp on	241-255
Back panel can modify function channel (inhibit lamp off)				
13	function	step	lamp on	0-19
		step	pan/tilt go to sensor	20-100
		step	all motor reset	101-240
		step	lamp on	241-255
note 1: 2 or 4 numbers close to the end limit levels cannot be used as unstable levels				
note 2: function channel has a delay time of 6 second to prevent accidental activation.				
note 3 :on/off lamp mode is not affected unless an opposite value is received				

13. Aligning the lamp in the optical system

Aligning the lamp in the optical system is achieved via the three adjusters at the rear of the projector.

This procedure should be undertaken to properly align the lamp in the optical system and to avoid the possible overheating of internal components due to the incorrect focusing of the beam onto components not intended to be exposed to this.

Alignment procedure

Alignment is effected via the three adjusters, **A**, **B** and **C** operating in conjunction with each other; the lamp should be on, black-out and dimmer fully open, and no colour filters inserted.

If the lamp is not correctly aligned, a hot-spot will be noticeable; this is a function of the lamp's positioning; use the three adjusters to bring the hot-spot to the centre of the beam (adjusters **B** and **C**) and then flatten the beam to maximum uniformity (adjuster **A**).

Vertical adjustment

Adjuster (**B**) acts on a lever and spring assembly to position the lamp via a vertical movement within the reflector; rotate it until correct positioning is achieved.

Horizontal adjustment

Adjuster (**C**) acts on a level and spring assembly to position the lamp via a horizontal movement within the reflector; rotate it until correct positioning is achieved.

Axial adjustment

Adjuster (**A**) acts on the entire lamp base support; rotate it until correct positioning is achieved.

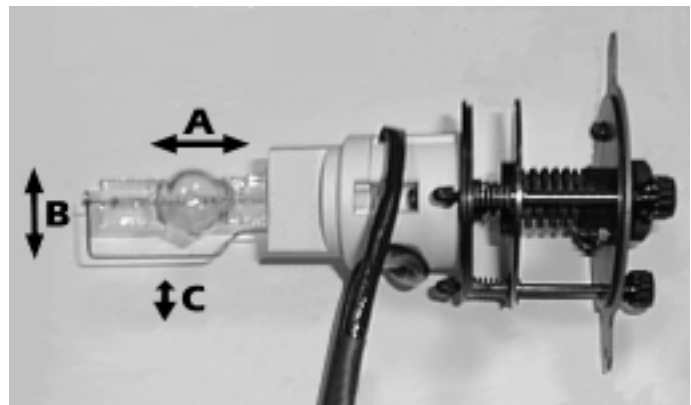
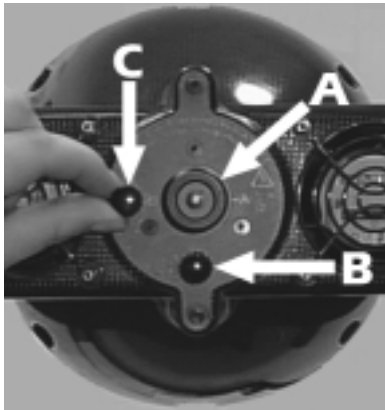

14. Interchanging dichroic colours on the colour wheel

Dichroic filters can be replaced with any colour you require; note that the filter should be sized \varnothing 45mm, thickness 1 mm, and the glass should be tempered (heat-resistant).

Prior to effecting any internal procedure, mains power should be disconnected from the unit.

Attention

Disconnect mains power prior to opening the unit.

replacing a dichroic filter

- 1) Remove the top of the unit by releasing the two latches **A** and remove the top **B** as shown in the diagram.

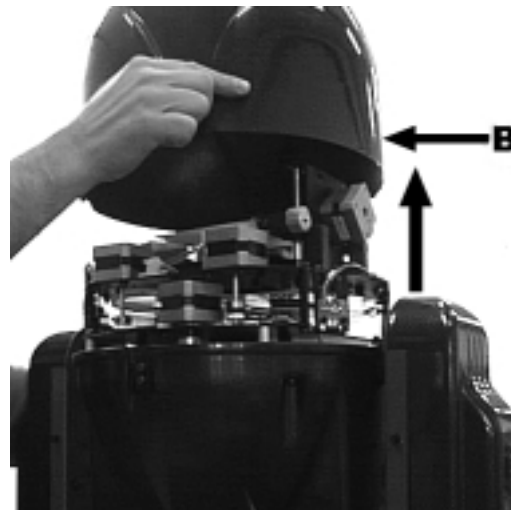

- 2) Locate the interchangeable dichroic colour wheel.

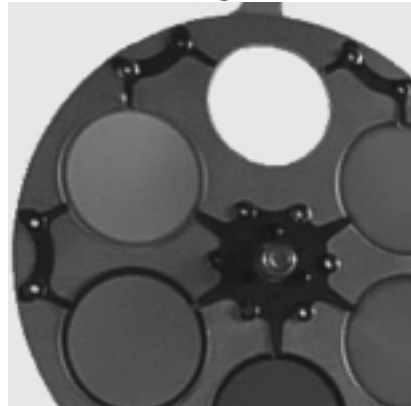

- 3) Rotate the colour wheel manually until to locate the dichroic you wish to remove.

- 4) Remove the filter by lightly pressing on the internal spring clip and sliding the filter towards the centre of the colour wheel.

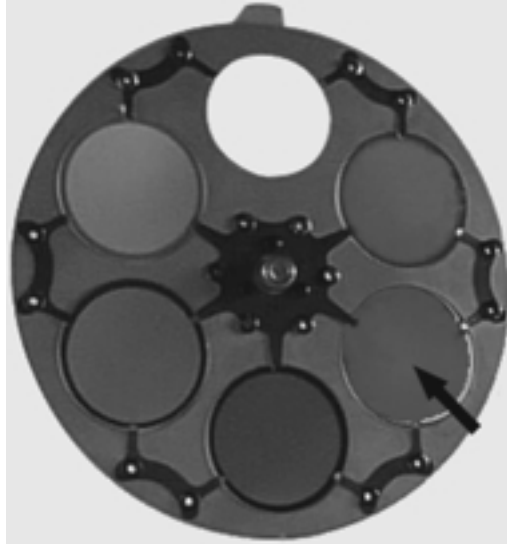

- 6) Slide out the filter.



- 7) Insert a new dichroic filter by sliding the filter gently under the spring clip; lightly press it under the clip and then slide it back under the opposite clip.
8) Replace and re-latch the cover of the **CF 1200 Spot**.

15. Automatic internal functions

CF 1200 Spot has several automatic internal functions which may not be notice at first glance. However, they serve to add functionality to the projector, and to assist in extending the servicability of the unit.

internal timer to prevent restriking a hot lamp

An internal timer is provided to avoid restriking a hot lamp until at least 6 minutes have passed since it was turned off.

This function protects the internal ignitor circuitry for possible damage; it also serves to preserve and protect the lamp itself.

NOTE: the timer is only reset by the projector being switched off.

internal timer to prevent continuous attempts to strike a lamp

An internal timer allows 1 minute for the lamp to be successfully ignited. If after this first minute of attempts, the lamp has not struck, the timer protects the internal ballast and ignitor circuitry by no longer allowing the user to strike the lamp

NOTE: failure of the lamp to strike would indicate that the lamp has reached the end of its operating life. Power should be turned off to the projector (which will reset the timer) and the lamp should be changed.

thermal protection

Two thermal sensors, located in the head and the base of the **CF 1200 Spot** protect the unit from overheating.

The sensors will cause power to the lamp to be switched off if the temperature exceeds the maximum allowable, the may be due to the fixture being located in an area where there is a lack of circulation around the unit, or in the event that a cooling fan within the unit has failed.

automatic realignment

An internal 4 point encoder system allows the **CF 1200 Spot** to return to its correct position in case the unit is accidentally knocked out of alignment whilst operating.

This is particularly useful if the projector is to be mounted on the floor in a position where the performer or artist may accidentally bump the unit.

NOTE: this facility may be deactivated if desired (see section 11).

16. Maintenance

Whilst every possible precaution has been taken to ensure the trouble free operation of your **CF 1200 Spot**, the following periodic maintenance is highly recommended. Before attempting any of the following, ensure that the mains supply to the unit is disconnected.

Attention

Remove mains power prior to opening the unit

Opening the unit

The projector is designed with a removeable front cover which allows complete access to all internal components.

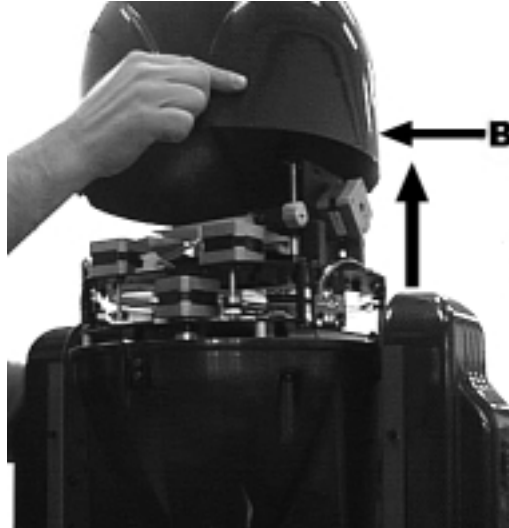

For particular procedures you may remove the 4 screws (**C**), unclip the 8 stepper motor connectors (**D**) the two sensors (**E**) and the thermal contacts (**A**).

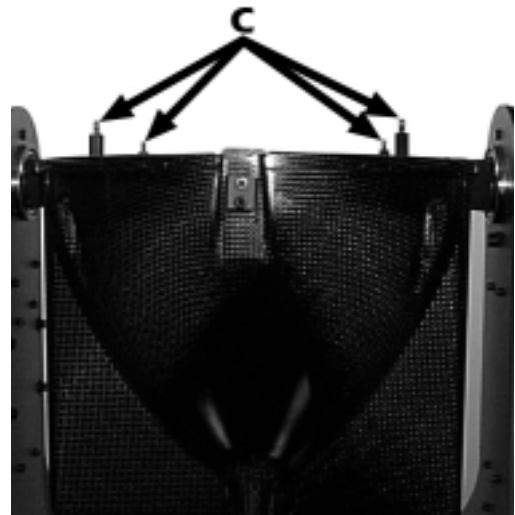

After this simple procedure, the entire motor and effects assembly is able to be removed and any complex procedures carried out.



Replacing the fuse

Locate the fuse which protects the lamp and electronic circuitry in the base of the **CF 1200 Spot**.

Using a multimeter, test the condition of the fuse, replacing it with one of equivalent type if necessary.

Periodic cleaning Lenses and reflectors

Even a fine layer of dust can reduce the luminous output substantially. Regularly clean all lenses and the reflector using a soft cotton cloth, dampened with a specialised lens cleaning solution.

Fans and air passages

The fans and air passages must be cleaned approximately every 6 weeks; the period for this periodic cleaning will depend, of course, upon the conditions in which the projector is operating. Suitable instruments for performing this type of maintenance are a brush and a common vacuum cleaner or an air compressor.

Periodic maintenance

Lamp

The lamp should be replaced if there is any observable damage or deformation due to heat. This will avoid the danger of the lamp exploding.

Mechanicals

Periodically check all mechanical devices for wear and tear; gears, guides, belts, etc., replacing them if necessary.

Periodically check the lubrication of all components, particularly the parts subject to high temperatures. If necessary, lubricate with suitable lubricant (**coemar** cod. **MV 6173/1**)

Electrical components

Check all electrical components for correct earthing and proper attachment of all connectors, refastening if necessary.

17. Electronic alignment of motors

The display panel at the rear of the **CF 1200 Spot** allows for the electronic alignment of the projector's motors. This procedure is performed by **coemar** at the factory. It may be useful to perform this procedure in the case of internal components being replaced.

Altering the **coemar** factory settings may radically alter the functioning of the projector; carefully read all of the following prior to attempting any changes.

Electronic calibration

Important Note: The electronic calibration procedure is only possible if the fixture is receiving **DMX 512** signal.

- 1) Press the **menu** button
- 2) Press the **+** or **-** buttons until **rESE** (for reset) is displayed.

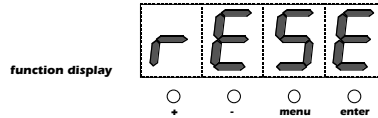

- 3) Press and hold the **enter** button to confirm your selection. Keeping this depressed, simultaneously press and hold the **menu** button, keeping both depressed for at least **30 seconds**. The motors of the fixture will perform a reset, and the display will be as in the following diagram, confirming that you have entered into electronic calibration mode.

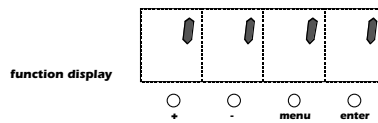

PnAI

- 1) Press the **+** or **-** buttons until **PnAL** (for pan alignment, movement of the base motor of the unit) is displayed.

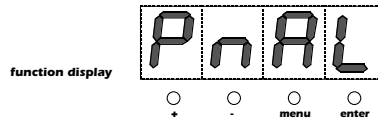

- 2) Press the **enter** button to confirm your selection. The display will show a numerical value which corresponds with the factory setting.

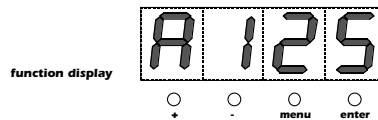

- 3) Press the **+** or **-** buttons until the displayed number corresponds with the correct alignment of the unit (note that with each press of **+** or **-** the motor will move).
- 4) Press the **enter** button to confirm your selection.

tLAL

- 1) Press the **+** or **-** buttons until **tLAL** (for tilt alignment, movement of the yoke) is displayed.

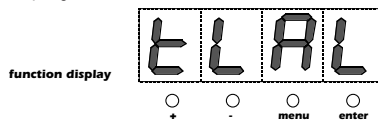

- 2) Press the **enter** button to confirm your selection. The display will show a numerical value which corresponds with the factory setting.

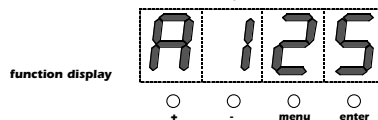

- 3) Press the **+** or **-** buttons until the displayed number corresponds with the correct alignment of the yoke (note that with each press of **+** or **-** the yoke motor will move).
- 4) Press the **enter** button to confirm your selection.

SHAL

- 1) Press the **+** or **-** buttons until **SHAL** (for shutter/black-out alignment) is displayed.

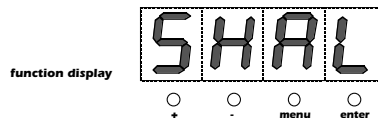

- 2) Press the **enter** button to confirm your selection. The display will show a numerical value which corresponds with the factory setting.
- 3) Press the **+** or **-** buttons until the displayed number corresponds with the correct alignment of the black-out shutter in the optical path of the projector (note that with each press of **+** or **-** the black-out shutter will move).
- 4) Press the **enter** button to confirm your selection.

col1

- 1) Press the **+** or **-** buttons until **col1** (for colour 1 cyan alignment) is displayed.

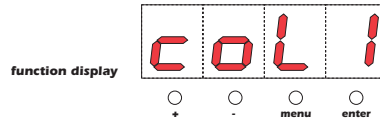

- 2) Press the **enter** button to confirm your selection. The display will show a numerical value which corresponds with the factory setting.
- 3) Press the **+** or **-** buttons until the displayed number corresponds with the correct alignment of the cyan colour in the optical centre of the projector
- 4) Press the **enter** button to confirm your selection.

col2

- 1) Press the **+** or **-** buttons until **col2** (for colour 2 magenta alignment) is displayed.

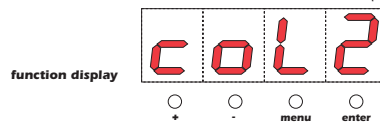

- 2) Press the **enter** button to confirm your selection. The display will show a numerical value which corresponds with the factory setting.
- 3) Press the **+** or **-** buttons until the displayed number corresponds with the correct alignment of the magenta colour in the optical centre of the projector
- 4) Press the **enter** button to confirm your selection.

col3

- 1) Press the **+** or **-** buttons until **col3** (for colour 3 yellow alignment) is displayed.

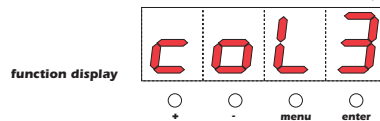

- 2) Press the **enter** button to confirm your selection. The display will show a numerical value which corresponds with the factory setting.
- 3) Press the **+** or **-** buttons until the displayed number corresponds with the correct alignment of the yellow colour in the optical centre of the projector
- 4) Press the **enter** button to confirm your selection.

FIAL

- 1) Press the **+** or **-** buttons until **FIAL** (for correction and effects filter wheel alignment) is displayed.

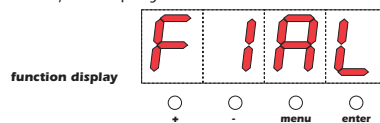

- 2) Press the **enter** button to confirm your selection. The display will show a numerical value which corresponds with the factory setting.
- 3) Press the **+** or **-** buttons until the displayed number corresponds with the correct alignment of the correction and effects wheel in the optical centre of the projector
- 4) Press the **enter** button to confirm your selection.

rcol

- 1) Press the **+** or **-** buttons until **rcol** (for colour wheel alignment) is displayed.

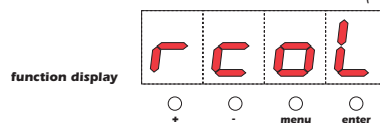

- 2) Press the **enter** button to confirm your selection. The display will show a numerical value which corresponds with the factory setting.
- 3) Press the **+** or **-** buttons until the displayed number corresponds with the correct alignment of the colour wheel in the optical centre of the projector
- 4) Press the **enter** button to confirm your selection.

diMM

- 1) Press the **+** or **-** buttons until **diMM** (for dimmer alignment).

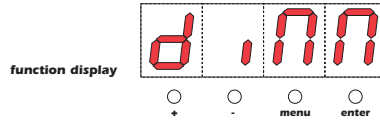

- 2) Press the **enter** button to confirm your selection. The display will show a numerical value which corresponds with the factory setting.
- 3) Press the **+** or **-** buttons until the displayed number corresponds with the correct closure of all the dimmers of the **CF 1200 Spots** in your installation.
- 4) Press the **enter** button to confirm your selection.

END

- 1) Press the **+** or **-** until **END** (for completion of the electronic alignment procedure) is displayed

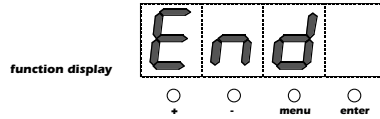

- 2) Press the **enter** button to confirm your selection. The display will revert to its normal operating mode and the internal memory will record all changes made.

N.B.: At the termination of the above electronic calibration procedure, if the **END** function is not performed, no memory changes will be effected. This allows the operator to abort any changes made, in case of operator error.

18. Spare parts

All the components of the **CF 1200 Spot** are available as replacement spares from your authorised **coemar** service centre.

Accurate description of the fixture, model number, and type will assist us in providing for your requirements, in an efficient and effective manner.