

coemar

Panorama Beam 1200 Touring bbi

**manuale
di istruzioni
instruction
manual**

**1[^] edizione, marzo 2000
1st edition, march 2000**

Panorama

Beam 1200 Touring **bbi**

numero di serie/serial number

data di acquisto/date of purchase

fornitore/retailer

indirizzo/address

cap/città/suburb

provincia/capital city

stato/state

tel./fax/

*Prendete nota, nello spazio apposito, dei dati relativi al modello e al rivenditore del vostro **Panorama Beam 1200 Touring bbi**: in caso di richiesta di informazioni, pezzi di ricambio, servizi di riparazione o altro ci permetteranno di assistervi con la massima rapidità e precisione.*

*Please note in the space provided above the relative service information of the model and the retailer from whom you purchased your **Panorama Beam 1200 Touring bbi**: This information will assist us in providing spare parts, repairs or in answering any technical enquiries with the utmost speed and accuracy.*

ATTENZIONE: la sicurezza dell'apparecchio è garantita solo con l'uso appropriato delle presenti istruzioni, pertanto è necessario conservarle.

WARNING: the security of the fixture is granted only if these instructions are strictly followed; therefore it is absolutely necessary to keep this manual.

Index

- 1. Packaging**
- 2. Transporting**
- 3. Important safety information**
- 4. Lamp: installation and replacement**
- 5. Operating frequency and voltage**
 - 5.1 Selecting the operating voltage and frequency of the lamp**
 - 5.2 Selecting the operating voltage of the transformer**
- 6. Installing the unit**
 - 6.1 Installing the unit in weather-protected areas**
 - 6.2 Installing the unit in exposed areas**
- 7. Mains connection**
- 8. Signal connection**
 - 8.1 For automated operation**
 - 8.2 for operation via DMX 512**
 - 8.3 Connecting multiple Panorama units in synch without DMX 512**
- 9. Powering up**
- 10. DMX addressing**
- 11. DMX 512 signal functions**
- 12. Automated operation**
- 13. Synchronising multiple Panorama units without DMX 512**
 - 13.1 Setting up a "master" unit**
 - 13.2 Setting up "slave" units**
- 14. Display panel functions**
- 15. Mechanical adjustments**
 - 15.1 Tilt adjustment**
- 16. Thermal protection**
- 17. Maintenance**
- 18. Electronic motor alignment**
- 19. Spare parts**
- 20. Authorised coemar service centres worldwide**

English

Congratulations on having purchased a **coemar** product. You have assured yourself of a fixture of the highest quality, both in componentry and in the technology used. We renew our invitation to you to complete the service information on the previous page, to expedite any request for service information or spares (in case of problems encountered either during, or subsequent to, installation). This information will assist in providing prompt and accurate advice from your **coemar** service centre.

1. Packaging

Following the instructions and procedures outlined in this manual will ensure the maximum efficiency of this product for years to come.

Open the packaging and ensure that no part of the equipment has suffered damage in transit. In case of damage to the equipment, contact your carrier immediately by telephone or fax, following this with formal notification in writing.

packing list

Ensure the packaging contains:

- 1 **Panorama Beam 1200 Touring bbi**
- 1 instruction manual

2. Transporting

The **Panorama Beam 1200 Touring bbi** should be transported in its original packaging or in a coemar approved flight case.

In order to manufacture a suitable flight case, we recommend the following simple procedure be followed, which will stop movement of the **Panorama Beam 1200 Touring bbi** during transportation.

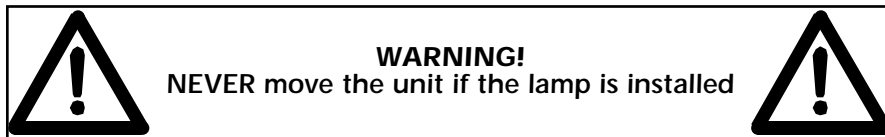

3. Important safety information

Fire prevention:

1. **Panorama Beam 1200 Touring bbi** utilises a Philips 1200 MSD; the use of any other lamp may damage the unit and will automatically void the warranty.
2. Never install the unit on flammable surfaces.
3. Minimum distance from flammable materials: 0,5 m.
4. Minimum distance from subject being illuminated: 2 m.
5. Replace any blown or damaged fuses only with those of identical values. Refer to the schematic diagram if there is any doubt.
6. Connect the projector to mains power via a thermal magnetic circuit breaker.

Prevention of electric shock:

1. High voltage is present in the internals of the unit. Isolate the projector from mains supply prior to performing any function which involves touching the internals of the unit, including lamp replacement.
2. For mains connection, adhere strictly to the guidelines outlined in section 6 of this manual
3. The level of technology inherent in the **Panorama Beam 1200 Touring bbi** requires the use of specialised personnel for all service applications; refer all work to your authorised **coemar** service centre.
4. A good earth connection is essential for proper functioning of the projector.
Never operate the unit without proper earth connection.

Protection against ultraviolet radiation:

1. Never turn on the lamp if the lense, the filters or the aluminium housing is damaged; they will only work effectively if they are in good condition.
Never look directly into the light beam when the lamp is on.

Safety:

1. The projector should always be installed with bolts, clamps, and other fixings which are suitably rated to support the weight of the unit.
2. Always use a secondary safety chain of a suitable rating to sustain the weight of the unit in case of the failure of the primary fixing point.
3. The external surface of the unit, at various points, may exceed 150°C. Never handle the unit until at least 8 minutes have elapsed since the lamp was turned off.
4. Always replace the lamp if any physical damage is evident.
5. Never install the fixture in an enclosed area lacking sufficient air flow; the ambient temperature should not exceed 35°C.
6. A hot lamp may explode. always wait for at least 8 minutes to elapse after the unit has been turned off prior to attempting to replace the lamp.
Always wear suitable hand protection when handling the lamp.

4. Lamp: installation and replacement

Panorama Beam 1200 Touring bbi utilises a Philips 1200 MSD with a G 22 base.

The lamp is available from your authorised **coemar sales agent**:

coemar cod.	105811
power	1200 w
luminous flux	92000 lm
colour temperature	6000° K
base	G 22
approximate lamp life	2000 ore



WARNING!
NEVER move the unit if the lamp is installed



Attention!

Remove mains power prior to opening up the unit..

The fixture's internal temperature can reach 250° C after 5 minutes, with a maximum peak of 350° C; ensure that the lamp is cold prior to attempting removal. The fixture should be allowed to stand and cool for 10 minutes prior to its removal.

MSD lamps are part of the mercury vapour family of discharge lamps and must be handled with great care. The lamp operates at high pressure, and the slight risk of explosion of the lamp exists if operated over its recommended life of 2000 hours.

installing the lamp

- 1) Using a Philips head screwdriver, remove the 8 screws (A) which affix the rear housing (B) to the body of the projector.
- 2) Using the attached handle remove the rear housing (B) of the projector, to which the lamp assembly is attached.

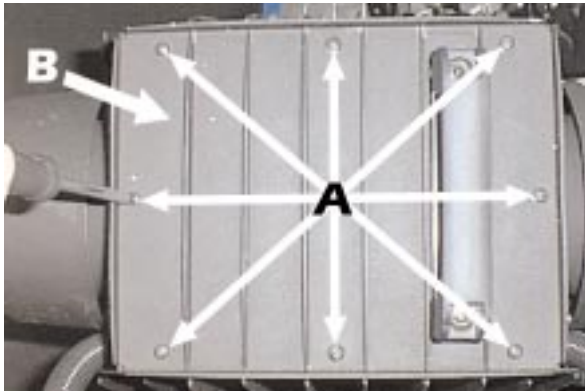

- 3) Using a Philips head screwdriver, remove the 3 screws (C) which affix the lamp assembly.

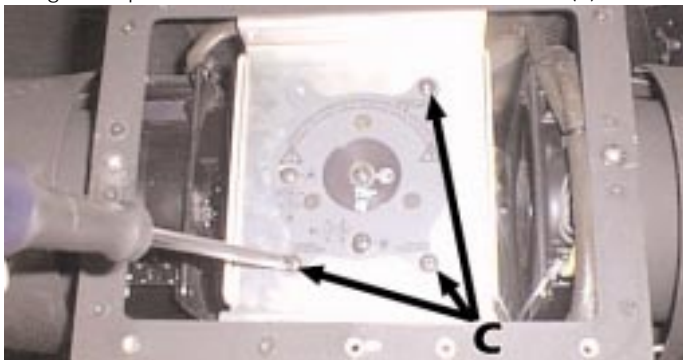

- 4) Remove the lamp assembly.



- 3) Locate the lampholder (D)

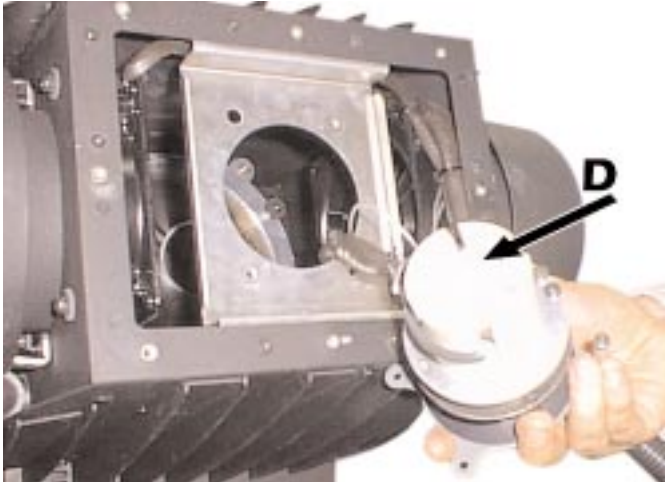

- 4) Insert the lamp. The G22 lampholder is symmetrical in its construction. The lamp used is manufactured from quartz glass and should be handled with care; always adhere to the instructions supplied in the lamp's packaging. Never touch the glass directly, use the tissue provided in the lamp's packaging. Insert the lamp into the lampholder. DO NOT USE UNDUE FORCE. In case of difficulty, re-read the instructions and repeat the procedure.



- 5) Replace the lamp assembly as it was originally and refasten the 3 screws (C) which were previously removed.

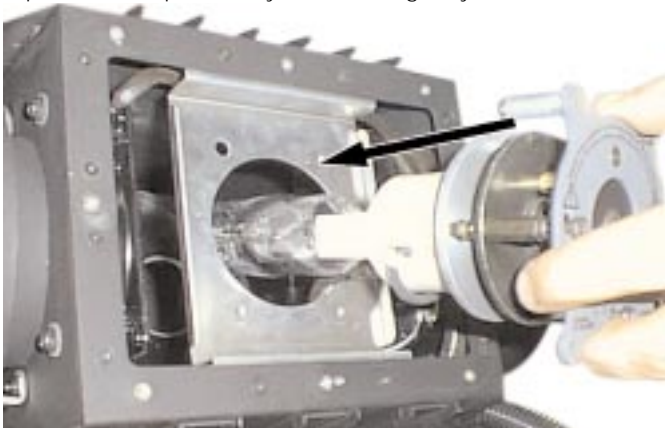

Attention: it is recommended that the lamp be re-aligned in the optical train of the projector to avoid overheating the dichroic filters and the internal components of the unit; refer to section 13 for further instructions.

5. Operating voltage and frequency

The projector may operate at 208, 230 or 240 V.at 50 or 60 Hz.

coemar factory presets (barring specific requests), a voltage of 230v and a frequency of 50Hz. The operating voltage and frequency of the unit is noted in the appropriate space on the label affixed to the base of the projector

factory set
main at:

- 208V
- 230V
- 240V

- 50Hz
- 60Hz

If the operating voltage and frequency of the projector do not match those available in the country in which the projector is being used, you may proceed to alter them as described in the paragraphs which follow.

The operating voltage and frequency must be selected on both the ballast (lamp supply) and the transformer (electronics supply).

An error in setting the correct operating voltage may compromise the proper operation of the unit and may cause serious damage.

5.1 Selecting the operating voltage and frequency for the lamp

This procedure will set the operating voltage or frequency for the lamp after the initial ignition of the lamp; the unit draws upon initial startup 13.8 Amps.

You must set the operating voltage or frequency suitable for the country in which the projector is being used.

1) Open up the base of the unit by removing the 4 hex screws which affix the cover located on the side of the base.



2) Remove the cover.



3) Locate the terminal strip marked with a sticker showing 208/230/240 V and 50 or 60Hz; the cables attached here at those which you will need to move.

4) Cable 15 determines operating voltage, move it to either of the 208, 230 or 240V terminals.

5) Cable 16 determines operating frequency, move it to either the 50 or 60Hz terminals.

6) After having moved the cables to the required position, replace the cover and refasten the screws.

To maintain the protection rating of the unit, the 4 screws need to be refastened gradually and firmly to ensure that they seal the unit but do not damage the seal.

5.2 Selecting the operating voltage of the transformer

This procedure will set the operating voltage for the projector's electronics.

You must set the operating voltage to suit the country in which the projector is being used.

1) Open up the base of the unit by removing the 4 hex screws which affix the cover located on the side of the base.

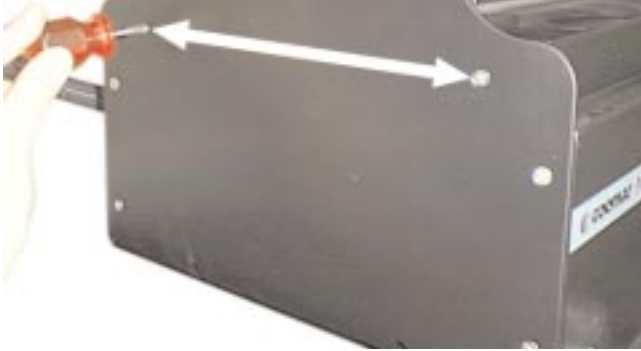

3) Remove the cover.



3) Locate the terminal strip.

4) The cable marked 15 determines the operating voltage of the transformer; move it to either of the 208, 230 or 240V terminals.

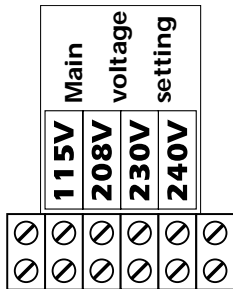

An error in selecting the correct operating voltage may adversely affect the operation of the unit or cause serious damage. Under no circumstances should cable 8 be moved.

5) After having moved the cables to the required position, replace the cover and refasten the screws.

6. Installing the unit

Panorama Beam 1200 Touring bbi, due to its high protection rating, may be mounted in any position either sheltered from or exposed to the elements.

6.1 Installing the unit in weather-protected areas



Panorama Beam 1200 Touring bbi may be situated in any mounting position when operated in sheltered areas.

So that it can be used in a variety of positions, the **Panorama Beam 1200 Touring bbi** is fitted with four rubber feet on its base which may, as you will note, be removed should you wish to permanently install the unit by affixing the base to a solid surface.

6.2 Installing the unit in exposed areas

Panorama Beam 1200 Touring bbi may be situated in several mounting positions when installed in an exposed area, thanks to its IP 44 protection rating. To ensure proper installation, however, there is a simple guideline to follow:

Attention!

As indicated in the diagram, the base of the unit must always be facing the ground.

Panorama Beam 1200 Touring bbi allows the beam of light to be tilted in the range of -60° to $+70^{\circ}$. without having to move any other component except the head of the fixture.

Mounting the unit incorrectly may cause damage to occur and incorrectly mounting the unit will immediately void the warranty.

If mounted in any other position other than with the base down, the projector will not be performing with its maximum protection rating, although, with adequate covering, it may operate in almost any position.

safety chain

The use of a safety chain (cod. 069) - fixed to the **Panorama Beam 1200 Touring bbi** and to the primary suspension point, is highly recommended to protect against accidental failure, however unlikely, of the primary suspension point.

If using an after-market safety chain not manufactured by **coemar**, ensure that it is of sufficient rating to hold the weight of the fixture.

risk of fire

Each fixture produces heat and must be installed in a well-ventilated position. The minimum recommended distance from flammable material is: 0.5m. Minimum distance from the object being illuminated is: 2 m.

7. Mains connection

preparing power cable

The mains cable provided is thermally resistant, complying to the most recent international standards. It meets or exceeds the VDE and IEC norms, IEC 331, IEC 332 3C, CEI 20 35.

NB: In case of cable replacement, similar cable with comparable thermal resistant qualities must be used exclusively (cable 3x1.5 \varnothing external 10 mm, rated 300/500V, tested to 2KV, operating temperature -40° +180°, **coemar** cod. CV5309).

mains connection

Panorama Beam 1200 Touring bbi can operate at voltages from 208V-230V-240V at 50 or 60Hz (operating voltage and frequency can be selected as described in section 5 of this manual).

Prior to connecting the unit to your mains supply, ensure that the model in your possession correctly matches the mains supply available to you.

For connection purposes, ensure your plug is of a suitable rating: 13,3 amps during startup and 9 amps during normal operation.

Locate the mains cable which exits the ballast and connect as shown below:

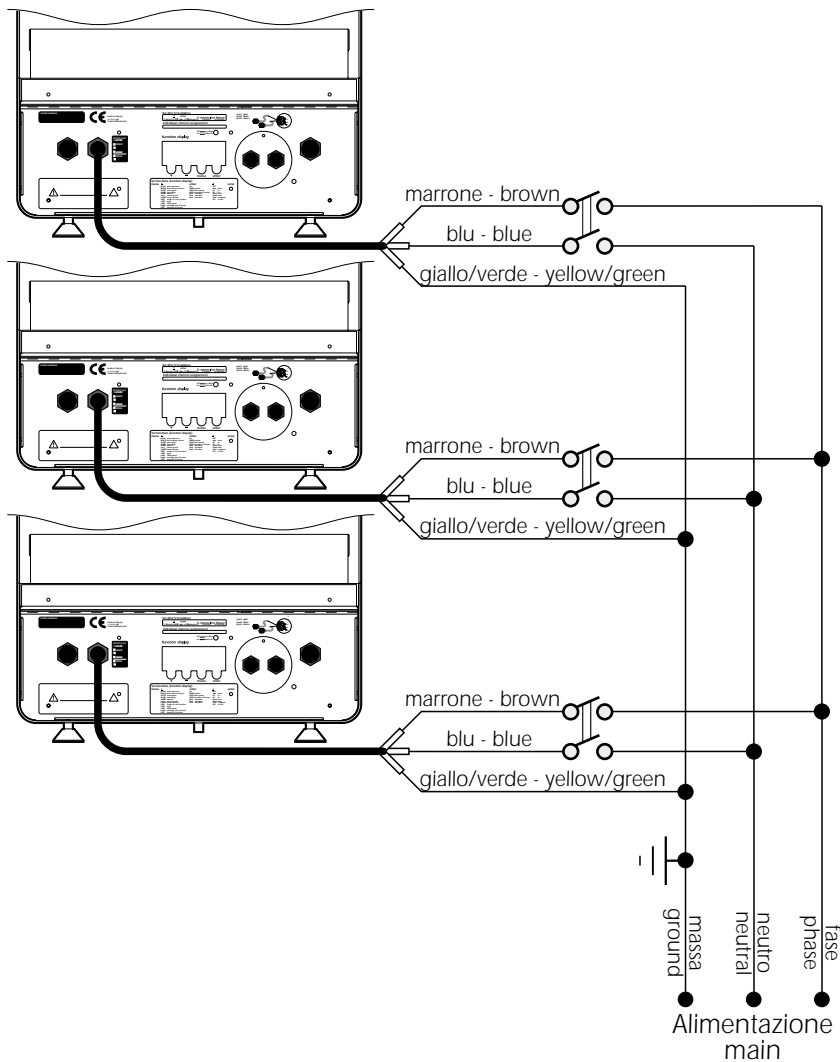

protection

The use of a thermal magnetic circuit breaker is recommended for each **Panorama Beam 1200 Touring bbi**.

A good earth connection is essential for the correct operation of the fixture. Strict adherence to regulatory norms is strongly recommended.

Panorama Beam 1200 Touring bbi must be earthed; never install the unit unless the yellow/green earth cable is securely connected.

8. Signal connection

Panorama Beam 1200 Touring bbi may operate in 3 different modes:

8.1 Automated operation

8.2 Using DMX 512 signal

8.3 Synchronising Panoramas without DMX 512 signal.

Depending upon the operating mode you wish to use you should connect units as described below:

8.1 Automated operation

Panorama Beam 1200 Touring bbi may operate in stand alone mode in the absence of control signal, using pre-programmed colour changing sequence which can be activated by the multi-function panel on the unit.
No incoming signal to the XLR3 sockets should be connected.

We recommend that the XLR 3 sockets be isolated by using suitably sheathed weather-proof dummy plugs.

This ensures that the weather rating of the **Panorama is maintained**; **coemar** supplies two XLR 3, IP 67 rated plugs for this purpose.

8.2 Using DMX 512 signal

Control signal is digital, and is transmitted via two pair screened $\varnothing 0.5\text{mm}$ cable.

Connection is serial, utilising the XLR 3 sockets located on the base of the **Panorama Beam 1200 Touring bbi**.

We recommend that the last link in the DMX chain be isolated by using suitably sheathed weather-proof dummy plugs.

This ensures that the weather rating of the **Panorama is maintained**; **coemar** supplies two XLR 3, IP 67 rated plugs for this purpose.

A connection using the 3 Pin XLR 3

Connection is to international standards:

pin 1= gnd
pin 2= data -
pin 3= data +

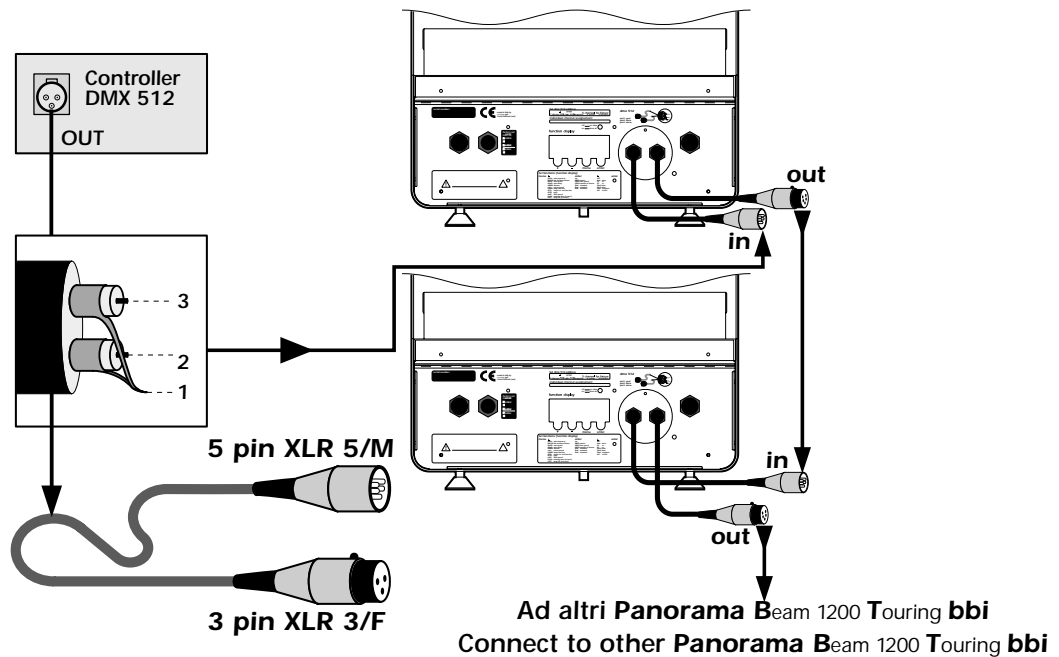

Ensure that all data conductors are isolated from one another and the metal housing of the connector.

Note: the housing of the XLR 3 must be isolated.

Should your **DMX 512** controller output via an XLR 5 socket, the polarity of pins 1, 2 and 3 must be maintained and pins 4 and 5 should remain unconnected.

Connection is to international standards:

- pin 1= gnd
- pin 2= data -
- pin 3= data +
- pin 4= optional - not connected
- pin 5= optional + not connected

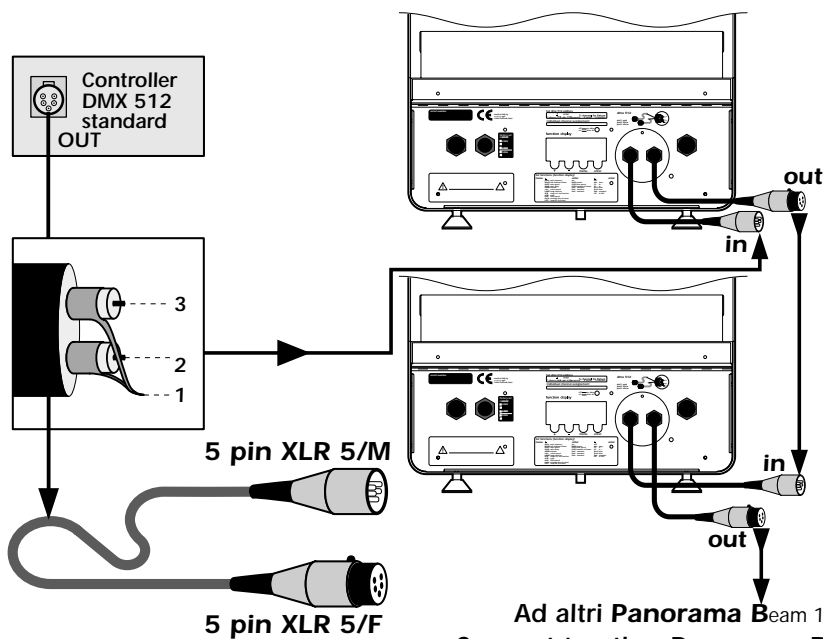

8.3 Synchronising Panoramas without DMX 512 signal

Multiple **Panorama Beam 1200 Touring bbi** units may be interconnected in the absence of DMX 512 signal, operating simply via the inbuilt programs within the **Panorama unit**.

All the **Panorama Beam 1200 Touring bbi's thus connected will operate simultaneously** with one unit acting as MASTER and all subsequent units as a SLAVE.

Determine which of the **Panorama Beam 1200 Touring bbi** will act as master, usually by the criterion of ease of access: Using XLR 3 connectors, daisy-chain the units with the master connected to the first slave, and then slave to slave, up to a maximum of 10 units in total.

Should you need to connect more than 10 units we recommend that you use a suitable dmx splitter box to achieve this. These units are usually opto-isolated and may amplify and repeat the signal as required.

Attention! We recommend that any unused sockets be terminated to preserve the weather protection rating of the units. We recommend that these links in the DMX chain be isolated by using suitably sheathed weather-proof dummy plugs. This ensures that the weather rating of the **Panorama is maintained**; coemar supplies two XLR 3, IP 67 rated plugs for this purpose.

Connection is to international standards:

- pin 1= gnd
- pin 2= data -
- pin 3= data +

Ensure that all data conductors are isolated from one another and the metal housing of the connector.

Note: the housing of the cannon XLR 3 must be isolated.

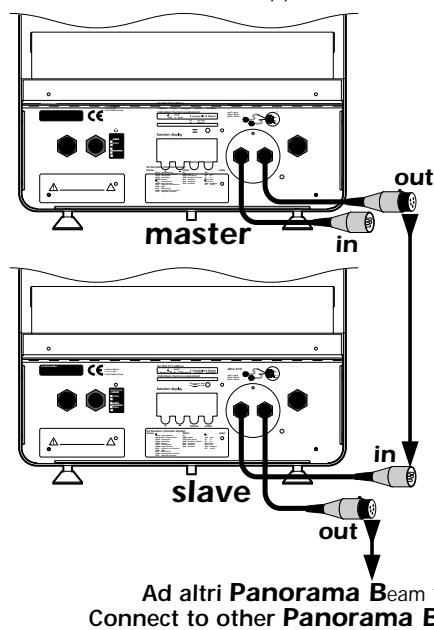

9. Powering up

After having followed the preceding steps, turn on the DMX 512 controller which will be used to control the **Panorama Beam 1200 Touring bbi** . Following this, turn on the power to the unit, and turn on the unit's power switch. **The fixture will perform a reset function on its internal motors. This will last some few seconds, after which it will be subject to the external signal from the controller.**

DMX led

The DMX **led** will be static on to indicate that **DMX 512** signal is being correctly received.

Set dmx 512 address

± enter 5 channel for fixture
A001 to A506

Individual channel assignement

1 dimmer 2 cyan 3 magenta 4 yellow 5 function

off — no dmx
on — dmx ok 

function display

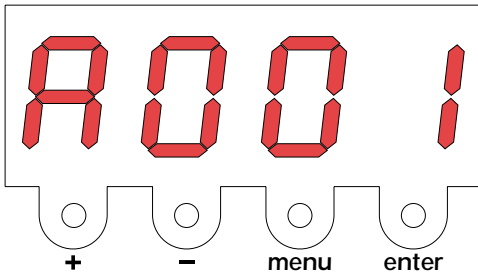

If the led is off, the projector is not receiving signal. check the cabling and the functioning of the controller.

10. DMX addressing

Each Panorama Beam 1200 Touring **bbi** utilises **5 channels of DMX 512 signal for complete control.**

To ensure that each unit accesses the correct signal, it is necessary to correctly address each fixture. Any number between 1 and 506 can be generated via the multifunction panel of the **Panorama Beam 1200 Touring bbi**.

This procedure must be carried out on every **Panorama Beam 1200 Touring bbi** being used.

When powered up initially, each projector will show **A001** which indicates **DMX address 1**; a projector thus addressed will respond to commands on channels **1 to 5** from the **DMX 512 controller**. A second projector should be addressed as 6 a third as **11** and so on until the final **unit has been addressed**.

Altering DMX addresses

- 1) Press the + or - button until the display shows the **DMX** required, the characters in the display panel will flash to indicate that the selection is not stored in memory.

function display

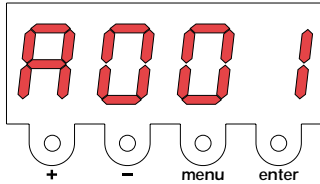

- 2) Press the enter button to confirm your selection; the display will stop flashing and the projector will now respond to the new DMX address.
- 3) To better understand the function of each channel, we refer you to section 11 "DMX 512 signal functions".

Important Note: Keeping the + or - button pressed will cause the display to alter at increased speed, allowing a faster selection to be effected.

11. DMX 512 signal functions

Panorama Beam 1200 Touring bbi may be operated using DMX 512 signal, connection is described in section "8.2 Using DMX 512 signal".

If you have followed all instructions correctly to this point, the 5 channels of your **DMX 512** controller will have control of all the functions of the **Panorama Beam 1200 Touring bbi** as shown in the following table:

channel	function	type of control	effect	decimal
1	dimmer	step	closed	0-7
		proportional	from close to open	8-255
2	cyan	proportional	proportional cyan control from white to cyan	0-255
3	magenta	proportional	proportional magenta control from white to magenta	0-255
4	Yellow	proportional	proportional yellow control from white to yellow	0-255
5	function	step	lamp off	0-114
			motor reset	115-140
			lamp on	141-255
Back panel can modify function channel (inhibit lamp off)				
5	function	step	lamp on	0-114
			motor reset	115-140
			lamp on	141-255
note 1: 2 or 4 numbers close to the end limit levels cannot be used as unstable levels				
note 2: function channel has a delay time of 6 second to prevent accidental activation.				
note 3 :on/off lamp mode is not affected unless an opposite value is received				

To remotely control lamp ignition, you must position channel 5 at a level between 141 and 255.

12. Automated operation

The **Panorama Beam 1200 Touring bbi** may operate without external signal, executing two pre-programmed colour changes as discussed in section "8.1 Automated operation".

To engage the automated programs, after having turned on power to the unit, use the four buttons on the multi-function display to select from the options available:

- 1- Activate the automated colour changing programs (**AUTO ON**)

A001 — menu — + o — **AUSP** velocità di esecuzione del programma di cambio colore
 Regolazione del tempo di permanenza di un colore dei programmi 1 o 2 nel fascio

enter — + o — da **-000** — enter
 |
 + o — a **-661** — enter
 |
 velocità minima
 velocità massima

- 2- Select from the two programs available; the 1° program (**PRO1**) utilises a 32 colour sequence, the 2° program (**PRO2**) utilises 55.

A001 — menu — + o — **PROG** programma
 Selezione del programma in esecuzione automatica (2 possibili selezioni)

enter — + o — **PRO1** — enter
 |
 + o — **PRO2** — enter
 |
 programma n° 1
 programma n° 2

- 3- Adjust the hold time for each colour in the sequence, if you wish to alter from the 0 set as the **coemar** default.

A001 — menu — + o — **AUSP** velocità di esecuzione del programma di cambio colore
 Regolazione del tempo di permanenza di un colore dei programmi 1 o 2 nel fascio di luce.

enter — + o — da **-000** — enter
 |
 + o — a **-661** — enter
 |
 velocità minima
 velocità massima

- 4- Adjust the fade time between the colours, if you wish to alter from the **STRD** set as **coemar** default.

A001 — menu — + o — **COLR** velocità del cambiacolori
 Velocità di intervento del sistema cambiacolori al variare del segnale DMX (selezione tra standard e lenta -slow-).

enter — + o — **STRD** — enter
 |
 + o — **SLOU** — enter
 |
 velocità standard
 velocità lenta

Note: Projectors in automated mode will have the lamp turn on immediately and will be unable to have control of their dimmer modified.

13. Synchronising several Panoramas without using DMX 512 signal

Multiple **Panorama Beam 1200 Touring bbi** units may be used in synchronised mode to use the automated preset programs without the need for an external control signal by completing the following procedure.

Panorama units connected together will operate in a master/slave mode.

The units may be synchronised to operated simultaneously or may be operated so that the "slave" units, as selected, operate with independent time delays:

To set up automated mode, complete the procedure described in section "**8.3 Synchronising Panoramas without using DMX 512 signal**", then set up the automated function with the four multi-function display buttons.

13.1 Setting up a "master"

Only one projector may be set up as "**Master**" the initial projector in the dmx daisy chain and the only one with its "**DMX IN**" socket empty.

- 1- Set up a unit as **master (MAST)**.

A001 menu +0- **M.A.S.L** master o slave enter +0- **MAST** proiettore master enter

Permette di codificare i proiettori come **master** (generatore) o **slave** (ricevitore).

- 2- Activate the automated program (**AUTO ON**)

A001 menu +0- **A.U.S.P** velocità di esecuzione del programma di cambio colore enter +0- da **-000** enter
Regolazione del tempo di permanenza di un colore dei programmi 1 o 2 nel fascio
|
velocità minima
 +0- a **-661** enter
velocità massima

- 3- Select from the two programs available; the 1° program (**PRO1**) utilises a 32 colour sequence, the 2° program (**PRO2**) utilises 55.

A001 menu +0- **P.R.O.G** programma enter +0- **PRO1** enter
Selezione del programma in esecuzione automatica (2 possibili selezioni)
|
programma n° 1
 +0- **PRO2** enter
programma n° 2

- 4- Adjust the hold time for each colour in the sequence, if you wish to alter from the 0 set as the **coemar** default.

A001 menu +0- **A.U.S.P** velocità di esecuzione del programma di cambio colore enter +0- da **-000** enter
Regolazione del tempo di permanenza di un colore dei programmi 1 o 2 nel fascio di luce.
|
velocità minima
 +0- a **-661** enter
velocità massima

- 5- Adjust the fade time between the colours, if you wish to alter from the **STRD** set as **coemar** default.

A001 menu +0- **C.O.L.R** velocità del cambiacolori enter +0- **STRD** enter
Velocità di intervento del sistema cambiacolori al variare del segnale DMX (selezione tra standard e lenta -slow-).
|
velocità standard
 +0- **S.L.O.U** enter
velocità lenta

Note: Projectors in automated mode will have the lamp turn on immediately and will be unable to have control of their dimmer modified.

13.2 Setting up "slave" units

All units being operated from the master unit must be set to "Slave" mode.

They must be connected correctly in the dmx daisy chain, see section **8.3 Synchronising Panoramas without DMX 512 signal**

Projectors set up as "Slave" are recognisable as they are the only ones with both dmx in and out sockets connecte (with the exception of the last in the series which has only its "DMX IN" socket utilised).

The procedure for setting up a unit as a "Slave" is as follows:

- 1- Set up the unit as "Slave" (SLAV).

A001 — menu — +0— **MASL** master o slave — enter — +0— **SLAV** proiettore slave — enter — **-SL-**
 Permette di codificare i proiettori come **master** (generatore) o **slave** (ricevitore).

When the display show **-SL-** you have correctly set the projector as a **Slave** which will follow the signal sent to it by the master unit.

The display options now offered by the **Panorama** are much simplified to those of the master.

- 2- At this point, you may alter the delay time of the individual slave unit to that of its master.

-SL- — menu — +0— **AUDL** sincronizzazione ritardata — enter — +0— da **0000** — enter —
 Impostazione del tempo di ritardo sull'esecuzione della sincronizzazione del programma di cambio colore impostato sul proiettore master. Funzione visibile e attivabile solo sul proiettore **-SL- slave**.
 nessun ritardo
 a **0055**
 massimo ritardo

The delay may be altered from 0 to 55 and relates to the point at which the slave will commence its colour change sequence with respect to that being generated by the master.

For example:

Synchronising two projectors with **AUDL**= 20.

When the Master reaches the 20th colour in its colour change sequence, the slaves set to **AUDL 20** will begin with the first colour.

The synchronising continues until the projectors are turned off.



























The **AUDL** function thereby allows different areas of your lighting subject to be in lit in diverse colors whilst maintaining the sequence amongst them (as set by the master).

14. Display panel functions

























On display panel of **Panorama Cyc 1800** are shown all the functions available; it is possible to change some of those parameters and to add some functions.

Changing the setting made by **coemar** can vary the functions of the device that will not respond to the DMX 512 mixer used to control it. Please carefully follow the instructions, before applying any variations or selections.

NOTE: the symbol  shows which key has to be pushed to obtain the function desired.

A001	 menu	 +0- D IMM dimmer speed	 enter	 +0- STRD	 enter
		Mechanical dimmer operating time speed on DMX signal variation. (selection between standard and slow)		standard speed	
		 +0- COLR colour changer speed	 enter	 +0- SLOU	 enter
		Colour changing system operating time speed on DMX signal variation. (selection between standard and slow)		low speed	
		 +0- LAMP lamp function	 enter	 +0- STRD	 enter
		Lamp on/off control inhibition by DMX signal (channel 5)		standard speed	
		 +0- TEST test function	 enter	 +0- SLOU	 enter
		Device operation test without DMX signal		low speed	
 +0- RESE reset	 enter	 +0- STRD	 enter		
Reset function		ignition by DMX 512			
 +0- RATE DMX speed	 enter	 +0- ON	 enter		
DMX signal reception speed		lamp always on			
 +0- HOUR working time (in hour)	 enter	 +0- TO1	 enter		
Visualization of projector's working time (time covered by mains supply)		dimmer test			
 +0- LIFE lamp life (in hour)	 enter	 +0- TO4	 enter		
Visualization of lamp life (time covered by mains supply from last reset operation)		yellow colour test			
		 +0- ---	 enter		
		reset activation			
		 +0- 24.S0	 enter		
		numeric value			
		 +0- 0280	 enter		
		numeric value shown in hours			
		 +0- 0340	 enter		
		numeric value shown in hours			

Functions described on paragraph 12 and 13.

A001	 menu	 +0- AUTO automatic movement	 enter	 +0- OFF	 enter
		to activate colour changing effects without using an external control signal		to disable the function	
		 +0- MASL master or slave	 enter	 +0- ON	 enter
		to assign a code to the projectors as master (generator) or slave (receiver).		to enable the function	
		 +0- AUSP colour changing program speed execution	 enter	 +0- MAST	 enter
		Stay time and adjustment of one colour in the beam (program 1 or 2).		master	
 +0- PROG program	 enter	 +0- SLAV	 enter		
Program selection in auto mode (2 selections available)		slave	 -SL-		
			confirm slave		
 +0- AUDL delayed synchronization	 enter	 +0- from 0000	 enter		
To set the delay time on synchronization of colour changing program set on master device. This function can be seen and activated only on slave unit -SL- slave .		no delay			
		 +0- to 0055	 enter		
		maximum delay			

15. Mechanical adjustments

After having powered up the projector and set up either DMX 512 or automated control of the functions of the **Panorama Beam 1200 Touring bbi**, you may wish to perform the following mechanical adjustments to optimise the output of the unit in your installation.

15.1 Tilt adjustments

Loosen the knobs at the sides of the unit which allow adjustment (+70° -60°) of the tilt position of the beamspread.



After having set up the position as required, remember to tighten the knobs once again to avoid movement.

16. Thermal protection

A thermal sensor located in the body of the **Panorama Beam 1200 Touring bbi** protects the unit from overheating. Should the unit overheat due to it being poorly ventilated or the ambient temperature be too high or a cooling fan fail, the thermal sensor will cause voltage to be removed from the lamp circuit.

17. Maintenance

Whilst every possible precaution has been taken to ensure the trouble-free operation of your **Panorama Beam 1200 Touring bbi**, the following periodic maintenance is highly recommended. Make sure that mains power is disconnected prior to performing any maintenance.

Attention

Disconnect mains power prior to opening the inspection lid

periodic cleaning internal access

To gain access to the internals of the projector, remove the rear cover by undoing the 12 screws.

reflector

Clean the reflector using a soft cotton cloth, dampened

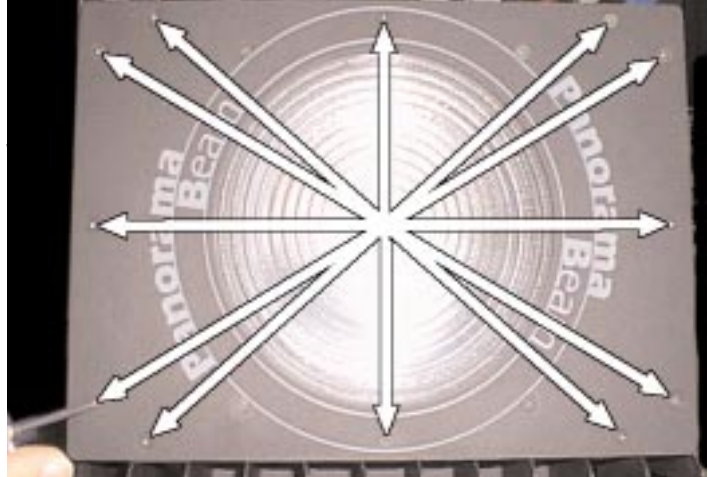
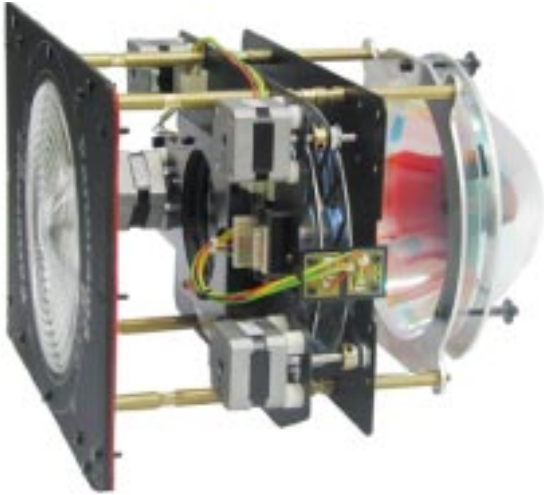

periodic maintenance Lamp

The lamp should be replaced if there is any observable damage or deformation due to heat. This will avoid the danger of the lamp exploding; you may gain access to the lamp as described in section 4.

Fans and air passages



The fans and air passages must be cleaned approximately every 6 weeks; the period for this periodic cleaning will depend, of course, upon the conditions in which the projector is operating. Suitable instruments for performing this type of maintenance are a brush and a common vacuum cleaner or an air compressor.

filters and air inlets

the filters and air inlets must be cleaned regularly to ensure the unit operates correctly. This should be undertaken at least every 4 weeks, the period for this periodic cleaning will depend, of course, upon the conditions in which the projector is operating.

To gain access to the filter, remove the two screws which hold it in place, located at the rear of the unit. Suitable instruments for performing this type of maintenance are a brush and a common vacuum cleaner or an air compressor. Should this not suffice, the filter itself may be immersed in a cleaning detergent.



mechanicals

Periodically check all mechanical devices for wear and tear; gears, guides, belts, etc., replacing them if necessary. Ensure the screws affixing the barndoors are firmly tightened.

electrical components

Check all electrical components for correct earthing and proper attachment of all connectors, refastening if necessary.

dichroic filters

To properly clean the dichroic filters it is necessary to remove the screws which affix the rear of the projector head. The rear of the projector head, together with its seal, will come away.

Move each dichroic filter manually to allow access to it and clean with a suitable glass cleaning detergent.

Attention! Once you have completed the cleaning procedure, make sure that the the seal is correctly replaced when replacing the rear of the projector head.

Should you fail to do this, the protection rating of the unit will be compromised, and the internal of the unit may be subject to the adverse effects of the weather. This may result in damage to these components.

fuse replacement

To replace the fuse it is necessary to remove the two housing plates and open the terminal cover box as described in the section entitled "Selecting the operating voltage of the transformer" then replacing the fuse as required. Note that the fuse must be replace with one of similar value.

18. Electronic motor alignment

RESERVED FOR INSTALLERS ONLY

The display panel on the **Panorama Beam 1200 Touring bbi** allows for the electronic calibration of the units motors; this procedure is undertaken by **coemar** at predelivery; it may be useful to perform this procedure in the case of internal components being replaced.

Altering the factory settings may radically alter the functioning of the projector. Carefully read all of the following prior to attempting any changes.

electronic calibration

Important Note: electronic calibration is only possible if the projector is connected to a **DMX 512** source.

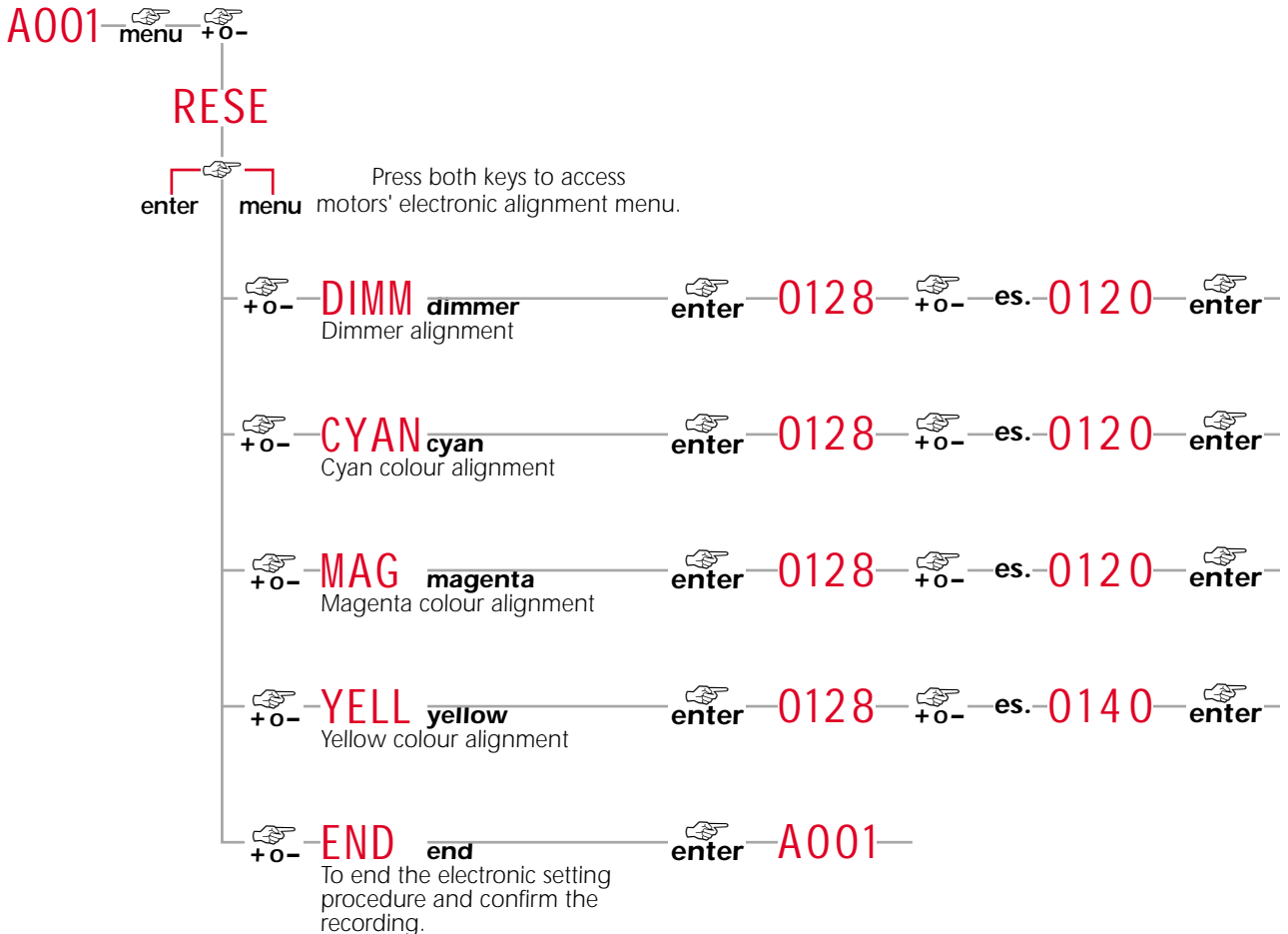

Important Note: At the termination of the above electronic calibration procedure, if the END function is not performed, no memory changes will be effected. This allows the operator to abort any changes made, in case of operator error.

19. Spare parts

All the components of the **Panorama Beam 1200** Touring bbi are available as replacement spares from your authorised **coemar** sales agent.

Accurate description of the fixture, model number, and type will assist us in providing for your requirements in an efficient and effective manner.



coemar si riserva il diritto di apportare modifiche senza preavviso.
coemar reserves the right to effect modifications without notification

manuale istruzioni
instruction manual

Panorama Beam 1200 Touring bbi

1[^] edizione aprile 2000
1st edition april 2000