

coemar

Panorama Cyc 1800 Touring

**manuale
di istruzioni
instruction
manual**

**1^a edizione, ottobre 1999
1st edition, october 1999**

Panorama

Cyc 1800 Touring

numero di serie/serial number _____

data di acquisto/date of purchase _____

fornitore/retailer _____

indirizzo/address _____

cap/città/suburb _____

provincia/capital city _____

stato/state _____

tel./fax/ _____

*Prendete nota, nello spazio apposito, dei dati relativi al modello e al rivenditore del vostro **Panorama Cyc 1800 Touring**: in caso di richiesta di informazioni, pezzi di ricambio, servizi di riparazione o altro ci permetteranno di assistervi con la massima rapidità e precisione.*

*Please note in the space provided above the relative service information of the model and the retailer from whom you purchased your **Panorama Cyc 1800 Touring**: This information will assist us in providing spare parts, repairs or in answering any technical enquiries with the utmost speed and accuracy.*

ATTENZIONE: la sicurezza dell'apparecchio è garantita solo con l'uso appropriato delle presenti istruzioni, pertanto è necessario conservarle.

WARNING: the security of the fixture is granted only if these instructions are strictly followed; therefore it is absolutely necessary to keep this manual.

Index

- 1. Packaging**
- 2. Transporting**
- 3. Important safety information**
- 4. Lamp: installation and replacement**
- 5. Operating frequency and voltage**
 - 5.1 Selecting the operating voltage and frequency of the lamp**
 - 5.2 Selecting the operating voltage of the transformer**
- 6. Mounting the unit**
 - 6.1 Installing the unit in weather-protected areas**
 - 6.2 Installing the unit in exposed areas**
 - 6.3 Mounting the ballast**
- 7. Mains connection**
- 8. Signal connection**
 - 8.1 Automated operation**
 - 8.2 Using DMX 512 signal**
 - 8.3 Synchronising Panoramas without DMX 512 signal**
- 9. Powering up**
- 10. DMX addressing**
- 11. DMX 512 signal**
- 12. Automated operation**
- 13. Synchronising several Panoramas without DMX 512 signal**
 - 13.1 Setting up a “master” unit**
 - 13.2 Setting up “slave” units**
- 14. Display panel functions**
- 15. Mechanical adjustments**
 - 15.1 Tilt adjustment**
 - 15.2 Barndoor adjustment**
 - 15.3 Altering beam angles by inserting diffusion filters**
- 16. Thermal protection**
- 17. Maintenance**
- 18. Electronic motor alignment**
- 19. Spare parts**

English

Congratulations on having purchased a **coemar** product. You have assured yourself of a fixture of the highest quality, both in componentry and in the technology used. We renew our invitation to you to complete the service information on the previous page, to expedite any request for service information or spares (in case of problems encountered either during, or subsequent to, installation). This information will assist in providing prompt and accurate advice from your **coemar** service centre.

1. Packaging

Following the instructions and procedures outlined in this manual will ensure the maximum efficiency of this product for years to come.

Open the packaging and ensure that no part of the equipment has suffered damage in transit. In case of damage to the equipment, contact your carrier immediately by telephone or fax, following this with formal notification in writing.

packing list

Ensure the packaging contains:

- 1 **Panorama Cyc 1800 Touring**
- 1 Ballast
- 1 Instructions manual
- 8 trapezoidal adjusters and associated assembly nuts & bolts

2. Transportation

The **Panorama Cyc 1800 Touring** should be transported in its original packaging or in a coemar approved flight case. In order to manufacture a suitable flight case, we recommend the following simple procedure be followed, which will stop movement of the **Panorama Cyc 1800 Touring** during transportation.

3. Important safety information

Fire prevention:

1. **Panorama Cyc 1800 Touring** utilises a Philips MSI 1800; the use of any other lamp may damage the unit and will automatically void the warranty.
2. Never install the unit on flammable surfaces.
3. Minimum distance from flammable materials: 0,5 m.
4. Minimum distance from subject being illuminated: 2 m.
5. Replace any blown or damaged fuses only with those of identical values. Refer to the schematic diagram if there is any doubt.
6. Connect the projector to mains power via a thermal magnetic circuit breaker.

Prevention of electric shock:

1. High voltage is present in the internals of the unit. Isolate the projector from mains supply prior to performing any function which involves touching the internals of the unit, including lamp replacement.
2. For mains connection, adhere strictly to the guidelines outlined in section 6 of this manual
3. The level of technology inherent in the **Panorama Cyc 1800 Touring** requires the use of specialised personnel for all service applications; refer all work to your authorised **coemar** service centre.
4. A good earth connection is essential for proper functioning of the projector. Never operate the unit without proper earth connection.

Protection against ultraviolet radiation:

1. Never turn on the lamp if the lense, the filters or the aluminium housing is damaged; they will only work effectively if they are in good condition.
Never look directly into the light beam when the lamp is on.

Safety:

1. The projector should always be installed with bolts, clamps, and other fixings which are suitably rated to support the weight of the unit.
2. Always use a secondary safety chaign of a suitable rating to sustain the weight of the unit in case of the failure of the primary fixing point.
3. The external surface of the unit, at various points, may exceed 150°C. Never handle the unit until at least 8 minutes have elapsed since the lamp was turned off.
4. Always replace the lamp if any physical damage is evident.
5. Never install the fixture in an enclosed area lacking sufficient air flow; the ambient temperature should not exceed 35°C.
6. A hot lamp may explode. always wait for at least 8 minutes to elapse after the unit has been turned off prior to attempting to replace the lamp.
Always wear suitable hand protection when handling the lamp.

4. Lamp: Installation and replacement

Panorama Cyc 1800 Touring utilises a Philips 1800 MSI 1800W lamp with a SFc 15,5 lampbase.

The lamp is available from your authorised **coemar sales agent:**

coemar cod.	105808
power	1800 w
luminous flux	155000 lm
colour temperature	5600° K
base	SFc 15,5
approximate lamp life	3000 hours

Attention!

Remove mains power prior to opening up the unit.

The fixture's internal temperature can reach 250° C after 5 minutes, with a maximum peak of 350° C; ensure that the lamp is cold prior to attempting removal. The fixture should be allowed to stand and cool for 10 minutes prior to its removal.

MSI lamps are part of the mercury vapour family of discharge lamps and must be handled with great care. The lamp operates at high pressure, and the slight risk of explosion of the lamp exists if operated over its recommended life of 3000 hours. We recommend, therefore, that the lamp is replaced within the manufacturer's specified lamp life.

mounting the lamp

- 1) Using a cross head screwdriver, remove the 14 screws (A) which affix the rear housing (B) to the body of the projector.

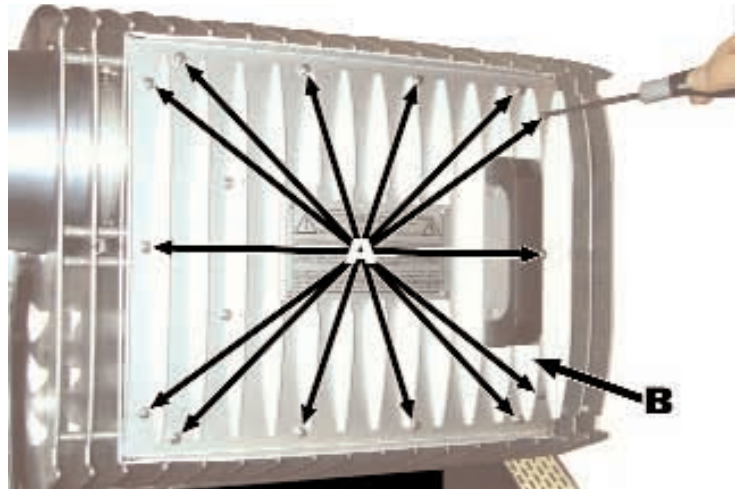

- 2) Using the attached handle remove the rear housing (B) of the projector, to which the lamp assembly is attached.

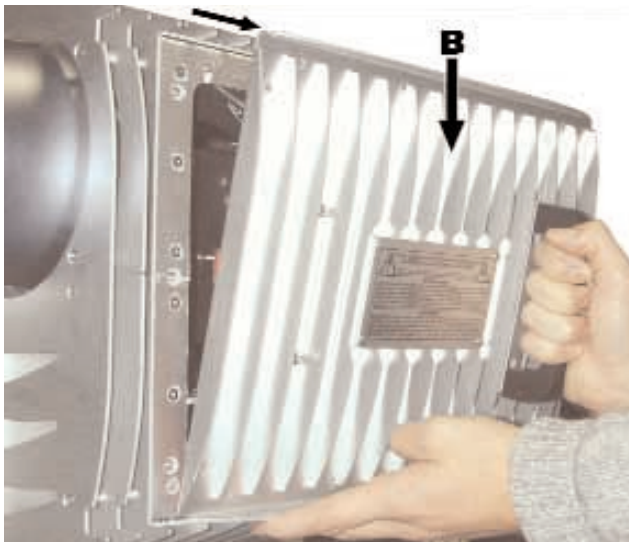

- 3) Remove the lateral reflectors (C) by removing the 4 screws (D).

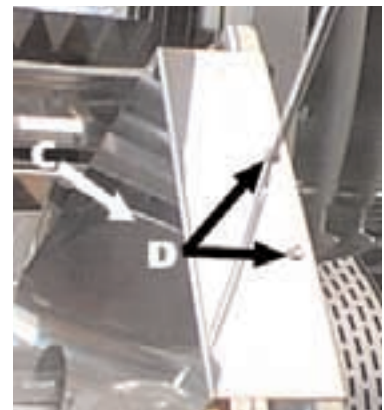

- 4) Locate the SFC 15,5 lampholder.
- 5) The SFC 15,5 lampholder is symmetrical in its construction. The lamp used is manufactured from quartz glass and should be handled with care; always adhere to the instructions supplied in the lamp's packaging. Never touch the glass directly, use the tissue provided in the lamp's packaging.

Loosen the two side thumbscrews on the lamp. Insert the lamp into the lampholder. **DO NOT USE UNDUE FORCE.** In case of difficulty, re-read the instructions and repeat the procedure.

To ensure a uniform beam spread, ensure that the lamp is installed with the pinch in the bulb facing the top of the unit.

Press the lamp firmly into the lampholder to ensure it is seated correctly. This will ensure that the lamp is seated correctly in the optical system of the unit. If this is not done, the beamspread may not be uniform.



- 6) Tighten the thumbscrews at each end of the lamp.
- 7) Reposition the two lateral reflectors on the lamp assembly.

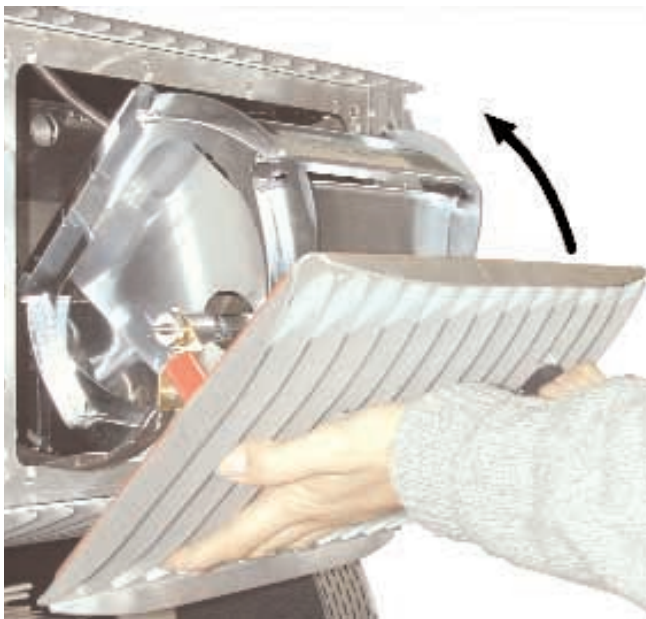

- 8) Replace the rear housing.
- 9) Retighten the 14 screws (A).

5. Operating voltage and frequency

The projector may operate at 208, 230 or 240 V.at 50 or 60 Hz.

coemar factory presets (barring specific requests), a voltage of 240v and a frequency of 50Hz. The operating voltage and frequency of the unit is noted in the appropriate space on the lable affixed to the base of the projector (electronics voltage) and internally on the ballast (lamp voltage and frequency).

factory set main at:

115V 208V 230V 240V

If the operating voltage or frequency does not match that of the country in which you are operating the unit, proceed as follows.

The operating voltage and frequency must be set both on the ballast (lamp voltage) and the transformer (electronics voltage).

An error in setting the correct operating voltage or frequency **may cause serious damage to the unit.**

5.1 Selecting the operating voltage and frequency for the lamp

This procedure will set the operating voltage or frequency for the lamp after the initial ignition of the lamp; the unit draws upon initial startup 17,3 Amps.

You must set the operating voltage or frequency suitable for the country in which the projector is being used.



- 1) Open up the ballast by removing the 4 hex screws with an M 5 allen key
- 2) Locate the terminal strip marked with a sticker showing 208/230/240 V and 50 or 60Hz; the cables attached here at those which you will need to move.
- 3) Cable 19 determines operating voltage, move it to either of the 208, 230 or 240V terminals.
- 4) Cable 1 determines operating frequency, move it to either the 50 or 60Hz terminals.
- 5) After having moved the cables to the required position, re-close the ballast as per its original condition.

To maintain the protection rating of the unit, the 4 screws need to be refastened gradually and firmly to ensure that they seal the unit but do not damage the seal.

5.2 Selecting the operating voltage of the trasformer

This procedure will set the operating voltage for the projectors electronics.

You must set the operating voltage to suit the country in which the projector is being used.



- 1) Using a cross head screwdriver, remove the 12 screws which affix the two housings of the base, these screws are located at the front, rear, and sides of the projector.
- 2) Using a suitable screwdriver, remove the 4 screws which seal the terminal cover



- 3) Locate the multipole terminal strip and proceed as follows.
- 4) Cable number 15 determines operating voltage; connect it to either the 208V, 230V or 240V terminal.

An error in setting the correct operating voltage **may cause serious damage to the unit. Do not move the cable numbered 8.**

- 5) After having selected the correct voltage, replace the internal terminal cover as well as the external housing of the unit.

6. Mounting the unit

Panorama Cyc 1800 Touring, due to its high protection rating, may be mounted in any position either sheltered from or exposed to the elements.

6.1 Installing the unit in weather-protected areas

Panorama Cyc 1800 Touring may be situated in any mounting position when operated in sheltered areas.



So that it can be used in a variety of positions, the **Panorama Cyc 1800 Touring** is fitted with four rubber feet on its base which may, as you will note, be removed should you wish to permanently install the unit by affixing the base to solid surface.

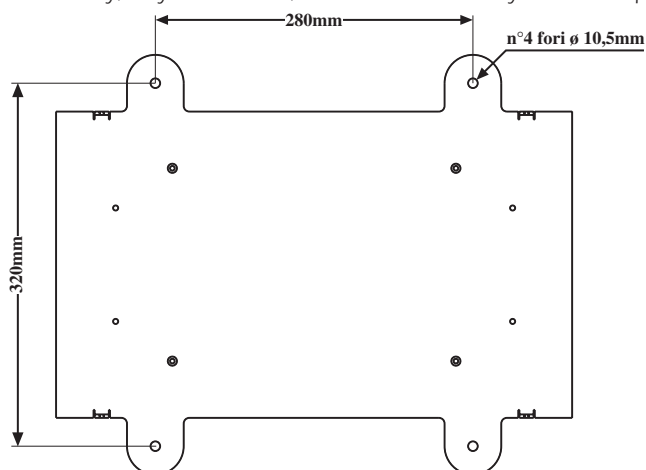

When hanging the unit, the four rubber feet may be removed. Ensure that the suspending structure is able to safely take the weight of the unit. Suspending the unit via clamps is particularly simple when using the optional mounting plate (**coemar** code GA-8734.116), as shown in the diagram it offers a secure and safe mounting method.

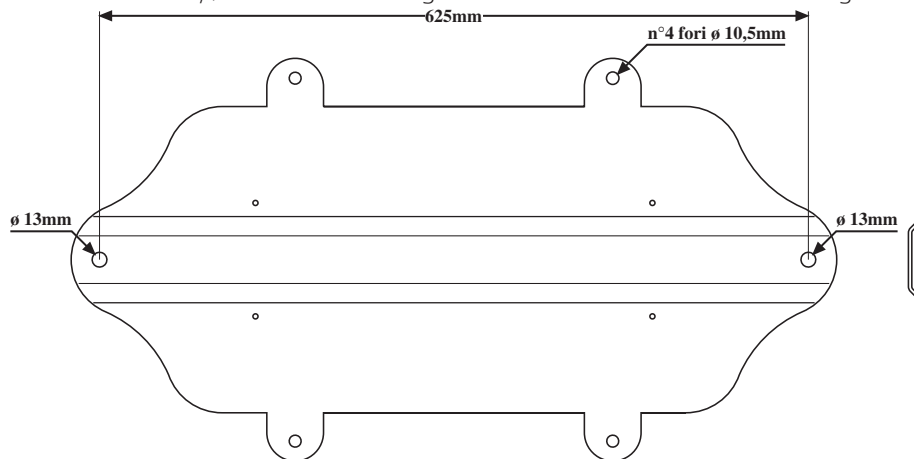

6.2 Installing the unit in exposed areas

Panorama Cyc 1800 Touring may be situated in several mounting positions when installed in an exposed area, thanks to its IP 44 protection rating. To ensure proper installation, however, there is a simple guideline to follow:

Attention!

As indicated in the diagram, the base of the unit must always be facing the ground.



Panorama Cyc 1800 Touring allows the beam of light to be tilted in the range of -35° to $+75^{\circ}$ without having to move any other component except the head of the fixture.

Mounting the unit incorrectly may cause damage to occur and incorrectly mounting the unit will immediately void the warranty.

If mounted in any other position other than with the base down, the projector will not be performing with its maximum protection rating, although, with adequate covering, it may operate in almost any position.

6.3 Mounting the ballast

The ballast of the **Panorama Cyc Touring** may be mounted in any position. Its protection rating is IP 55 and it is therefore able to be mounted in any exposed position.

It may be affixed to any structure using the 4 holes in the base of the ballast.

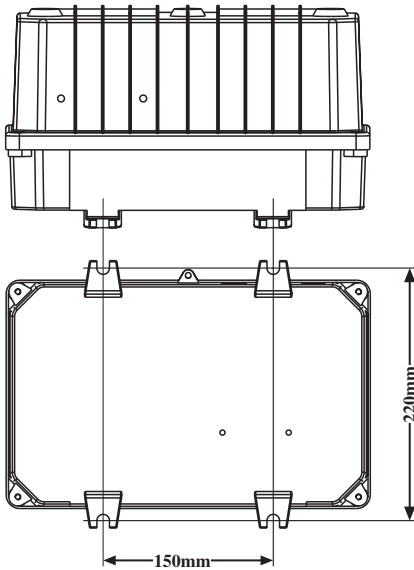

An optional mounting plate (**coemar** code GA-8734.116) may be a useful addition if mounting the unit using clamps and suchlike.

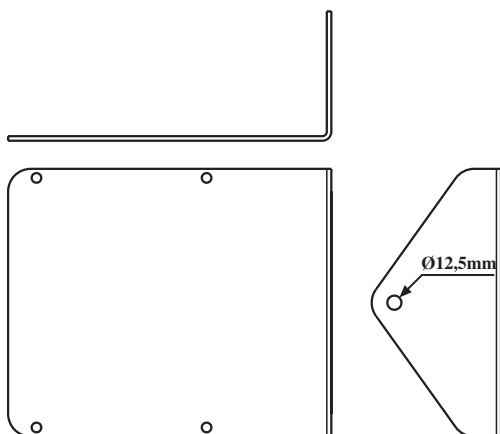

safety chain

When hanging the ballast, we recommend the use of two safety chains (cod. 069) fixed to the ballast and to the primary fixing structure to avoid it falling in case (however unlikely) the primary fixing point should fail.

If using an after-market safety chain not manufactured by **coemar**, ensure that it is of sufficient rating to hold the weight of the fixture.

risk of fire

Each fixture produces heat and must be installed in a well-ventilated position. The minimum recommended distance from flammable material is: 0.5m. Minimum distance from the object being illuminated is: 2 m.

7. Mains connection

Connecting the ballast to the Panorama Cyc 1800 Touring

- 1) Locate the power cable on the projector. The **Panorama Cyc 1800 Touring** uses a 6 pole 32 amp connector.
- 2) Insert this plug into the respective socket on the ballast, making sure that the mechanical clip is moved into place to secure the plug.

Panorama Cyc 1800 Touring features 3,5 metres of cable between the ballast and the projector; should you require, extension cables are available from coemar:

- 10m extension cable **coemar** cod. 9204/2
- 20m extension cable **coemar** cod. 9204/3

You may extend the distance as required by simply using the appropriate extension cable.

Should these standard extension cables not suffice for your task, refer the matter to your authorised coemar service centre for advice.

cabling

The mains cable provided is thermally resistant, complying to the most recent international standards. It meets or exceeds the VDE and IEC norms, IEC 331, IEC 332 3C, CEI 20 35.

NB: In case of cable replacement, similar cable with comparable thermal resistant qualities must be used exclusively (cable 3x1.5 ø external 10 mm, rated 300/500V, tested to 2KV, operating temperature -40° +180°, **coemar** cod. CV5309).

mains connection

Panorama Cyc 1800 Touring can operate at voltages from 208V-230V-240V at 50 or 60Hz (operating voltage and frequency can be selected as described in section 5 of this manual).

Prior to connecting the unit to your mains supply, ensure that the model in your possession correctly matches the mains supply available to you.

For connection purposes, ensure your plug is of a suitable rating: 13,3 amps during startup and 9 amps during normal operation. Locate the mains cable which exits the ballast and connect as shown below:

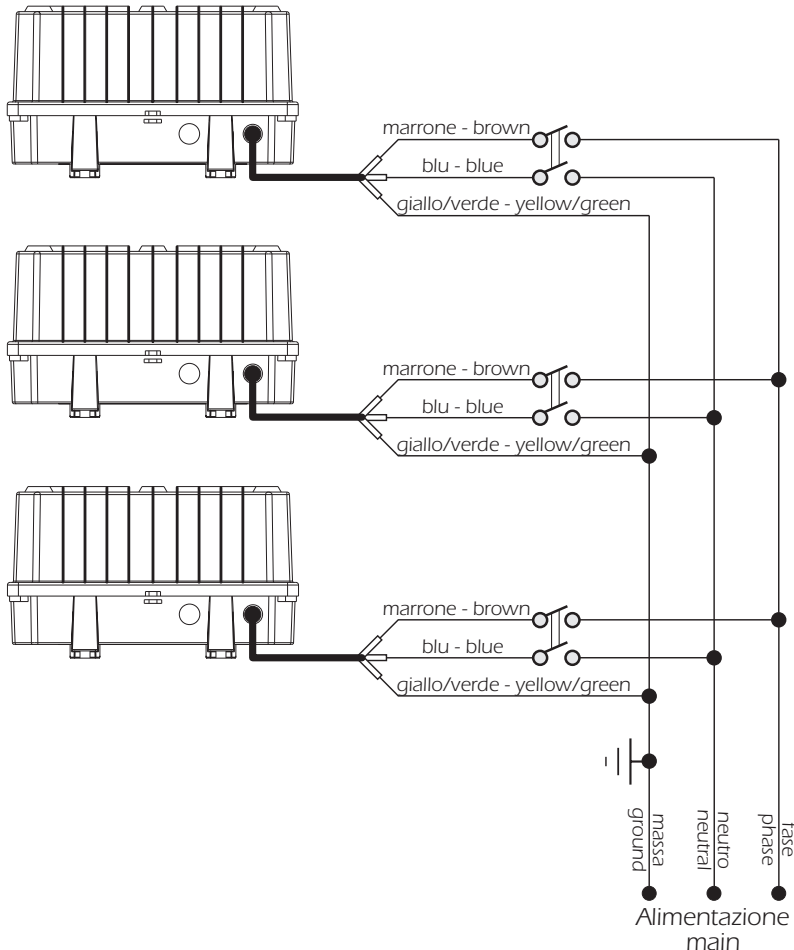

protection

The use of a thermal magnetic circuit breaker is recommended for each **Panorama Cyc 1800 Touring**.

A good earth connection is essential for the correct operation of the fixture. Strict adherence to regulatory norms is strongly recommended.

Panorama Cyc Touring must be earthed; never install the unit unless the yellow/green earth cable is securely connected.

8. Signal connection

Panorama Cyc Touring may operate in 3 different modes:

8.1 Automated operation

8.2 Using DMX 512 signal

8.3 Synchronising Panoramas without DMX 512 signal.

Different connections should be made, basing to the choosen operating mode.

8.1 Automated operation

Panorama Cyc 1800 Touring may operate in stand alone mode in the absence of control signal, using pre-programmed colour changing sequence which can be activated by the multi-function panel on the unit.

No incoming signal to the XLR3 sockets should be connected.

We recommend that the XLR 3 sockets be isolated by using suitably sheathed weather-proof dummy plugs.

This ensures that the weather rating of the **Panorama is maintained**; **coemar** supplies two XLR 3, IP 67 rated plugs for this purpose; in case of replacement pls. use identical plugs.

8.2 Using DMX 512 signal

Control signal is digital, and is transmitted via two pair screened $\varnothing 0.5\text{mm}$ cable.

Connection is serial, utilising the XLR 3 sockets located on the base of the **Panorama Cyc 1800 Touring**.

We recommend that the last link in the DMX chain be isolated by using suitably sheathed weather-proof dummy plugs.

This ensures that the weather rating of the **Panorama is maintained**; **coemar** supplies two XLR 3, IP 67 rated plugs for this purpose; in case of replacement pls. use identical plugs.

A connection using the 3 Pin XLR 3

Connection is to international standards:

- pin 1= gnd
- pin 2= data -
- pin 3= data +

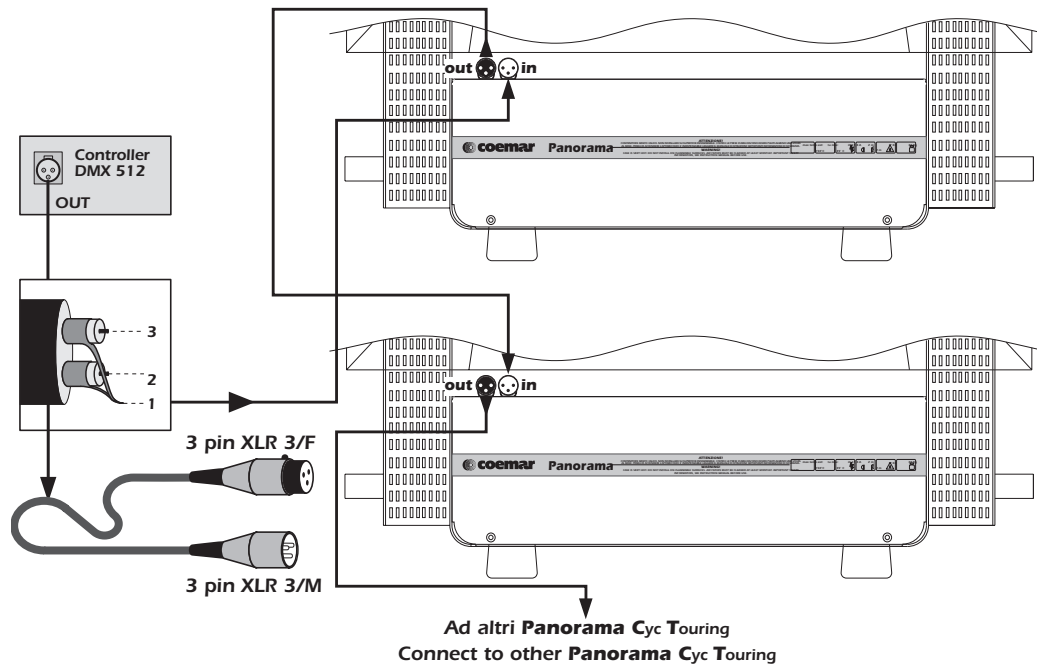

Ensure that all data conductors are isolated from one another and the metal housing of the connector.

Note: the housing of the XLR 3 must be isolated.

Should your **DMX 512** controller output via an XLR 5 socket, the polarity of pins 1, 2 and 3 must be maintained and pins 4 and 5 should remain unconnected.

Connection is to international standards:

- pin 1= gnd
- pin 2= data -
- pin 3= data +
- pin 4= optional - not connected
- pin 5= optional + not connected

8.3 Synchronising Panoramas without DMX 512 signal

Multiple **Panorama Cyc 1800 Touring** units may be interconnected in the absence of DMX 512 signal, operating simply via the inbuilt programs within the **Panorama unit**.

All the **Panorama Cyc 1800** **thus connected will operate simultaneously** with one unit acting as MASTER and all subsequent units as a SLAVE.

Determine which of the **Panorama Cyc 1800 Touring** will act as master, usually by the criterion of ease of access:

Using XLR 3 connectors, daisy-chain the units with the master connected to the first slave, and then slave to slave, up to a maximum of 10 units in total.

Should you need to connect more than 10 units we recommend that you use a suitable dmx splitter box to achieve this. These units are usually opto-isolated and may amplify and repeat the signal as required.

Attention! We recommend that any unused sockets be terminated to preserve the weather protection rating of the units. We recommend that these links in the DMX chain be isolated by using suitably sheathed weather-proof dummy plugs.

This ensures that the weather rating of the **Panorama is maintained**; **coemar** supplies two XLR 3, IP 67 rated plugs for this purpose, in case of replacement pls. use identical plugs.

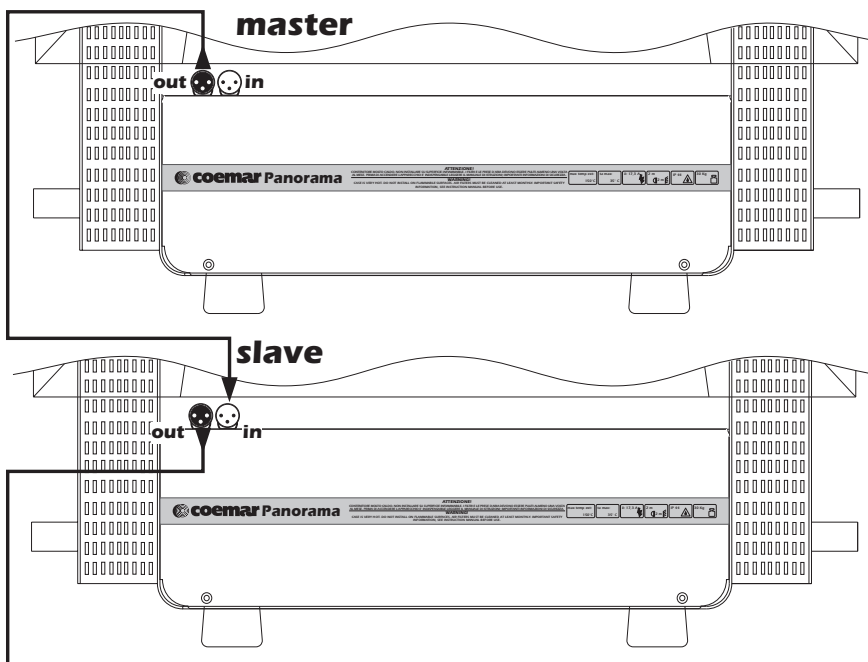

**Ad altri Panorama Cyc Touring (Slave)
Connect to other Panorama Cyc Touring (Slave)**

Connection is to international standards:

- pin 1= gnd
- pin 2= data -
- pin 3= data +

Ensure that all data conductors are isolated from one another and the metal housing of the connector.

Note: The housing of the cannon XLR 3 must be isolated.

9. Powering up

After having followed the preceding steps, turn on the DMX 512 controller which will be used to control the **Panorama Cyc 1800 Touring**. Following this, turn on the power to the unit, and turn on the unit's power switch. **The fixture will perform a reset function on its internal motors. This will last some few seconds, after which it will be subject to the external signal from the controller.**

DMX led

The DMX led will be static on to indicate that **DMX 512** signal is being correctly received.

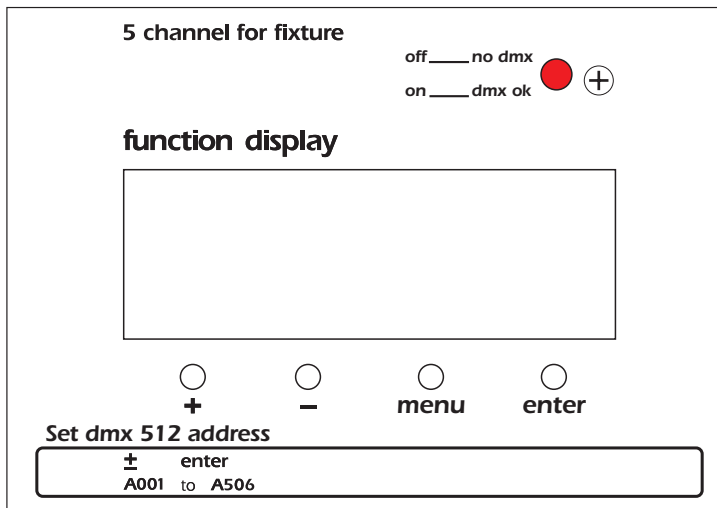

If the led is off, the projector is not receiving signal. check the cabling and the functioning of the controller.

10. DMX addressing

Each **Panorama Cyc 1800 Touring** utilises **5 channels of DMX 512 signal for complete control.**

To ensure that each unit accesses the correct signal, it is necessary to correctly address each fixture. Any number between 1 and 506 can be generated via the multifunction panel of the **Panorama Cyc 1800 Touring.**

This procedure must be carried out on every **Panorama Cyc 1800 Touring** being used.

When powered up initially, each projector will show **A001** which indicates **DMX address 1**; a projector thus addressed will respond to commands on channels **1 to 5** from the **DMX 512 controller.** A second projector should be addressed as 6 a third as **11** and so on until the final **unit has been addressed.**

Altering DMX addresses

- 1) Press the + or - button until the display shows the **DMX** required, the characters in the display panel will flash to indicate that the selection is not stored in memory.

function display

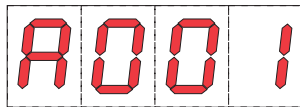

+ - menu enter

- 2) Press the enter button to confirm your selection; the display will stop flashing and the projector will now respond to the new DMX address.
- 3) To better understand the function of each channel, we refer you to section 12 "Control channel functions from a DMX 512 controller".

Important Note: Keeping the + or - button pressed will cause the display to alter at increased speed, allowing a faster selection to be effected.

11. DMX 512 signal

Panorama Cyc 1800 Touring may be operated using DMX 512 signal, connection is described in section "8.2 Using DMX512 signal".

If you have followed all instructions correctly to this point, the 5 channels of your **DMX 512** controller will have control of all the functions of the **Panorama Cyc 1800 Touring** as shown in the following table:

channel	function	type of control	effect	decimal
1	dimmer	step	closed	0-7
		proportional	from close to open	8-255
2	cyan	proportional	proportional cyan control from white to cyan	0-255
3	magenta	proportional	proportional magenta control from white to magenta	0-255
4	Yellow	proportional	proportional yellow control from white to yellow	0-255
5	function	step	lamp off	0-114
			motor reset	115-140
			lamp on	141-255
Back panel can modify function channel (inhibit lamp off)				
5	function	step	lamp on	0-114
			motor reset	115-140
			lamp on	141-255
note 1: 2 or 4 numbers close to the end limit levels cannot be used as unstable levels				
note 2: function channel has a delay time of 6 second to prevent accidental activation.				
note 3 :on/off lamp mode is not affected unless an opposite value is received				

To remotely control lamp ignition, you must position channel 5 at a level between 141 and 255.

12. Automated operation

The **Panorama Cyc 1800 Touring** may operate without external signal, executing two pre-programmed colour changes as discussed in section "8.1 Automated operation".

To engage the automated programs, after having turned on power to the unit, use the four buttons on the multi-function display to select from the options available:

- 1- Activate the automated colour changing programs (**AUTO ON**)

A001 — menu — +o— **AUTO** **automatic movement** — enter — +o— **ON** — enter —
 to activate colour changing effects without using an external control signal to enable the function

- 2- Select from the two programs available; the 1° program (**PRO1**) utilises a 32 colour sequence, the 2° program (**PRO2**) utilises 55.

A001 — menu — +o— **PROG** **program** — enter — +o— **PRO1** — enter —
 Program selection in auto mode (2 selections available) | program n° 1
 +o— **PRO2** — enter —
 program n° 2

- 3-Adjust the hold time for each colour in the sequence, if you wish to alter from the 0 set as the **coemar** default.

A001 — menu — +o— **AUSP** **colour changing program speed execution** — enter — +o— **from -000** — enter —
 Stay time and adjustment of one colour in the beam (program 1 or 2). | minimum speed
 +o— **to -661** — enter —
 maximum speed

- 4-Adjust the fade time between the colours, if you wish to alter from the **STRD** set as **coemar** default.

A001 — menu — +o— **COLR** **colour changer speed** — enter — +o— **STRD** — enter —
 Colour changing system operating time speed on DMX signal variation. | standard speed
 +o— **SLOW** — enter —
 low speed

Note: Projectors in automated mode will have the lamp turn on immediately and will be unable to have control of their dimmer modified.

13. Synchronising several Panoramas without using DMX 512 signal

Multiple **Panorama Cyc 1800 Touring** units may be used in synchronised mode to use the automated preset programs without the need for an external control signal by completing the following procedure.

Panorama units connected together will operate in a master/slave mode.

The units may be synchronised to operated simultaneously or may be operated so that the “slave” units, as selected, operate with independent time delays:

To set up automated mode, complete the procedure described in section “**8.3 Synchronising Panoramas without using DMX 512 signal**”, then set up the automated function with the four multi-function display buttons.

13.1 Setting up a “master”

Only one projector may be set up as “**Master**” the initial projector in the dmx daisy chain and the only one with its “**DMX IN**” socket empty.

- 1- Set up a unit as **master** (**MAST**).

A001 — menu — +o— **MA SL** **master or slave** — enter — +o— **MAST** — enter —
 to assign a code to the projectors as **master** (generator) or **slave** (receiver).
 projector **master**

- 2- Activate the automated program (**AUTO ON**)

A001 — menu — +o— **AUTO** **automatic movement** — enter — +o— **ON** — enter —
 to activate colour changing effects without using an external control signal
 to enable the function

- 3- Select from the two programs available; the 1° program (**PRO1**) utilises a 32 colour sequence, the 2° program (**PRO2**) utilises 55.

A001 — menu — +o— **PROG** **program** — enter — +o— **PRO1** — enter —
 Program selection in auto mode (2 selections available)
 |
 program n° 1
 +o— **PRO2** — enter —
 program n° 2

- 4- Adjust the hold time for each colour in the sequence, if you wish to alter from the 0 set as the **coemar** default.

A001 — menu — +o— **AUSP** **colour changing program speed execution** — enter — +o— **from -000** — enter —
 Stay time and adjustment of one colour in the beam (program 1 or 2).
 |
 minimum speed
 +o— **to -661** — enter —
 maximum speed

- 5- Adjust the fade time between the colours, if you wish to alter from the **STRD** set as **coemar** default.

A001 — menu — +o— **COLR** **colour changer speed** — enter — +o— **STRD** — enter —
 Colour changing system operating time speed on DMX signal variation. (selection between standard and slow)
 |
 standard speed
 +o— **SLOW** — enter —
 low speed

Note: Projectors in automated mode will have the lamp turn on immediately and will be unable to have control of their dimmer modified.

13.2 Setting up “slave” units

All units being operated from the master unit must be set to “Slave” mode.

They must be connected correctly in the dmx daisy chain, see section **8.3 Synchronising Panorams without DMX 512 signal**

Projectors set up as “Slave” are recognisable as they are the only ones with both dmx in and out sockets connecte (with the exception of the last in the series which has only its “DMX IN” socket utilised).

The procedure for setting up a unit as a “Slave” is as follows:

- 1- Set up the unit as “Slave” (*SLAV*).

A001 — menu — +0 — *M.A.S.L* master or slave — enter — +0 — *SLAV* projector slave — enter — *-SL-*
 to assign a code to the projectors as
master (generator) or **slave** (receiver).

When the display show *-SL-* you have correctly set the projector as a **Slave** which will follow the signal sent to it by the master unit.

The display options now offered by the **Panorama** are much simplified to those of the master.

- 2- At this point, you may alter the delay time of the individual slave unit to that of its master.

-SL- — menu — +0 — *AUOL* delayed synchronization — enter — +0 — from *0000* — enter —
 To set the delay time on synchronization
 of colour changing program set on master device.
 This function can be seen and activated only
 on slave unit *-SL-* **slave**.
 no delay
 to *0055*
 maximum delay

The delay may be altered from 0 to 55 and relates to the point at which the slave will commence its colour change sequence with respect to that being generated by the master.

For example:

Synchronising two projectors with *AUOL*= 20.

When the Master reaches the 20th colour in its colour change sequence, the slaves set to *AUOL 20* will begin with the first colour.

The synchronising continues until the projectors are turned off.

The *AUOL* function thereby allows different areas of your lighting subject to be in lit in diverse colors whilst maintaining the sequence amongst them (as set by the master).

14. Display panel functions















































On display panel of **Panorama Cyc 1800** are shown all the functions available; it is possible to change some of those parameters and to add some functions.

Changing the setting made by **coemar** can vary the functions of the device that will not respond to the DMX 512 mixer used to control it. Please carefully follow the instructions, before applying any variations or selections.

NOTE: the symbol  shows which key has to be pushed to obtain the function desired.

A001  menu	  DIMM dimmer speed Mechanical dimmer operating time speed on DMX signal variation. (selection between standard and slow)	 enter	  STRD  enter standard speed	  SLOW  enter low speed
  COLR colour changer speed Colour changing system operating time speed on DMX signal variation. (selection between standard and slow)	 enter	  STRD  enter standard speed	  SLOW  enter low speed	
  LAMP lamp function Lamp on/off control inhibition by DMX signal (channel 5)	 enter	  STRD  enter ignition by DMX 512	  ON  enter lamp always on	
  TEST test function Device operation test without DMX signal	 enter	  TO1  enter dimmer test	  TO4  enter yellow colour test	
  RESE reset Reset function	 enter	  --- reset activation		
  RATE DMX speed DMX signal reception speed	 enter	 24.50 numeric value		
  HOUR working time (in hour) Visualization of projector's working time (time covered by mains supply)	 enter	 0280 numeric value shown in hours		
  LIFE lamp life (in hour) Visualization of lamp life (time covered by mains supply from last reset operation)	 enter	  0340 numeric value shown in hours		

Functions described on paragraph 12 and 13.

A001  menu	  AUTO automatic movement to activate colour changing effects without using an external control signal	 enter	  OFF  enter to disable the function	  ON  enter to enable the function
  MASL master or slave to assign a code to the projectors as master (generator) or slave (receiver).	 enter	  MAST  enter master	  SLAV  enter slave	 -SL- confirm slave
  AUSP colour changing program speed execution Stay time and adjustment of one colour in the beam (program 1 or 2).	 enter	  from -000  enter minimum speed	  to -667  enter maximum speed	
  PROG program Program selection in auto mode (2 selections available)	 enter	  PRO1  enter program n° 1	  PRO2  enter program n° 2	
  AUDL delayed synchronization To set the delay time on synchronization of colour changing program set on master device. This function unit can be seen and activated only on slave unit -SL- slave.	 enter	  from 0000  enter no delay	  to 0055  enter maximum delay	

15. Mechanical adjustments

After having powered up the projector and set up either DMX 512 or automated control of the functions of the **Panorama**, you may wish to perform the following mechanical adjustments to optimise the output of the unit in your installation.

15.1 Tilt adjustments

Loosen the knobs at the sides of the unit which allow adjustment (+75° -35°) of the tilt position of the beamspread.



After having set up the position as required, remember to tighten the knobs once again to avoid movement.

15.2 Barndoor adjustments

The **Panorama Cyc 1800 Touring** features a 4 leaf barndoor which is set in the full closed position for transportation. It can be used to alter the beamspread to suit your particular application.

- 1) On each supporting arm of the barndoor leaves you will find a screw, loosen this for adjustment.
- 2) Adjust the angle of each leaf to suit your installation.
- 3) After adjusting your leaf position, ensure that the screws are securely tightened to avoid sagging.
- 4) In the packaging of the unit are included 8 trapezoidal aluminium pieces; these are used to supplement the effect of the barndoor by fitting into the corners to mask out any stray light from the unit.
- 5) Affix the 8 segments using the 16 screws included for this purpose, thereby completing the masking effect of the barndoor.
- 6) Make sure all adjusting screws are securely tightened to ensure there is no movement of the barndoors from their set position.



Attention! The barndoor should always be open prior to turning on the lamp. Failure to do so could result in the unit overheating and cause significant internal damage.

15.3 Alternating beam angles by inserting diffusion filters

The **Panorama Cyc 1800 Touring** is able to offer 4 variations on the beamspread produced by the unit, thereby offering greater flexibility in its output:

- A) 62° on the vertical axis, 58° on the horizontal: using the standard filter
- B) 52° on the vertical axis, 96° on the horizontal: using the horizontal stretch filter
- C) 96° on the vertical axis, 65° on the horizontal: using the vertical stretch filter
- D) 30° on the vertical axis, 50° on the horizontal: using no filter

To obtain any of the 3 angles other than that offered by the standard filter you should proceed as follows.

Attention:

Never look directly into the light beam, there is a danger from ultraviolet radiation.

Prior to undertaking this procedure, either turn off the projector or turn on the dimmer.

- 1) Use a suitable screwdriver to remove the screws which hold in place the diffusion filter.

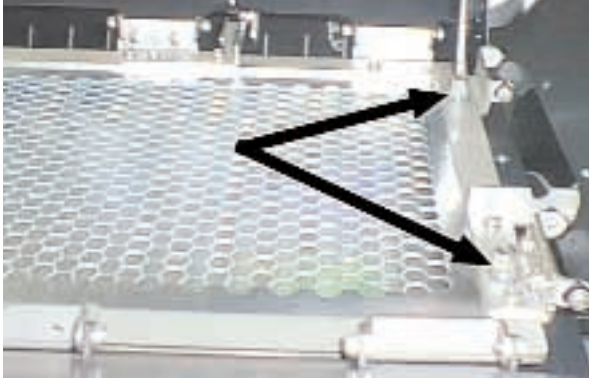

- 2) Remove the diffusion filter.



- 3) Insert the new filter.

- 4) Replace the four screws which hold the filter in place.

16. Thermal protection

A thermal sensor located in the body of the **Panorama Cyc 1800 Touring** protects the unit from overheating. Should the unit overheat due to it being poorly ventilated or the ambient temperature be too high or a cooling fan fail, the thermal sensor will cause voltage to be removed from the lamp circuit.

17. Maintenance

Whilst every possible precaution has been taken to ensure the trouble-free operation of your **Panorama Cyc 1800 Touring**, the following periodic maintenance is highly recommended. Make sure that mains power is disconnected prior to performing any maintenance.

Attention

Disconnect mains power prior to opening the inspection lid

periodic cleaning lenses and reflectors

Even a fine layer of dust can reduce the luminous output substantially. Regularly clean all lenses and the reflector using a soft cotton cloth, dampened with a specialist lens cleaning solution. To do this, remove the two screws at the sides of the safety glass. Same cleaning solutions can be used to clean the reflector.

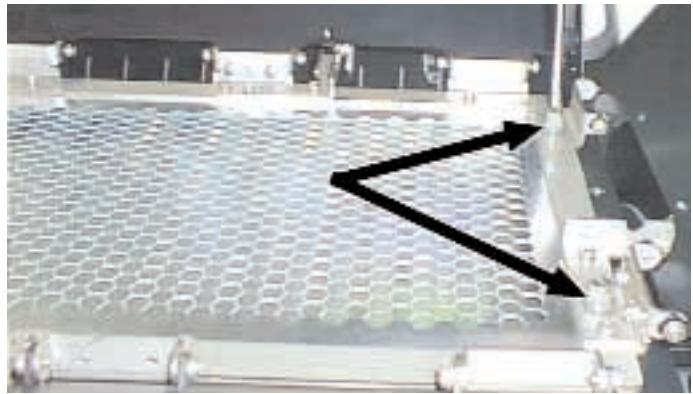

periodic maintenance lamp

The lamp should be replaced if there is any observable damage or deformation due to heat. This will avoid the danger of the lamp exploding; you may gain access to the lamp as described in section 4. Open the rear panel of the unit using the handle placed there for his purpose.

fans and air passages



The fans and air passages must be cleaned approximately every 6 weeks; the period for this periodic cleaning will depend, of course, upon the conditions in which the projector is operating. Suitable instruments for performing this type of maintenance are a brush and a common vacuum cleaner or an air compressor. To gain access to the fans at the side of the unit, remove the protective covers located there.

filters and air inlets

the filters and air inlets must be cleaned regularly to ensure the unit operates correctly. This should be undertaken at least every 4 weeks, the period for this periodic cleaning will depend, of course, upon the conditions in which the projector is operating.

To gain access to the filter, remove the two screws which hold it in place, located at the rear of the unit. Suitable instruments for performing this type of maintenance are a brush and a common vacuum cleaner or an air compressor. Should this not suffice, the filter itself may be immersed in a cleaning detergent.



mechanicals

Periodically check all mechanical devices for wear and tear; gears, guides, belts, etc., replacing them if necessary. Ensure the screws affixing the barndoors are firmly tightened.

**electrical components**

Check all electrical components for correct earthing and proper attachment of all connectors, refastening if necessary.

dichroic filters

To properly clean the dichroic filters it is necessary to remove the screws which affix the front block of the unit. The front block of the unit, together with its seal, will come away.

Move each dichroic filter manually to allow access to it and clean with a suitable glass cleaning detergent.

Attention! Once you have completed the cleaning procedure, make sure that the seal is correctly replaced when replacing the front block.

Should you fail to do this, the protection rating of the unit will be compromised, and the internal of the unit may be subject to the adverse effects of the weather. This may result in damage to these components.

fuse replacement

To replace the fuse it is necessary to remove the two housing plates and open the terminal cover box as described in the section entitled "Selecting the operating voltage of the transformer" then replacing the fuse as required. Note that the fuse must be replaced with one of similar value.

18. Electronic motor alignment

RESERVED FOR INSTALLERS ONLY

The display panel on the **Panorama Cyc 1800 Touring** allows for the electronic calibration of the units motors; this procedure is undertaken by **coemar** at predelivery; it may be useful to perform this procedure in the case of internal components being replaced.

Altering the factory settings may radically alter the functioning of the projector. Carefully read all of the following prior to attempting any changes.

electronic calibration

Important Note: electronic calibration is only possible if the projector is connected to a **DMX 512** source.

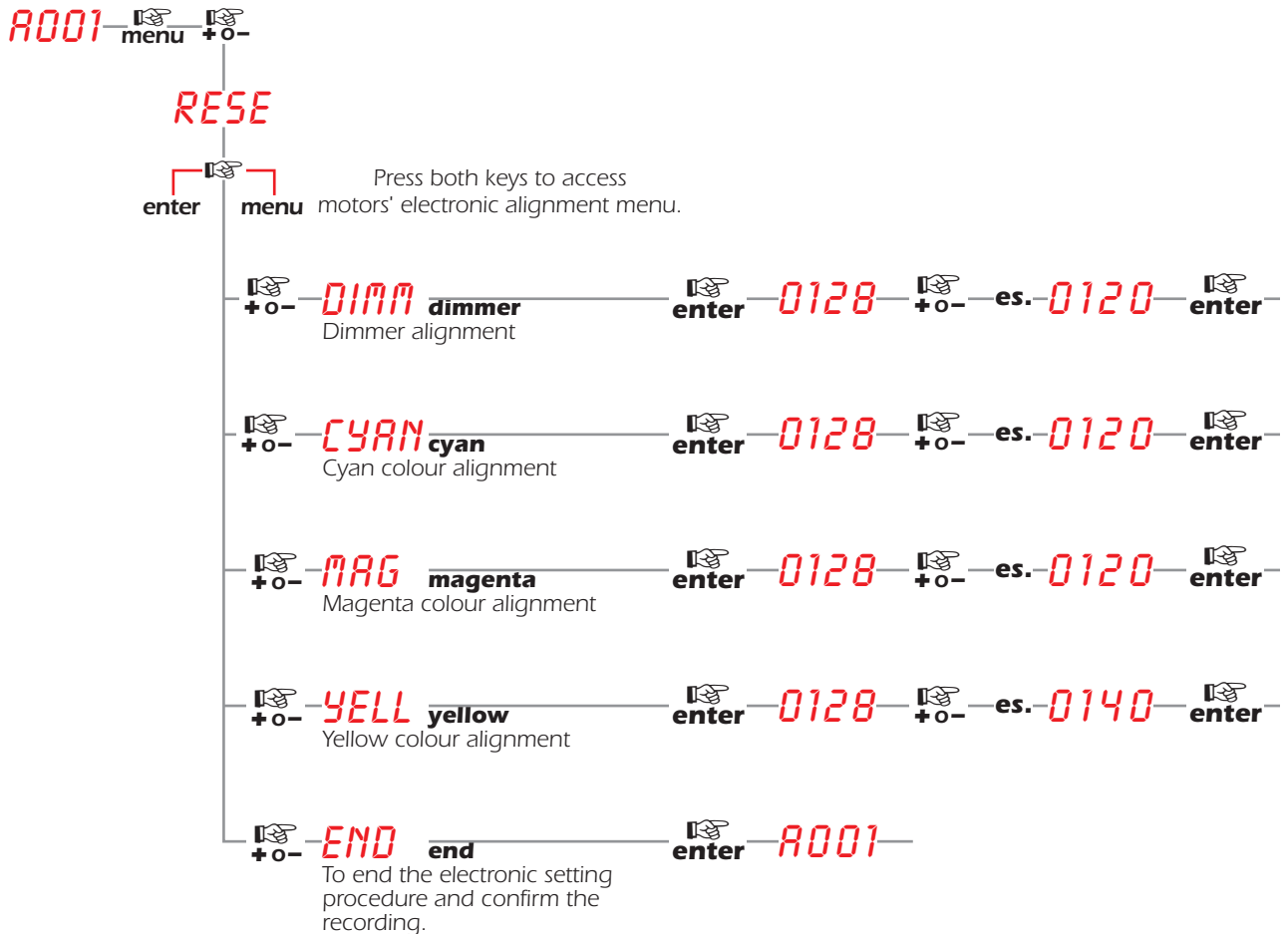

Important Note: At the termination of the above electronic calibration procedure, if the END function is not performed, no memory changes will be effected. This allows the operator to abort any changes made, in case of operator error.

19. Spare parts

All the components of the **Panorama Cyc 1800 Touring** are available as replacement spares from your authorised **coemar** sales agent.

Accurate description of the fixture, model number, and type will assist us in providing for your requirements in an efficient and effective manner.