



WASH 575 EB

coemar

**manuale
di istruzioni
instructions
manual**

**1^a edizione, luglio 2002
1st edition, july 2002**

iWASH 575 EB

numero di serie/serial number

data di acquisto/date of purchase

fornitore/retailer

indirizzo/address

cap/città/suburb

provincia/capital city

stato/state

tel./fax/

*Prendete nota, nello spazio apposito, dei dati relativi al modello e al rivenditore del vostro **iWASH 575 EB**: in caso di richiesta di informazioni, pezzi di ricambio, servizi di riparazione o altro ci permetteranno di assistervi con la massima rapidità e precisione.*

*Please note in the space provided above the relative service information of the model and the retailer from whom you purchased your **iWASH 575 EB**: This information will assist us in providing spare parts, repairs or in answering any technical enquiries with the utmost speed and accuracy.*

ATTENZIONE: la sicurezza dell'apparecchio è garantita solo con l'uso appropriato delle presenti istruzioni, pertanto è necessario conservarle.

WARNING: the security of the fixture is granted only if these instructions are strictly followed; therefore it is absolutely necessary to keep this manual.

Index

- 1. Packaging**
- 2. Transportation**
- 3. Important safety information**
- 4. Lamp: installation and replacement**
- 5. Operating voltage and frequency**
- 6. Installation**
- 7. Mains connection**
- 8. Signal connection**
- 9. Powering up**
- 10. DMX addressing**
- 11. Display panel functions**
 - 11.1. Function settings (FUNC)**
 - 11.2. Measure and test (MEAS)**
 - 11.3. Quick guide to menu navigation**
 - 11.4. Rapid scrolling**
- 12. DMX 512 channel functions**
- 13. Aligning the lamp in the optical path**
- 14. Turning on the iWASH 575 EB without movement**
- 15. Resetting the counter**
- 16. Automatic realignment**
- 17. Opening up the projector**
- 18. Altering the operating voltage (reserved for technical personnel)**
 - 18.1. Selecting the transformer voltage**
- 19. Thermal protection**
- 20. Lamp circuit protection**
- 21. Maintenance**
- 22. Electronic motor alignment**
- 23. Error messages**
- 24. Spare parts**

English

Congratulations on having purchased a coemar product. You have assured yourself of a fixture of the highest quality, both in componentry and in the technology used. We renew our invitation to you to complete the service information on the previous page, to expedite any request for service information or spares (in case of problems encountered either during, or subsequent to, installation). This information will assist in providing prompt and accurate advice from your coemar service centre.

1. Packaging

Following the instructions and procedures outlined in this manual will ensure the maximum efficiency of this product for years to come.

Open the packaging and ensure that no part of the equipment has suffered damage in transit. In case of damage to the equipment, contact your carrier immediately by telephone or fax, following this with formal notification in writing.

packing list

Ensure the packaging contains:

- 1 **iwASH 575 EB**
- 1 **instruction manual**
- 2 **cam-lock projector supports**

2. Transportation

The **iwASH 575 EB** should be transported in its original packaging or in a coemar approved flight case. In order to manufacture a suitable flight case, we recommend that it be constructed in such a manner as to stop the articulated movement of the **iwASH 575 EB**.

3. Important safety information

Fire prevention:

1. **iwASH 575 EB** utilises a Phillips **575 MSD** or **575 MSR/2** lamp; the use of any alternative lamp is not recommended and will null and void the fixture's warranty.
2. Never locate the fixture on any flammable surface.
3. Minimum distance from flammable materials: 0,5 m.
4. Minimum distance from the closest illuminable surface: 2 m.
5. Replace any blown or damaged fuses only with those of identical values. Refer to the schematic diagram if there is any doubt.
6. Connect the projector to mains power via a thermal magnetic circuit breaker.

prevention of electric shock:

1. High voltage is present in the internals of the unit. Isolate the projector from mains supply prior to performing any function which involves touching the internals of the unit, including lamp replacement.
2. For mains connection, adhere strictly to the guidelines outlined in section 7 of this manual.
3. The level of technology inherent in the **iwASH575 EB** requires the use of specialised personnel for all service applications; refer all work to your authorised **coemar** service centre.
4. A good earth connection is essential for proper functioning of the projector.
Never operate the unit without proper earth connection.
5. The fixture should never be located in an exposed position, or in areas of extreme humidity. A steady supply of circulating air is essential.

Protection against ultraviolet radiation:

1. Never turn on the lamp if any of the lenses, filters, or the carbon fibre housing is damaged; their respective functions will only operate efficiently if they are in perfect working order.
2. Never look directly into the lamp when it is operating.

Safety:

1. The projector should always be installed with bolts, clamps, and other fixings which are suitably rated to support the weight of the unit.
2. Always use a secondary safety chain of a suitable rating to sustain the weight of the unit in case of the failure of the primary fixing point.
3. The external surface of the unit, at various points, may exceed 150°C. Never handle the unit until at least 10 minutes have elapsed since the lamp was turned off.
4. Always replace the lamp if any physical damage is evident.
5. Never install the fixture in an enclosed area lacking sufficient air flow; the ambient temperature should not exceed 35°C.
6. A hot lamp may explode. always wait for at least 10 minutes to elapse after the unit has been turned off prior to attempting to replace the lamp.
Always wear suitable hand protection when handling the lamp.

Protection against penetration by external agents

1. The fixture is classified ordinary device ; its protection grade against penetration by external agents,solid or liquid, is IP 20

4. Lamp: installation and replacement

iWASH 575 EB utilises a Philips 575 MSD or a Philips 575 MSR/2 lamp at 575 watts with a GX 9,5 lamp base. The lamp is available from your authorised **coemar** sales agent.

Philips 575 MSD

coemar cod.	105215
power	575 w
luminous flux	43.000 lm
colour temperature	6000° K
base	GX 9,5
approximate lamp life	3000 hours

Philips 575 MSR/2

coemar cod.	105245/2
power	575 w
luminous flux	49.000 lm
colour temperature	7.200° K
base	GX 9,5
approximate lamp life	1 000 hours

Attention

Turn off mains power prior to opening up the unit

The fixture's internal temperature can reach 250° C after 5 minutes, with a maximum peak of 350° C; ensure that the lamp is cold prior to attempting removal. The fixture should be allowed to stand and cool for 10 minutes prior to its removal. MSR/SA lamps are part of the mercury vapour family of discharge lamps and must be handled with great care. The lamp operates at high pressure, and the slight risk of explosion of the lamp exists if operated over its recommended life of 1000/3000 hours. We recommend, therefore, that the lamp be replaced within the manufacturer's specified lamp life.

installing the lamp

- 1) Using a Phillips head screwdriver, remove the screws **(A)** which hold the lampholder assembly in place, located at the rear of the projector head.

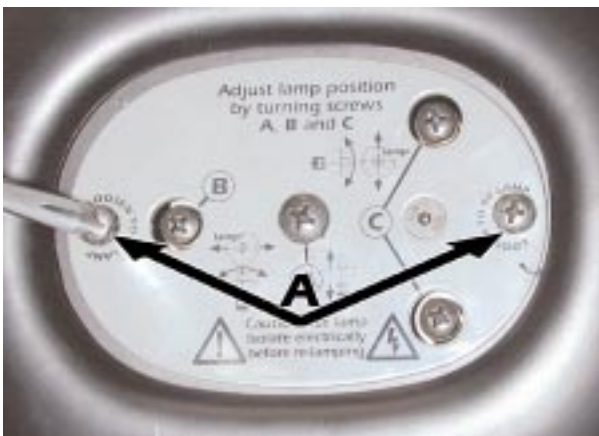

- 2) Remove the lampholder assembly **(B)**

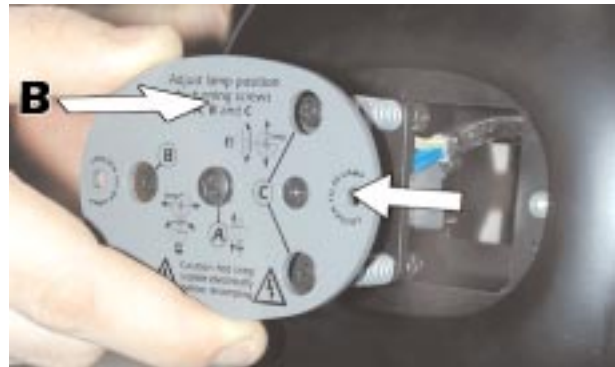

- 3) Locate the lampholder **(C)**

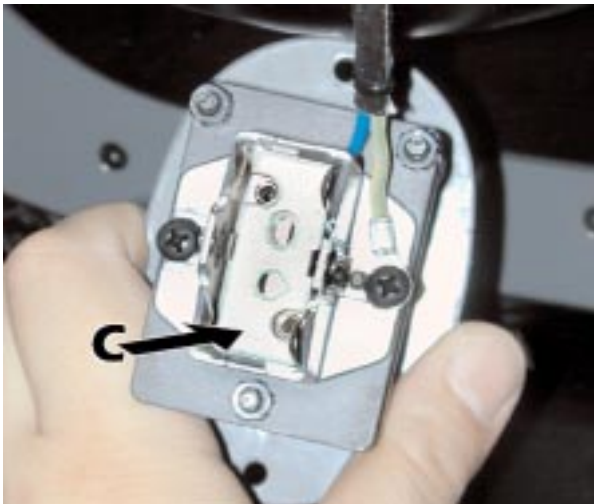

English

4) Insert the lamp

The lamp used is manufactured from quartz glass and should be handled with care; always adhere to the instructions supplied in the lamp's packaging. Never touch the glass directly, use the tissue provided in the lamp's packaging. The GX 9,5 lampbase is symmetrical in construction. **DO NOT USE UNDUE FORCE.** In case of difficulty, re-read the instructions and repeat the procedure.



5) Replace the lamp assembly and replace and tighten the screws (A) which were previously removed.



Attention: we recommend that the lamp be realigned in the optical train of the unit to avoid overheating of the dichroic filters and other internal components of the unit. refer to section **13** for instructions about this procedure.

5. Operating voltage and frequency

The projector may operate at voltages including 100, 115, 208, 230 or 240 V. **coemar** presets (barring specific requests) a voltage of 240v.

The preset voltage is indicated on a sticker located on the base of the projector near the position of the voltage selector switch.

iWASH 575 EB may operate at either 50 or 60 Hz without any changes required.

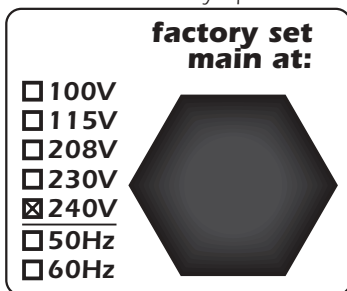

selecting an operating voltage different to the factory preset

It is possible to alter the operating voltage of the projector at any time. See section **15. Altering the operating voltage**
An error in voltage selection may cause serious damage to the projector.

6. Installation

installation

iWASH 575 EB may be either floor or ceiling mounted.

For floor mounting installations, the **iWASH 575 EB** is provided with four rubber mounting feet

For truss mounted installations **coemar** includes 2 cam-lock mounting devices (**A**).

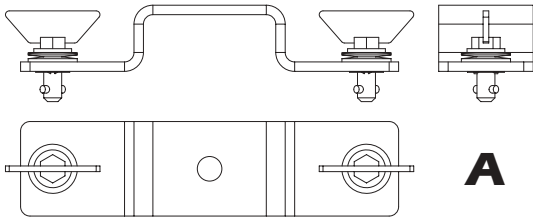

You may fit the cam-locks in 2 different positions on the base of the **iWASH 575 EB**. The cam-lock fittings are of the type which need a 1/4 turn. To be used correctly the fittings must be correctly fitted with some care.

Posizione 1 / Position 1

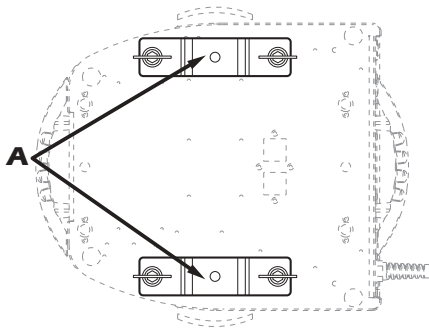

Posizione 2 / Position 2

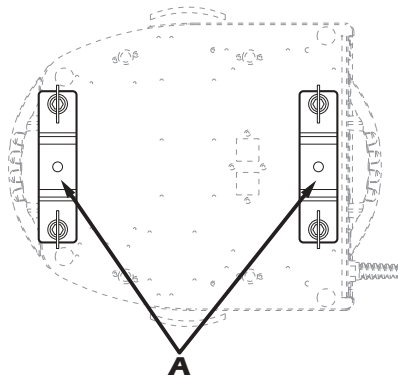

If suspending the units we recommend the use of an appropriate structure and suspension clamps able to sustain the weight of the unit.

Clamps may be fitted to the central position of the cam-lock fixtures.

Attention

Always use two clamps per projector

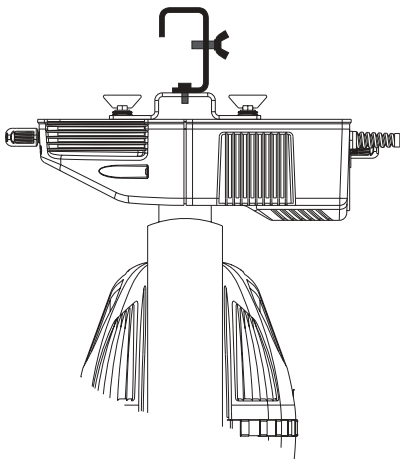

The structure from which the unit is hung should be of sufficient rating to hold the weight of the unit, as should any clamps used to hang the unit. The structure should also be sufficiently rigid so as not to move or shake whilst the **iWASH 575 EB** moves during its operation.

English

safety chains

We recommend the use of a safety chain fitted through the "B" slot of the **iWASH 575 EB** and to the suspension truss in order to avoid the fixture accidentally falling. If using an after-market safety chain not manufactured by **coemar**, ensure that it is of sufficient rating to hold the weight of the unit.

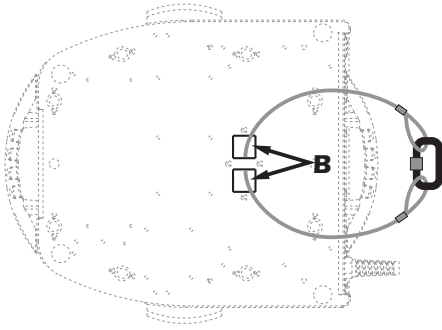

protection against liquids

The projector contains electric and electronic components that must not come into contact with water, oil, or any other liquid.

movement

The projector has a maximum movement of 360° in the base and 252° in the yoke; **DO NOT** place any obstructions in the path of the projector's movement.

risk of fire

Each fixture produces heat and must be installed in a well-ventilated position. The minimum recommended distance from flammable material is: 0.5m. Minimum distance from the object being illuminated is: 2 m.

forced ventilation

You will note that the projector features several air inlets and cooling fans, located at the rear of the projector and on the base. Under no circumstances should these be obstructed.

Obstruction of these cooling features may cause the fixture to overheat and may result in serious damage occurring.

ambient temperature

Never install the fixture in an enclosed area lacking sufficient air flow; the ambient temperature should not exceed 35°C.

7. Mains connection

cabling

The mains cable provided is thermally resistant, complying to the most recent international standards. It meets or exceeds VDE and IEC norms, IEC 331, IEC 332 3C, CEI 20 35.

NB: In case of cable replacement, similar cable with comparable thermal resistant qualities must be used exclusively (cable 3x1.5 \varnothing external 10 mm, rated 300/500V, tested to 2KV, operating temperature -40° +180°, **coemar** cod. CV5309).

Mains connection

iWASH 575 EB can operate at voltages from 208V-230V-240V at 50 or 60Hz (operating voltage and frequency can be selected as described in section 5 of this manual).

Prior to connecting the unit to your mains supply, ensure that the model in your possession correctly matches the mains supply available to you. For connection purposes, ensure your plug is of a suitable rating of 3,5 amps at 230V, 7 Amps at 115 V. Locate the mains cable which exits the base of the unit and connect as shown below:

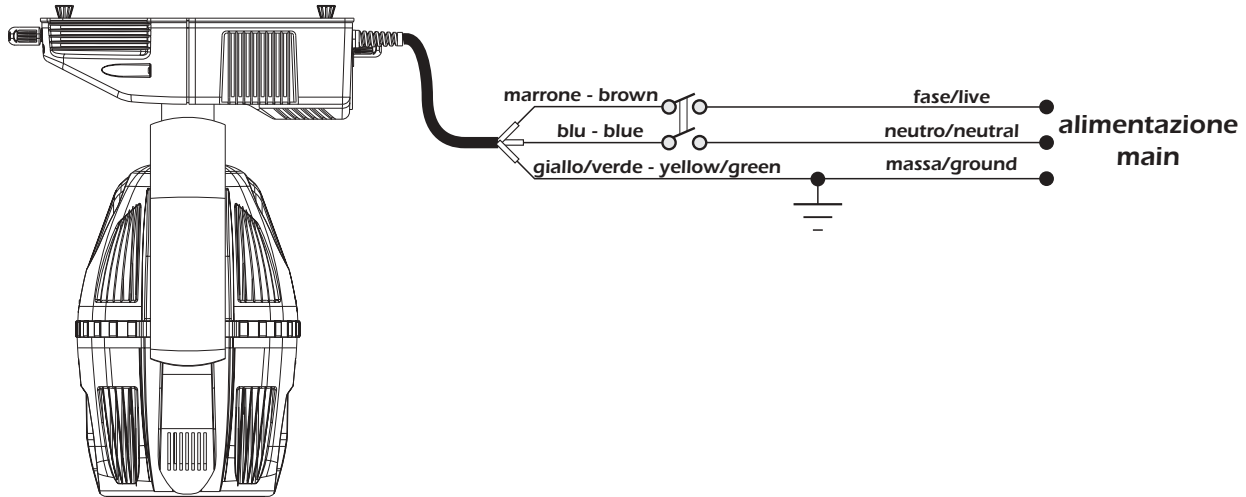

protection

The use of a thermal magnetic circuit breaker is recommended for each **iWASH 575 EB**.

A good earth connection is essential for the correct operation of the fixture. Strict adherence to regulatory norms is strongly recommended.

8. Signal connection

Control signal is digital, and is transmitted via two pair screened $\varnothing 0.5\text{mm}$ cable. Connection is serial, utilising XLR 3 male and female sockets located on the base of the **iWASH 575 EB**, labeled **DMX 512 In** and **OUT** (see diagram).

Pin connections conform to the international standard:

- pin 1= screening 0 volt
- pin 2= data -
- pin 3= data +

If using a controller which output signal via an XLR 5 (5 pin) socket, do not use pins 4 and 5, leaving them unconnected.

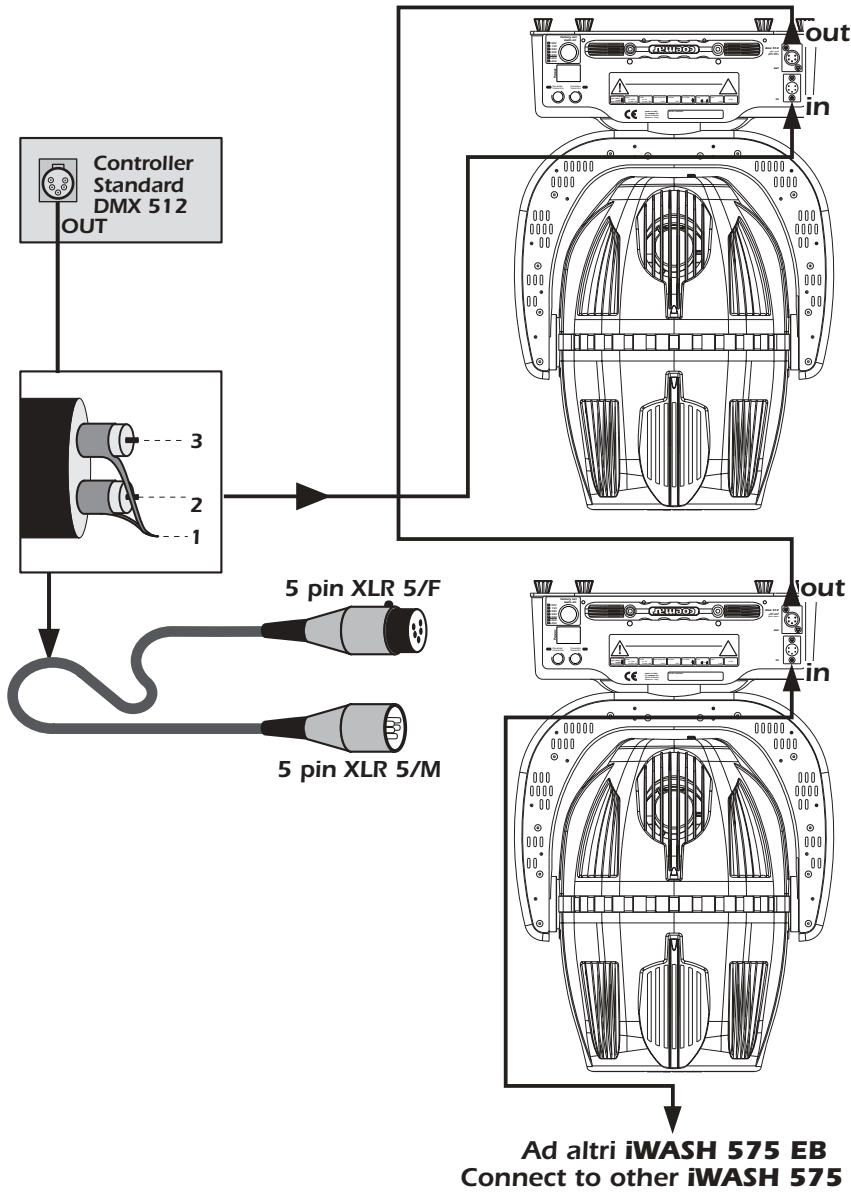

Ensure that all data conductors are isolated from one another and the metal housing of the connector.

Note: the housing of the cannon XLR 3 must be isolated.

9. Powering up

After having followed the preceding steps, turn on the DMX 512 controller which will be used to control the fixture. Following this, turn on the power to the projector, and turn on the projector's power switch. The projector will perform a reset function on all the internal and external motors. This will last some few seconds, after which it will be subject to the external signal from the controller.

Software version

Three groups of software operate within the system; some in the display microprocessor of the unit "D" and some in the master microprocessor "A" and "B". On powering up the display will briefly show the current versions of the installed software: For example, the **iWASH 575 EB** may show:

01.00 (display software "D" version 1.00.

A1.11 (master software "A" version 1.11.

DMX signal reception

After the display of software versions installed in the unit's microprocessors, the projector will reset and the display will be fixed on to show that **DMX 512** is being correctly received by the projector.

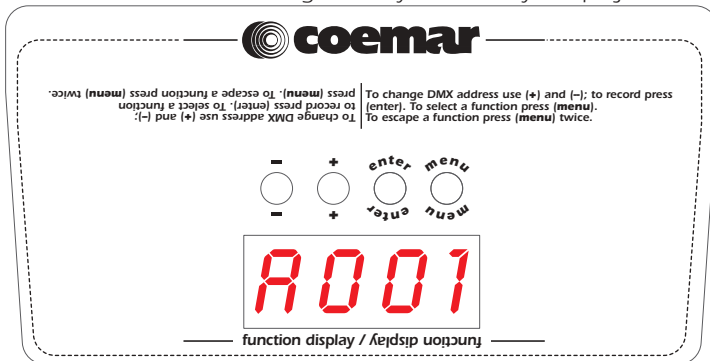

If the display flashes, the projector is not receiving signal. Check that the cabling is connected correctly and that the controller is operating properly.

powering up with no dmx signal connected

After the display of software versions installed in the unit's microprocessors, the projector will reset and the display will flash to indicate that there is no **DMX 512** signal being received.

10. DMX addressing

Each projector utilises **16** channels of DMX 512 signal for complete control. (see section **12. DMX 512 channel functions** for further information)

DMX addressing

To ensure that each projector accesses the correct signal, it is necessary to correctly address each fixture. Any number between 1 and 496 can be generated via the multifunction panel of the **iWASH 575 EB**.

This procedure must be carried out on every **iWASH 575 EB**.

When powered up initially, each projector will show **A001** which indicates **DMX address 1**; a projector thus addressed will respond to commands on channel **1** to **16** from **DMX 512 controller**. A second unit should be addressed as **17**, a third as **33** and so on until the final **iWASH 575 EB** has been addressed.

Altering DMX addresses

- 1) Press the **+** or **-** button until the display shows the **DMX** required, the characters in the display panel will flash to indicate that the selection is not stored in memory.

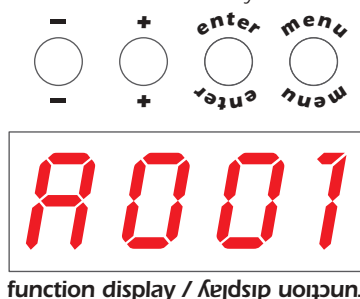

- 2) Press the **enter** button to confirm your selection; the display will stop flashing and the projector will now respond to the new DMX address.

- 3) To better understand the function of each channel, we refer you to section

12. DMX 512 channel functions

Important Note: Keeping the **+** or **-** button pressed will cause the display to alter at increased speed, allowing a faster selection to be effected.

11. Display panel functions

The display panel of the **iWASH 575 EB** shows all the functions available; it is possible to change some of those parameters and to add some functions.

Changing the setting made by coemar can vary the functions of the device so that it will not respond to the **DMX 512** controller used to control it. Carefully follow the instructions before applying any variations or selections.

NOTE: the symbol  shows which key has to be pushed to obtain the function desired.

11.1. Function settings (FUNC)

The projector allows the altering of several functions and select personalised settings.























































AD01

 menu

FUNC functions menu

The unit gives the possibility to vary some functions settings and to apply personalizations.

 enter

 +/-	PD IR pan movement inversion To reverse horizontal movement direction of the beam on DMX level variation.	 enter	 +/-	CW clockwise	 enter
			 +/-	CCW counter-clockwise	 enter
 +/-	TD IR tilt movement inversion To reverse vertical movement direction of the beam on DMX level variation.	 enter	 +/-	CW clockwise	 enter
			 +/-	CCW counter-clockwise	 enter
 +/-	OPTO optic sensor de-activation To deactivate the optic sensor function with return in position of the unit if accidentally knocked out of place.	 enter	 +/-	ON sensors activation	 enter
			 +/-	OFF sensors deactivation	 enter
 +/-	LAMP lamp control To disable on/off control of the lamp by DMX signal	 enter	 +/-	STRD switching on through DMX 512	 enter
			 +/-	ON lamp always on	 enter
 +/-	FANS fans control Fans status control through PCB (Strd) or fans always on (On).	 enter	 +/-	STRD fans speed control depending on external temperature and lamp status	 enter
			 +/-	ON fans always on	 enter
 +/-	DISP reverse display To reverse the display reading depending on mounting position (base or suspended)	 enter	 +/-	AA base downwards	 enter
			 +/-	BB reversed, base upwards	 enter
 +/-	LED display control To disable display visualisation.	 enter		OFF to switch the display off ( any keys to switch it on)	 enter
 +/-	RESE reset Reset function.	 enter		--- reset activation	
 +/-	DFSE default functions setting to set all the functions at the original values, but for the alignment operations and for the recorded programs.	 enter		SURE flashing	 enter
 +/-	DEMO demo program To see all the unit's functions to activated.	 enter		--- demo program activation	
 +/-	ZAP.E zap effect zap effect	 enter	 +/-	ON zap on	 enter
			 +/-	OFF zap off, disabled	 enter
 +/-	ID ID number setting To set the unit's ID number from 0(no ID, to 250).	 enter		1-250 numeric value	

inverted display

As indicated above, the **iWASH 575 EB** allows the display in the led display panel to be inverted for ease of use should the projector be operated with its base on the ground.

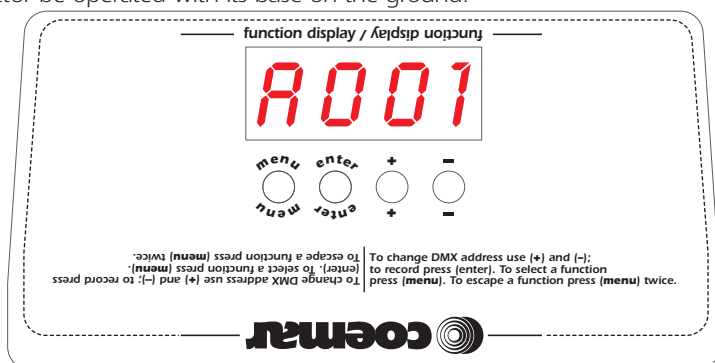

A001

menu

FUNC

+o-

DISP reverse display

To reverse the display reading depending on mounting position (base or suspended)

enter

+o-

AA

base downwards

enter

+o-

YY

reversed, base upwards

enter

English

11.2. Measure and test(MEAS)

The internal microprocessor of the **iWASH 575 EB** allows for several diagnostic and output parameters to be displayed. You may record, in this menu, the position in which the projector will come to rest when turned on with no dmx signal attached.

R001

menu

FUNC

+0-

MEAS

enter

TEST

test
function test

enter

PAN

pan movement

enter

0128/255

+0-

TILT

tilt movement

enter

0128/255

+0-

DIMM

dimmer activation

enter

0128/255

+0-

SHUT

shutter activation

enter

0128/255

+0-

EFF

test effect

enter

0128/255

+0-

ZOOM

test zoom

enter

0128/255

+0-

COLR

test rotation of colours

enter

0128/255

+0-

CYAN

test cyan

enter

0128/255

+0-

MAG

test magenta

enter

0128/255

+0-

YELL

test yellow

enter

0128/255

+0-

ZAP.E

zap effect activation (the function depends on shutter level, as per function with DMX 512 signal)

enter

0128/255

+0-

STOR

to record the position of the unit and of its internal components. If DMX signal is not applied, the recorded setting will appear at the end of reset operation when the unit is switched on.

enter

SURE

flashing

+0-

to confirm

TEMP

temperature

to measure the internal temperature in C°

enter

58C

temperature measurement

+0-

VOLT

tensione di alimentazione

to measure DC mains voltage in volts. The value is measured at rectifier bridge output. Values lower than 26V and higher than 36V are anomalous.

enter

30.0V

voltage measurement

+0-

DMIN

DMX value on each channel

reading of DMX value (0/255), received by each of the 22 channels on DMX 512 line.

enter

CH01

from channel 1

enter

10

DMX value reading

+0-

CH16

to channel 16

enter

255

DMX value reading

+0-

RATE

DMX rate

reading of DMX 512 signal value.

enter

20

value reading

+0-

HOUR

working time

working time (in hours)

enter

LIFE

lamp life after last reset

N.B.: reset the **LIFE** value when changing the lamp

enter

10

value reading

+0-

LIFS

life of all lamps used on the unit

enter

589

value reading

+0-

UNIT

projector life

enter

1230

value reading

11.3. Quick guide to menu navigation

For your convenience, the following is a guide to navigating the menu system of the projector.

A001

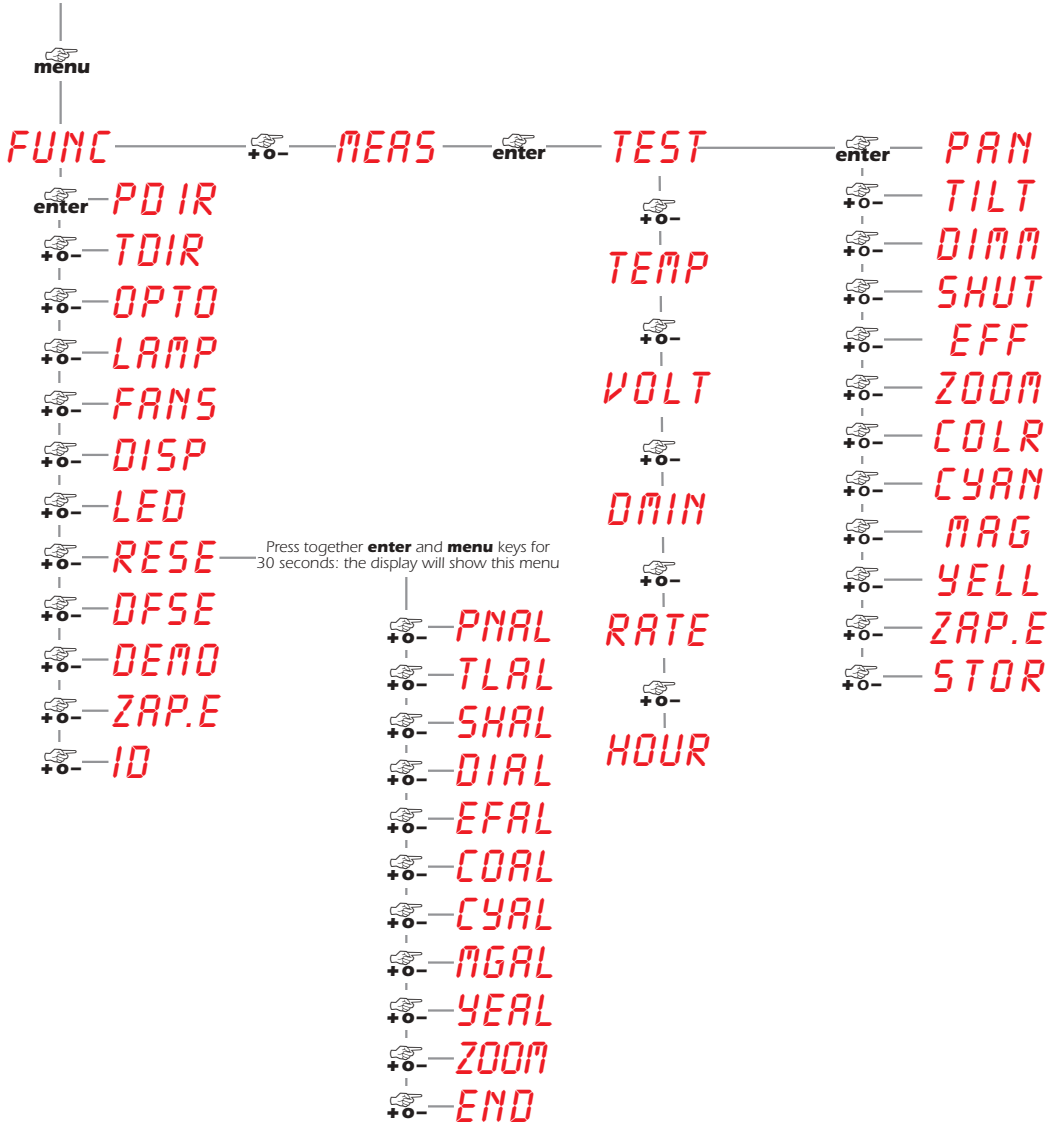

11.4. Rapid scrolling

Via the **iWASH 575 EB** display, it is possible to rapidly scroll through the various numbers displayed in the menu which apply to the following 3 uses:

- 1) Pressing down and holding the + or - buttons will cause the numbers to scroll more quickly than by simply pressing buttons repeatedly
- 2) Pressing down the + button and then the - button and holding them down simultaneously will cause the numbers to jump to the highest possible value available in the particular function.
- 3) Pressing down the - button and then the + button and holding them down simultaneously will cause the numbers to jump to the lowest possible value available in the particular function.

12. DMX 512 channel functions

If you have correctly followed all the steps described up to this point, your **DMX 512** controller will allow you complete control of all the functions of the **iWASH 575 EB** as described in the following table:

channel	function	type of control	effect	decimal
1	x axis, base movement (pan)	proportional	control of the movement of the beam of light by proportional rotation of the pan motor of the fixture at the base	0-255
2	x axis, fine base movement (pan)	proportional	fine control of the movement of the beam of light by proportional rotation of the pan motor of the fixture at the base	0-255
3	y axis, yoke movement (tilt)	proportional	control of the movement of the beam of light by proportional rotation of the tilt motor of the fixture at the yoke	0-255
4	y axis, fine yoke movement (tilt)	proportional	fine control of the movement of the beam of light by proportional rotation of the tilt motor of the fixture at the yoke	0-255
5	movement speed	step	standard (fast)	0-10
		step	ultra fast movement (ideal for positioning during programming)	11-25
		proportional	vector mode - fast to slow-	26-127
		proportional	Tracking mode (from fast to slow)	128-247
		step	Tracking mode (slow)	248-255
6	dimmer	step	closed	0-7
		proportional	from closed to open	8-255
7	blackout, strobe zap effect, depending upon channel 15	step	blackout closed (zap off)	0-9
		proportional	synchronised strobing effect, from slow to fast (shutter / zap or combination, selectable via channel 15)	10-66
		step	blackout open (zap off)	67-68
		proportional	sequenced pulse effect, slow closing, fast opening (Speed variable from slow to fast) / (shutter / zap or combination, selectable via channel 15)	69-125
		step	blackout open (zap off)	126-127
		proportional	sequenced pulse effect, slow closing, fast opening (Speed variable from fast to slow) / (shutter / zap or combination, selectable via channel 15)	128-184
		step	blackout open (zap off)	185-187
8	beam angle	step	spot	0-9
		proportional	from narrow (spot) to wide (Flood)	10-255
9	conversion filter and "par" effect	step	no filter	0-9
		proportional	oval beam (par effect) rotatable 0 to 180°	10-230
		step	CTO conversion filter	231-255
10	colour wheel	step	open white	0-7
		step or proportional selectable via channel 14	colour 1	8-27
			colour 2	28-47
			colour 3	48-67
			colour 4	68-87
			colour 5	88-107
			colour 6	108-127
proportional	rainbow effect in a clockwise direction from fast to slow	128-190		
step	no rotation	191-192		
proportional	rainbow effect in an anti-clockwise direction from slow to fast	193-255		
11	cyan	step	open white, no colour	0-9
		proportional	proportional control of the cyan colour from white to full cyan	10-255
12	magenta	step	open white, no colour	0-9
		proportional	proportional control of the magenta colour from white to full magenta	10-255
13	yellow	step	open white, no colour	0-9
		proportional	proportional control of the yellow colour from white to full yellow	10-255
14	colour positioning mode change the function of channel 10	step	the colours in the colour wheel step to the centre of the optical path	0-125
		step	the positioning of colours becomes proportional	126-255
15	zap effect	step	no effect	0-10
		step	zap effect synchronised with the strobe effect	11-30
		proportional	zap effect, lamp flicker frequency adjustment on channel 7	31-249
		step	Black-out of the beam of light during PAN/TILT movement of the fixture or whilst colours on the colour wheel are being changed	250-255
16	lamp on/off and motor resetting	step	park, no function	0-10
		step	lamp off	11-29
		step	pan and tilt reset (once only)	30-65
		step	reset of all the motors with the exception of the dimmer, pan and tilt (once only)	66-100
		step	reset of all the motors with the exception of the dimmer (once only)	101-135
		step	reset of all the motors (once only)	136-170
		step	fan forced at maximum speed	171-249
step	lamp on, silent fans (if the internal temperature is acceptably low)	250-255		

lamp off via DMX may be inhibited via settings on the fixture's display panel

N.B. turning off the lamp and all the reset functions are delayed by 6 seconds to prevent accidental activation

N.B. the lamp on/off function can only be effected if an opposite level is set

13. Aligning the lamp in the optical path

Aligning the lamp in the optical system is achieved via the 3 adjusters at the rear of the projector. This procedure should be undertaken to properly align the lamp in the optical system and to avoid the possible overheating of the internal components due to the incorrect focusing of the beam onto components not intended to be exposed to this.

alignment procedure

Alignment is effected via the 3 adjusters **A**, **B** and **C** operating in conjunction with each other. The lamp should be on, black-out and dimmer fully open, and no colour filters inserted.

If the lamp is not correctly aligned, a hot-spot will be noticeable. This is a function of the lamp's positioning. Use the two adjusters (**B** and **C**) to bring the hot-spot to the centre of the beam. Use the third adjuster (**A**) to flatten the beam to maximum uniformity.

vertical adjustment

Screw (**C**) acts on a lever and spring assembly to position the lamp via a vertical movement within the reflector; rotate it until correct positioning is achieved.

horizontal adjustment

Screw (**B**) acts on a lever and spring assembly to position the lamp via a horizontal movement within the reflector; rotate it until correct positioning is achieved.

axial adjustment

Screw (**A**) moves the entire lamp assembly axially within the unit; rotate it until correct positioning is achieved, resulting in a flat, even beam.

NB: It is extremely important that a uniform beam spread is achieved. Avoid creating a hot-spot in the beam as this may cause overheating of internal components.

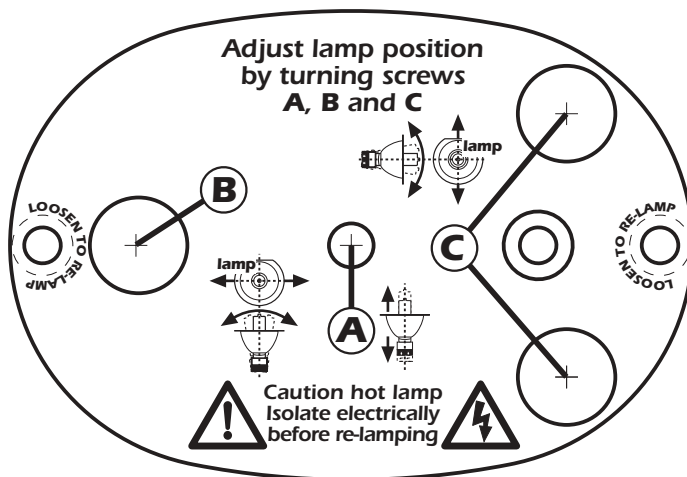

14. Turning on the iWASH 575 EB without movement

This function may be useful should you need to power up the **iWASH 575 EB** inside its roadcase or for any other reason where you may wish to power up the unit without it moving.

1) Power up the projector whilst simultaneously pressing the **enter**, **menu** and **-** buttons.

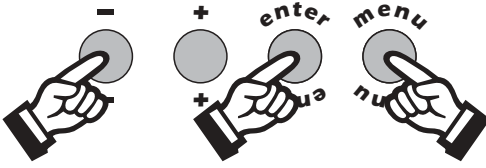

the projector will perform the usual reset functions on every motor barring the pan and tilt motor, which will remain static throughout the reset procedure..

2) You may at this point alter a DMX address, or any other menu-based parameter without projector articulated movement.

3) To resume normal **iWASH 575 EB** functioning, you must turn the projector of and on again via the **power** button.

15. Resetting the counter

The electronic counter should be reset to zero hours every time the lamp is changed in order to provide accurate information about lamp life

Power up the **iWASH 575 EB** whilst simultaneously holding the **+** and **-** buttons, the fixture will start up with the counter reset.

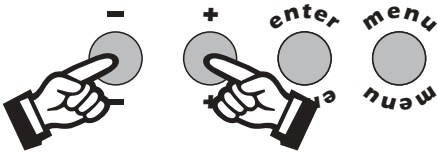

The projector will have effected a reset of the **LIFE** counter

To verify that the counter reset has been undertaken:

1) Press the **menu** button, the projector will show **MODE**

2) Press the **+** or **-** button until **MERS** is displayed

3) Press the **enter** button

4) Press the **+** or **-** button until **HOUR** (for hour) is displayed.

5) Press the **enter** button

6) Press the **+** or **-** button until **LIFE** (lamp life) is displayed.

7) Press the **enter** button; the display will show **0000** confirming that the counter has been reset.

N.B. You may also verify that the other counters **LIFS** (cumulative lamp life for all lamps installed) and **UNIT** (number of hours of fixture operation) have remained unaltered.

16. Automatic realignment

An internal 4 point encoder system allows the **iWASH 575 EB** to return to its correct position in case the unit is accidentally knocked out of alignment whilst operating. This is particularly useful if the projector is to be mounted on the floor in a position where the performer or artist may accidentally bump the unit.



NOTE: this function is able to be disabled (Display panel functions **OPTO OFF**).

17. Opening up the projector

By removing the casing, complete access is available to the internals of the projector.

Attention

Always remove mains power prior to accessing the internal components of the projector.

1) Use a screwdriver to remove the screws which affix the front and rear housings.



2) Lift the housing to gain access to the internals of the fixture.



18. Altering the operating voltage (reserved for technical personnel)

If the factory preset operating voltage and frequency do not correspond to those in use in your country of operation, you may alter the settings as described in the following paragraphs.

Incorrect selection of operating voltage and frequency will seriously compromise the functioning of the projector.

18.1. Selecting the transformer voltage

1) Loosen the screws on the cover of the base of the unit, as shown in the diagram below, using a Philips head screwdriver, thereby removing the cover completely and allowing access to the internal components of the base of the **iWASH 575 EB**.

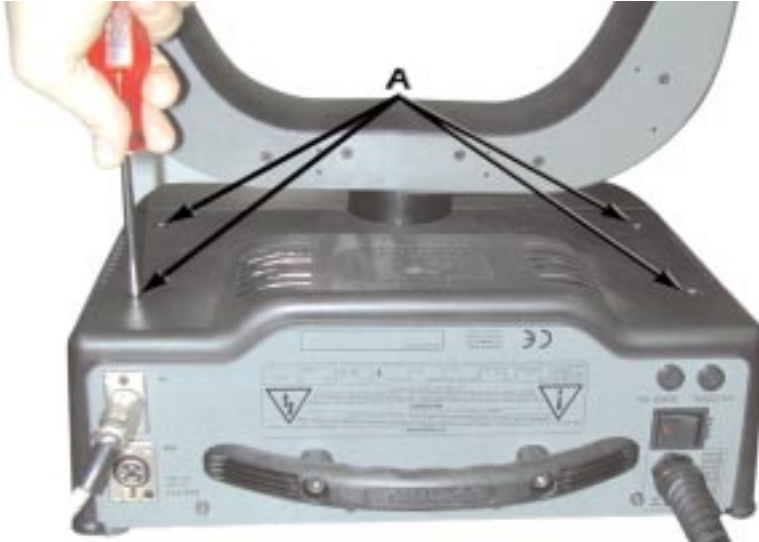

- 2) Locate the autotransformer in the base of the unit.
- 3) Select a voltage from amongst 100, 115, 208, 230 and 240V by removing cable n° 5 and moving it to the required voltage. To determine which is the correct tap, refer to the sticker located on the autotransformer. Cable number 3 should not be moved under any circumstances.
- 4) If the operating voltage selected is 115V replace the 5 Amps T, and the 2 Amps T fuses, suitable for 208/230/240 V, operation with ones rated respectively at 12 Amps T and 3 Amps T in the fuse holder in the base of the projector and vice versa (see label). Replacement fuses of suitable ratings were provided in the packaging of your fixture with this manual.

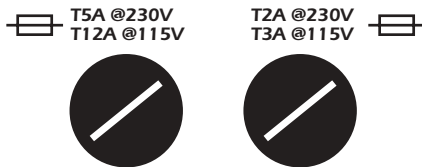

6) Note on the sticker on the outside of the **iWASH 575 EB** the new voltage which you have selected.

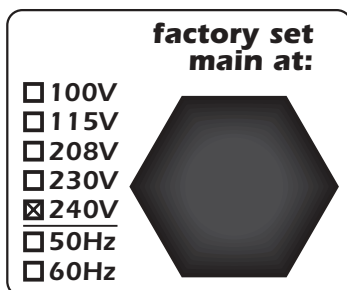

- 3) Close up the base with the housing covers as they were originally.
- 4) Note on the sticker on the outside of the **iWASH 575 EB** the new voltage which you have selected. (as shown in the diagram)

19. Thermal protection

A thermal sensor in the body of the **iWASH 575 EB** protects the unit against overheating.

The thermal sensor removes power from the lamp should the ambient temperature exceed the set maximum or if there is a lack of air flow or there is a fan malfunction.

20. Lamp circuit protection

Two timers operate simultaneously within the projector to protect the lamp ignitor and power supply against prolonged operation in non-ideal conditions.

A protection device, inside the electronic ballast, impedes attempts to power up the lamp for more than 3 seconds if the lamp has failed to ignite. The device will automatically attempt to restart the lamp for a further 3 seconds in every minute.

A software timer reattempts lamp ignition for a period of 20 seconds in every minute for up to 8 minutes; then it preserves the lamp circuit by not allowing high voltage to the lamp (assuming the lamp to have passed its useful life).

The display will show **LAER** (lamp circuit error) each time an unsuccessful attempt is made to turn on the lamp

NOTE: it is important to remove power from the fixture if the lamp has reached the end of its life and to replace the lamp.

21. Maintenance

Whilst every possible precaution has been taken to ensure the trouble-free operation of your **iWASH 575 EB**, the following periodic maintenance is highly recommended. All maintenance should be effected with the power to the unit switched off

Attention

Disconnect mains power prior to removing the projector housing.

To gain access to the internals of the unit refer to section **17. Opening up the projector.**

periodic cleaning lenses and reflectors

Even a fine layer of dust can reduce the luminous output substantially. Regularly clean all lenses and the reflector using a soft cotton cloth, dampened with a specialist lens cleaning solution.

fans and air passages

The fans and air passages must be cleaned approximately every 6 weeks; the period for this periodic cleaning will depend, of course, upon the conditions in which the projector is operating. Suitable instruments for performing this type of maintenance are a brush and a common vacuum cleaner or an air compressor.

periodic maintenance lamp

The lamp should be replaced if there is any observable damage or deformation due to heat. This will avoid the danger of the lamp exploding.

mechanicals

Periodically check all mechanical devices for wear and tear; gears, guides, belts, etc., replacing them if necessary. Periodically check the lubrication of all components, particularly the parts subject to high temperatures. If necessary, lubricate with suitable lubricant, available from your **coemar** distributor.

electrical components

Check all electrical components for correct earthing and proper attachment of all connectors, refastening if necessary.

fuse replacement

Locate the fuse, which protects the lamp and electronics, in the base of the **iWASH 575 EB**.

Using a multimeter, test the condition of the fuse, replacing it with one of equivalent type if necessary.

22. Electronic motor alignment

Attention!
This section is reserved only for technical and specialist personnel.

The display panel of the **iwASH 575 EB** allows for the electronic alignment of the projector's motors in the optical system. This procedure is performed by **coemar** at the factory. It may be useful to perform this procedure in the case of internal components being replaced.

Altering the factory settings may radically alter the functioning of the projector. Carefully read all of the following prior to attempting any changes.

electronic calibration

Attention!
Electronic calibration is only possible if the projector is receiving DMX 512 signal.

- 1) Press the **menu** button.
- 2) Press the **+** or **-** button until the display shows **RESE** (for reset).
- 3) Press the **enter** and **menu** buttons simultaneously and hold for at least **30"**. The motors of the unit will perform a reset and the display will show **----** for some few seconds, indicating that you have entered the electronic calibration mode:

A001 **menu** **+/-** **FUNC** **+/-** **RESE**



simultaneously
+ **-** **0128**

NOTE:
 To speed up the alignment procedure, press the **+** and **-** keys simultaneously to cause the display to jump straight to 128.

23. Error messages

MBER:	<p>COMMUNICATION Error This message indicates that the motherboard within the unit is not communicating properly with the control source. Check the connectors located on both boards.</p>
OPER:	<p>PAN ENCODER Error This message indicates that there is a problem with the PAN encoders. Check the sensors on the encoder wheel located near the pan movement motor, as well as the relevant cabling.</p>
OTER:	<p>TILT ENCODER Error This message indicates that there is a problem with the TILT encoder located on the fixture yoke. Check the sensors on the encoder wheel located near the pan movement motor, as well as the relevant cabling.</p>
LAER:	<p>LAMP Error The lamp has turned off unexpectedly, without any signal from the controller to do so. The system may have exceeded the allowable number of attempts to ignite the lamp (10) after which number the system is designed to protect ignitor, cabling and the lampholder by reducing the incidence of lamp ignition voltages to these components. Check and eventually replace the lamp if it is faulty, damaged, or has exceeded its lamp life.</p>
EPER:	<p>EEPROM Error The EEPROM is either defective or absent; refer to your coemar service centre for a replacement component.</p>
OTER:	<p>DATA Error The initial parameter settings are incorrect or corrupt; the projector has reloaded its factory default settings. Turn the projector off and on again. Should the error reoccur, refer the unit to your authorised coemar service centre to have the EEPROM check and possibly replaced.</p>
ADER:	<p>DMX addressing Error The projector is not receiving all DMX channels needed to operate correctly. Check the DMX address indicated on the display and the channel numbers being outputted from the controller. Note that not all controllers will output all 512 channels.</p>
ADER:	<p>RESET circuit Error in colour wheel and effects Check the cabling and the respective RESET sensors</p>
LRER:	<p>RESET circuit Error in zoom lens Check the cabling and the respective RESET sensors</p>
COER:	<p>Position Error in colour wheel Check the functioning and correct positioning of the magnetic sensor of the colour wheel</p>
EFER:	<p>Position Error in effects wheel (CTO and beam sizing filters) Check the functioning and correct positioning of the magnetic sensor of the effects wheel</p>
ZOER:	<p>Position Error in the zoom lens Check the functioning and correct positioning of the magnetic sensor of the zoom lens</p>
ER20 ÷ ER99:	<p>SYSTEM Error Turn the unit off and on again. If the error persists, contact your authorised coemar service centre.</p>
HEAT:	<p>LAMP OVERHEAT Indicator The projector is attempting to ignite a lamp, which is still too hot to strike. Wait until the lamp has cooled further and then attempt to reignite the lamp.</p>

24. Spare parts

All the components of the **iWASH 575 EB** are available as replacement spares from your authorised **coemar** sales agent. Accurate description of the fixture, model number, and type will assist us in providing for your requirements in an efficient and effective manner.