



## LAMPO lighting designers

46042 Castel Goffredo - Mantova - Italy

Via Portogallo, 4

tel +39 0376 770869 fax +39 0376 780947

[www.lamposrl.it](http://www.lamposrl.it)

e-mail [info@lamposrl](mailto:info@lamposrl) [sales@lamposrl](mailto:sales@lamposrl)

[tech@lamposrl](mailto:tech@lamposrl) [exp@lamposrl](mailto:exp@lamposrl)

**ITALIANO**

## CEILING LED **rgb**



## IP40 LED colour changer

### MANUALE D' USO versione 1.0

*Questo manuale è da considerarsi parte integrante del proiettore.*

**PRIMA DI CONNETTERE E METTERE IN FUNZIONE IL PROIETTORE, E' IMPORTANTE LEGGERE ATTENTAMENTE QUANTO RIPORTATO NEL SEGUENTE MANUALE.**

**L'INSTALLAZIONE, LA MANUTENZIONE E L'UTILIZZO DI QUESTO PROIETTORE DEVONO ESSERE ESEGUITE SOLO DA PERSONALE QUALIFICATO, NEL RISPETTO DI TUTTE LE NORME DI SICUREZZA.**

**PRIMA DI EFFETTUARE IL COLLEGAMENTO ALLA RETE ELETTRICA, ASSICURATEVI CHE I VALORI DI FREQUENZA E DI TENSIONE SIANO CONFORMI A QUANTO INDICATO NEL MANUALE.**

**PER QUALUNQUE DUBBIO CONTATTATE IL VOSTRO RIVENDITORE OPPURE INVIATE UNA E-MAIL A:**

**tech@lamposrl.it**

**IP40** SOLIDI: Protetto contro i corpi superiori a 1mm  
LIQUIDI: Non protetto



Istallabile direttamente su superfici normalmente infiammabili



Distanza minima dall'oggetto da illuminare (0,3 metri)

**ta 30 °C** Temperatura ambiente massima (per interni con normale circolazione d'aria)



Connettere ad una rete elettrica provvista di un efficiente sistema di messa a terra ( EN60598-1 – Apparecchio in classe I )

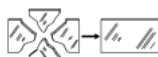

Sostituire gli schermi se rotti o deformati

## **Indice**

<b>Dimensioni e peso</b> .....	<b>pag. 2</b>
<b>Dati tecnici</b> .....	<b>pag. 2</b>
<b>Imballo</b> .....	<b>pag. 2</b>
<b>Condizioni di funzionamento</b> .....	<b>pag. 2</b>
<b>Istallazione</b> .....	<b>pag. 3</b>
<b>Collegamento proiettore - alimentatore</b> .....	<b>pag. 3</b>
<b>Dati illuminotecnici</b> .....	<b>pag. 4</b>
<b>Alimentazione elettrica</b> .....	<b>pag. 5</b>
<b>Esempi di collegamento</b> .....	<b>pag. 6</b>
<b>Cavo di segnale DMX</b> .....	<b>pag. 6</b>
<b>Interfaccia utente</b> .....	<b>pag. 8</b>
<b>Specifiche DMX</b> .....	<b>pag. 8</b>
<b>Modalità di funzionamento</b> .....	<b>pag. 9</b>
<b>Tabelle indirizzi MDX</b> .....	<b>pag. 12</b>
<b>Parti di ricambio</b> .....	<b>pag. 16</b>

## Dimensioni e peso

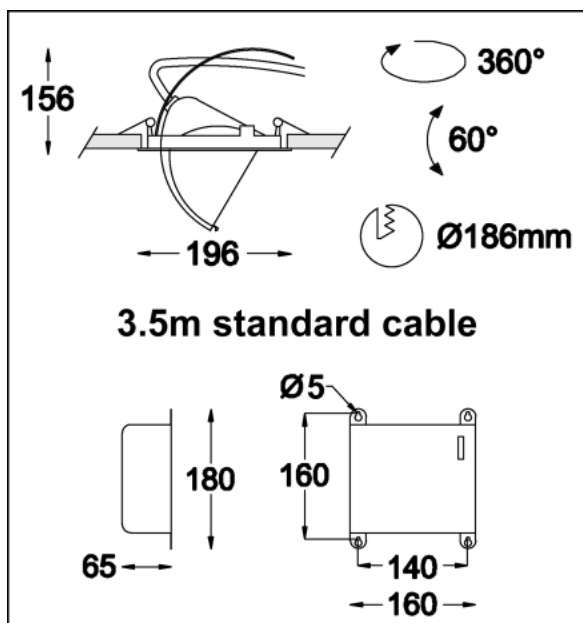

## Dati tecnici

- Corpo in alluminio, senza ventole
- Grado di protezione IP40
- Vetro di protezione diffusore (STANDARD)
- Vetro di protezione trasparente (su richiesta)
  
- Valori di tensione ammessi in entrata: da 195 a 265 Vac
- Frequenza di rete: 50 - 60 Hz
- Rifasamento a controllo elettronico, 0,95
- Controllo dei led in corrente
- Consumo Massimo: 22W ( Quando tutti i led sono accesi alla massima potenza)
  
- Controllo da centralina DMX
- Controllo in automatico da proiettore
- Controllo in automatico da telecomando (OPTIONAL AS148)

## **ATTENZIONE!!!**

**Collegare il proiettore Ceiling LED RGB solo alla scatola d'alimentazione dedicata.  
Non modificare il cavo che esce dal proiettore (3.5 metri con connettore) e non aggiungere prolunghe.**

## Imballo

Il proiettore, nel suo imballo originale, sigillato dal costruttore, può stare in zone umide con temperature fra  $-10^{\circ}\text{C}$  e  $+50^{\circ}\text{C}$ . Fare attenzione a non danneggiare il proiettore mentre viene tolto l'imballo.

## Condizioni di funzionamento

Il proiettore è stato studiato per funzionare in ambienti interni, con una temperatura in aria, compresa fra  $0^{\circ}$  e  $30^{\circ}\text{C}$  con un livello di umidità compresa fra 30 e 90%.

Una volta scelto il luogo di installazione, verificare che il proiettore non sia esposto a temperature troppo elevate.

La durata dei LED è legata alla temperatura, se il proiettore viene installato in un luogo caldo, la vita dei LED si accorcia.

## **Istallazione**

Il proiettore è predisposto per per l'istallazione all'interno di controsoffitti o strutture simili.

E' necessario praticare un foro con diametro 186mm (da 184 a 188) e fissare il proiettore all'interno del foro.

Delle molle permetteranno al proiettore di rimanere ancorato alla struttura.

La scatola di alimentazione non può essere fissata a più di 3.5m dal proiettore (il proiettore è dotato di un cavo speciale, lungo 3,5 metri, già terminato con connettore).

La scatola ha quattro fori di fissaggio, con interassi 160x140mm, del diametro da 5mm.



## **Collegamento proiettore - alimentatore**

Collegare il proiettore all'alimentatore, tramite il cavo che esce dal proiettore e il connettore predisposto.

Non modificare in alcun modo il cavo in uscita dal proiettore e non usare prolunghe, la lunghezza del cavo è 3.5metri, va collegato direttamente sul connettore della scatola d'alimentazione (LED).



## Dati illuminotecnici

- 18 LED da 1.2W LUXEON by Lumiled ad alta potenza
- Durata superiore a 10 anni (uso continuo)
- Sistema di miscelazione dei colori R.G.B.
- Regolazione intensità luminosa indipendente fra Rosso, Verde, Blu

All'interno del proiettore ci possono essere tre tipi di ottiche standard:

- Faro con lenti a 12° (AS 136)
- Faro con lenti a 30° (AS 137)
- Faro con sistema a 110° (AS138)
- Vetro di protezione anteriore:  
Trasparente (non modifica il fascio)  
Sabbaiato (funziona da diffusore e aumenta l'angolo di proiezione, solo per lenti 12° e 30°)

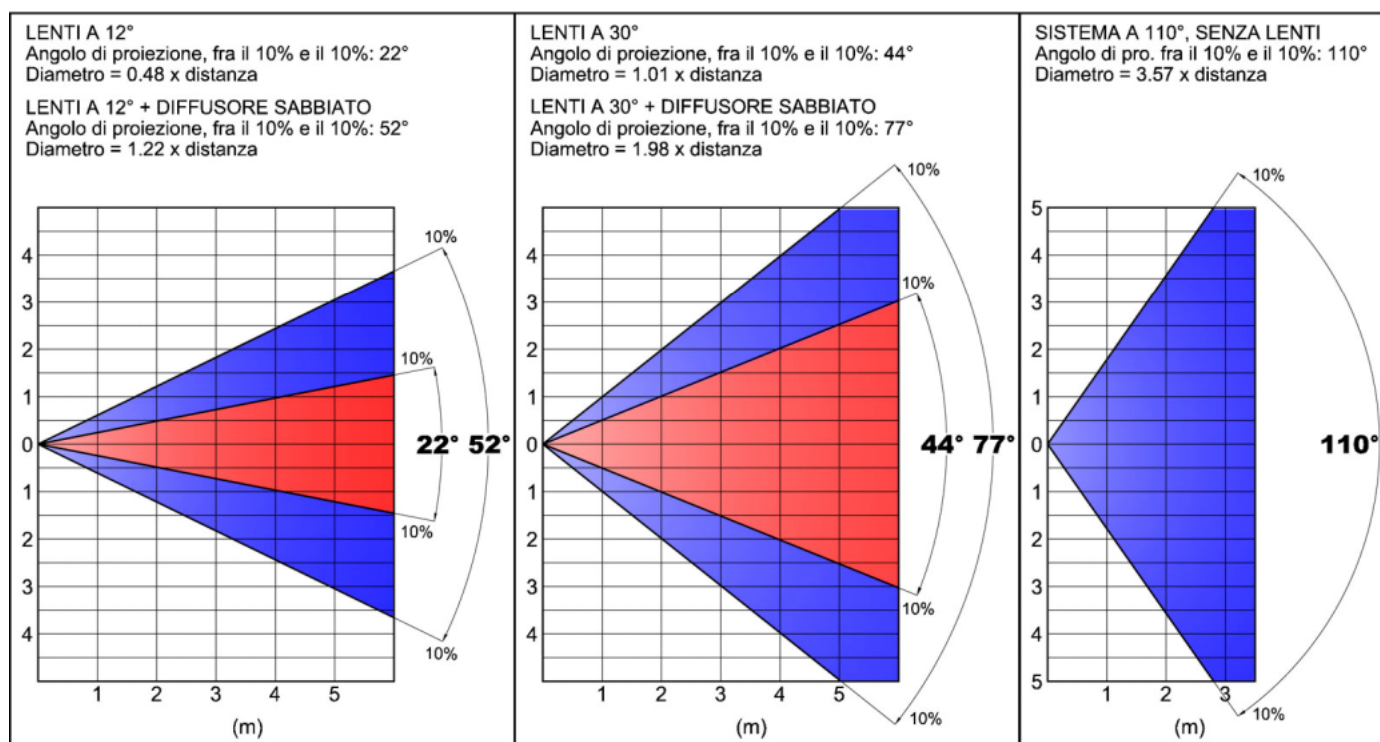

	22°	52°	44°	77°	110°	Distanza TEST <b>2</b> metri
ROSSO	954	116	353	80	27	
VERDE	1049	137	389	94	30	
BLU	445	65	165	45	13	
GIALLO	1907	290	706	200	55	
CIANO	1399	198	518	137	40	
MAGENTA	1271	178	471	122	37	
BIANCO	2162	355	800	245	62	
LUX						

	22°	52°	44°	77°	110°	Distanza TEST <b>3</b> metri
ROSSO	424	52	157	36	12	
VERDE	466	61	173	42	13	
BLU	198	29	73	20	6	
GIALLO	848	129	314	89	24	
CIANO	622	88	230	61	18	
MAGENTA	565	79	209	54	16	
BIANCO	961	158	356	109	28	
LUX						

## Alimentazione elettrica

Prima di effettuare qualsiasi operazione, togliere tensione all'impianto elettrico.

Per connettere l'apparecchio, seguire la tabella e i disegni riportanti i colori dei conduttori e la loro posizione.

PIN	SYMBOL	EC	US	UK
phase	L	brown	yellow/c	red
neutral	N	blue	silver	black
ground	$\equiv$	yellow/green	green	green

Non alimentare il proiettore da circuiti dimmer.

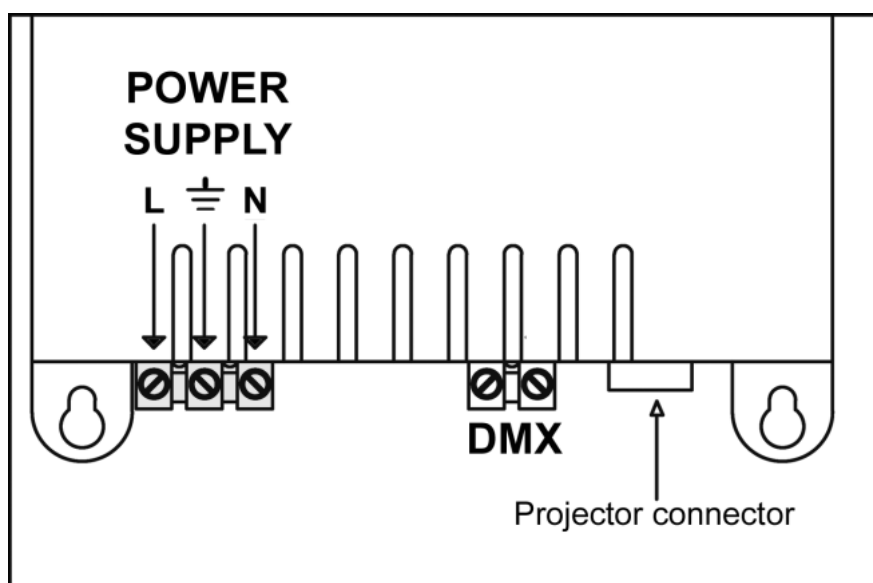

Se siete in dubbio, consultate un elettricista qualificato.

Il proiettore può essere alimentato con tensione compresa fra 195Vac e 265Vac (50 o 60 Hz). Verificare il sistema elettrico prima di una installazione.

Il proiettore è completamente a massa, è necessario il collegamento a terra.

Protegete il sistema elettrico con interruttori differenziali ad alta sensibilità, esempio 30mA.

## Esempi di collegamento

Se i proiettori vengono fatti funzionare in automatico (modalità 2, 3, 4, 5) non serve nessun cavo di segnale.

Se i proiettori vengono comandati da un DMX controller o da Led controller, (modalità 1), bisogna collegare i proiettori fra loro, tramite il cavo di segnale DMX, seguendo le indicazioni inserite nel manuale.

Il segnale DMX è generato da un controller DMX, il cavo di segnale entra ed esce dai proiettori fino all'ultimo. I proiettori eseguono le stesse scene se il loro indirizzo DMX è uguale (in fabbrica viene impostato 1) oppure sono comandati singolarmente se hanno gli indirizzi DMX diversi fra loro (ogni proiettore occupa 8 canali DMX):

**Proiettore 1: DMX address 1    Proiettore 2: DMX address 9    Proiettore 3: DMX address 17.....**

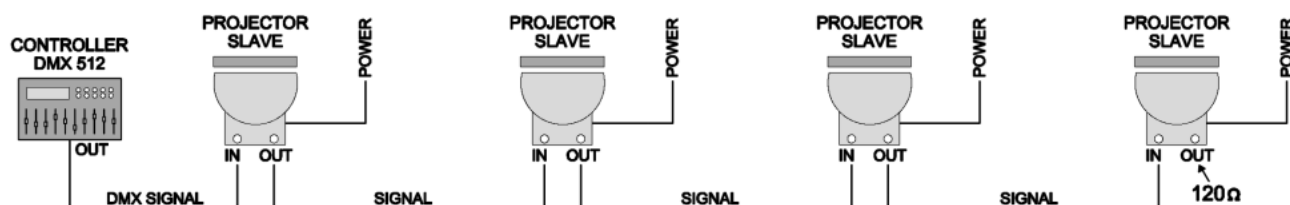

L'alimentazione elettrica (POWER) può provenire da sorgenti diverse, se un proiettore viene acceso successivamente, riceve il segnale DMX e si mette a funzionare come gli altri proiettori.

Se non viene acceso il DMX controller, i proiettori generano luce bianca (tutti i led si accendono).

Con questo tipo di proiettore, non è possibile la modalità MASTER/SLAVE, un proiettore non può comandare altri proiettori.

## Cavo di segnale DMX

Utilizzare solo cavi schermati con conduttori twistati (attorcigliati) seguendo le specifiche EIA485 (RS485), con bassa capacità e impedenza compresa fra 82 e 120 ohm.

I normali cavi per l'audio non garantiscono una buona efficienza, sono quindi sconsigliati.

Si consiglia di seguire gli esempi nelle tabelle per avere un riferimento sulla tipologia di cavi da utilizzare

### **Cavi con una coppia di conduttori**

Marca	Cod.	AWG	Impedenza ohm
BELDEN	1162A	20	100
BELDEN	8227	20	100
BELDEN	89207	20	100
ALPHA	9109	20	100
ALPHA	9817	20	100
ALPHA	9818	20	100

### **Cavi con 2 coppie di conduttori**

Marca	Cod.	AWG	Impedenza ohm
BELDEN	8102	24	100
BELDEN	8162	24	100
BELDEN	89696	22	100
PROPLEX	PC224P	22	110
PROPLEX	PC224T	22	110

La sezione dei conduttori consigliata è 26 AWG o superiore.

E' consigliabile:

- Non inserire più di 32 proiettori sulla stessa linea Dmx
- Non superare la lunghezza massima di 150m di cavo (con cavi di bassa qualità)
- Non superare la lunghezza massima di 300m di cavo (con cavi di buona qualità)

Generalmente dalle centraline DMX (controller) c'è una sola uscita di segnale, se vi sono più i 32 proiettori è necessario installare nelle immediate vicinanze del controller uno SPLITTER di segnale, che duplica il segnale su due o più linee.

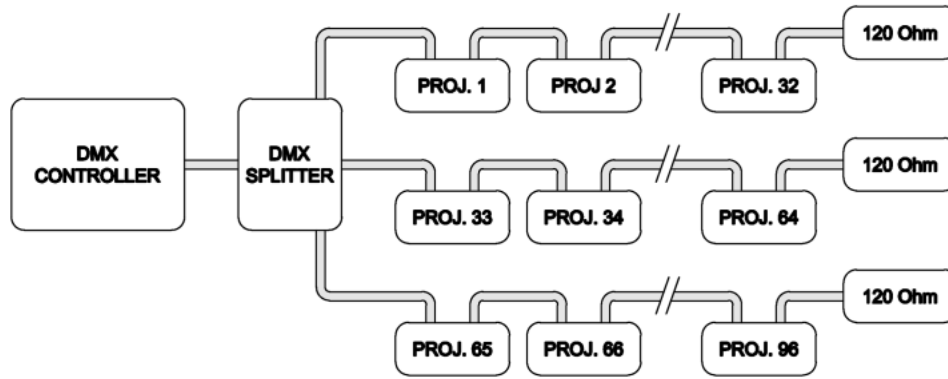

Se la lunghezza del cavo di segnale è troppo elevata bisogna installare un AMPLIFICATORE sulla linea DMX (almeno ogni 300m se il cavo è di buona qualità) in modo che ripeta il segnale per i proiettori successivi.

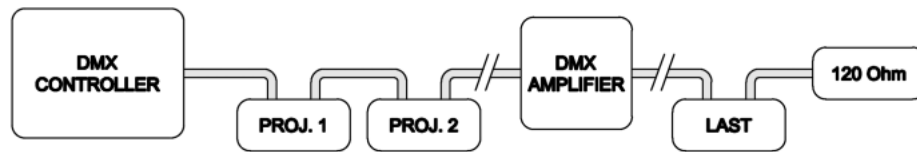

E' consigliabile terminare il circuito di segnale, all'interno dell'ultimo proiettore della catena o di ogni catena, con una resistenza (valore fra 82 e 120ohm) inserita fra il terminale positivo e negativo (+ e -).

#### DMX CONTROLLER OUT

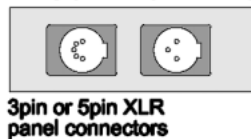

3pin or 5pin XLR panel connectors

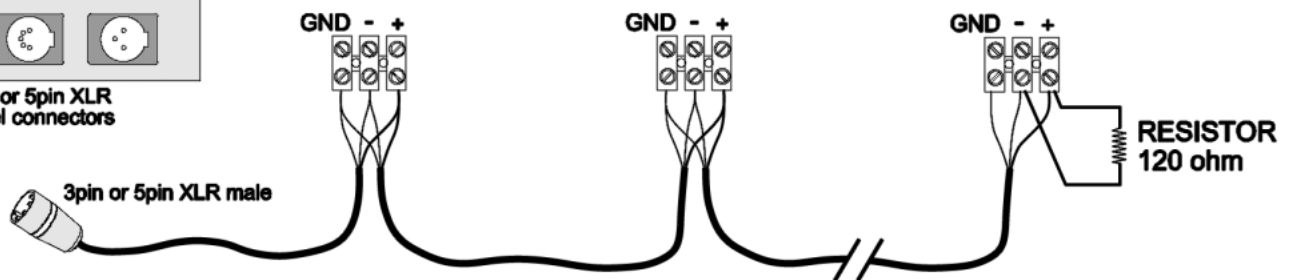

#### LAST PROJECTOR

La connessione al controller DMX va effettuata, nella maggior parte dei casi, tramite connettori XLR maschio a 3 o a 5 poli.

Sul PIN 1 del connettore XLR deve essere saldato lo schermo del cavo di segnale, sul PIN 2 deve essere saldato il negativo (per esempio, conduttore nero), sul PIN 3 deve essere saldato il positivo (per esempio, conduttore rosso o bianco).

Bisogna rispettare la colorazione e l'ordine di collegamento anche sui morsetti dei proiettori, con sequenza diversa i proiettori non rispondono al segnale DMX.

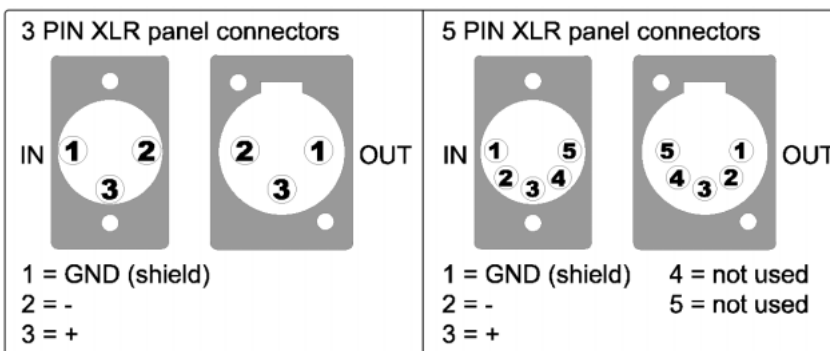

La connessione del segnale DMX all'interno del proiettore va eseguita collegando il segnale di entrata e il segnale di uscita direttamente nella morsettiera predisposta.

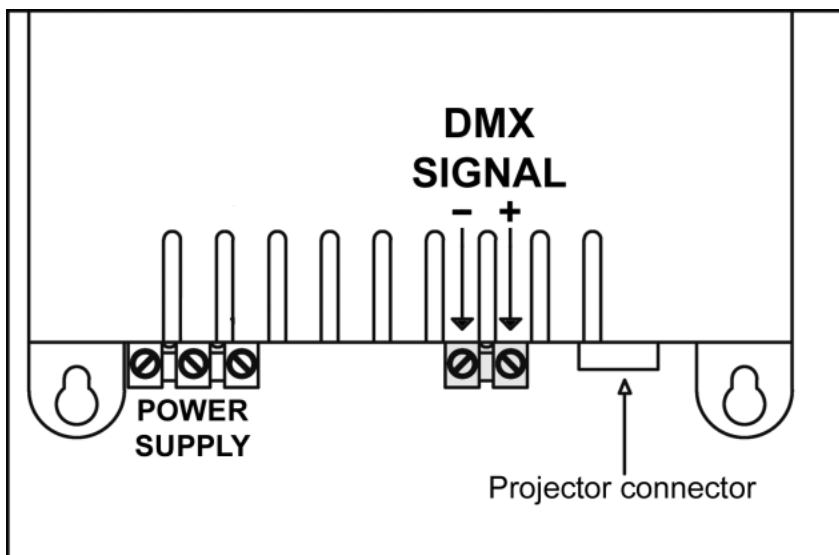

## Interfaccia utente

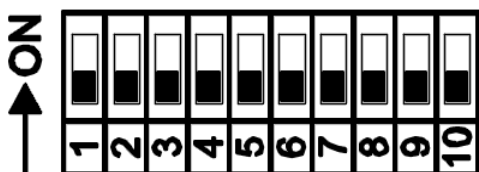

Per modificare l'indirizzo DMX e selezionare le configurazioni del proiettore, bisogna spostare su ON o OFF i micro interruttori (chiamati dip-switch) seguendo le tabelle e i disegni riportati nei vari capitoli.

## Specifiche DMX512

Il proiettore usa 8 canali DMX512 standard consecutivi a partire dall'indirizzo selezionato con i dip-switches

**Nel caso il proiettore non riceva segnale DMX tutti i led si accenderanno.**

CH.1 = VERDE	proporzionale da 0 a 100%
CH.2 = ROSSO	proporzionale da 0 a 100%
CH.3 = BLU	proporzionale da 0 a 100%
CH.4 = NON USATO	
CH.5 = NON USATO	
CH.6 = STROBO	dalla minima alla massima velocità
CH.7 = NON USATO	
CH.8 = NON USATO	

## Modalità di funzionamento

Il proiettore Slight Led può lavorare in **5 diverse modalità di funzionamento**, selezionabili tramite i dip-switches.

Non è possibile effettuare la modalità MASTER/SLAVE, un proiettore non può comandare altri proiettori.

### Modalità 1: Funzionamento con segnale DMX

Per comandare il proiettore con segnale DMX (da qualsiasi DMX controller) il **dip-switch 10** deve essere in posizione di **OFF**.

I proiettori eseguono i comandi che gli vengono forniti, tramite la linea DMX, da una centralina compatibile DMX512 oppure dalla centralina programmabile dedicata **Led Controller (AS147)** che permette di controllare fino a 6 gruppi indipendenti di proiettori.



E' necessario stabilire il primo canale di comando del proiettore, ovvero l'indirizzo DMX, in fabbrica viene impostato 1.

Ad ogni dip-switch è associato un valore numerico, la somma dei valori decimali stabilisce il primo canale DMX di comando.

DIP-SWITCH	Valore DECIMALE
Dip 1	DMX add. (1)
Dip 2	DMX add. (2)
Dip 3	DMX add. (4)
Dip 4	DMX add. (8)
Dip 5	DMX add. (16)
Dip 6	DMX add. (32)
Dip 7	DMX add. (64)
Dip 8	DMX add. (128)
Dip 9	DMX add. (256)
Dip 10	<b>OFF</b>

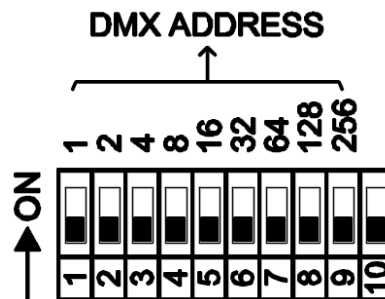

Per esempio: per impostare l'indirizzo DMX (DMX address) **39**, bisogna mettere su ON i dip-switches corrispondenti ai valori decimali 32, 4, 2 e 1 in quanto  $32+4+2+1=39$ .

**Proiettore con indirizzo DMX 1**

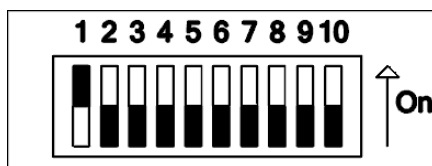

**Proiettore con indirizzo DMX 9**

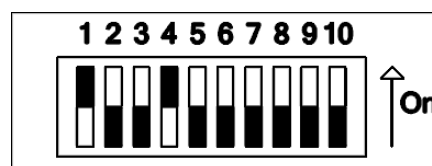

Alla fine del manuale (pag. 12) sono riportate le tabelle con le impostazioni dei dip-switches per ogni indirizzo DMX.

Esempio di collegamento di 11 Ceiling Led RGB su una linea DMX suddivisi in 4 gruppi indipendenti.

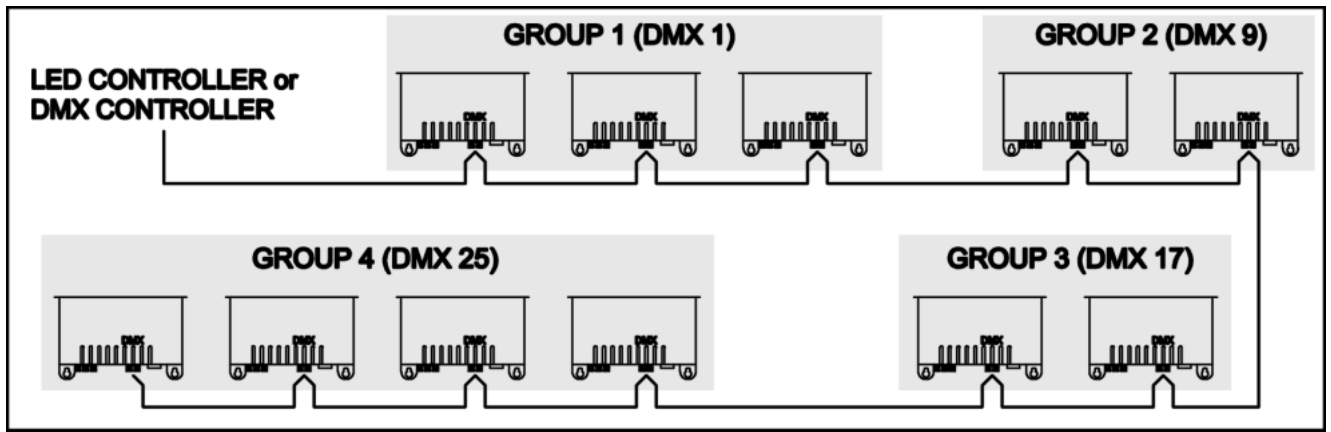

Led Controller (AS147) permette di controllare fino a 6 gruppi indipendenti di proiettori.

**Modalità 2: Funzionamento con controllo remoto a distanza**

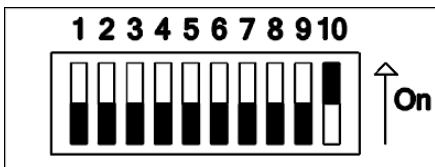

Il dip-switch 10 deve essere in posizione di ON.

Il proiettore esegue i comandi che gli vengono inviati da **Led Remote** ( telecomando - **AS148** ) che è OPZIONALE. Tramite il telecomando il proiettore può essere comandato anche a distanze di 10m (senza ostacoli ottici) e gli si può far eseguire una sequenza pre-programmata oppure essere comandato manualmente attraverso un controllo lineare dell'intensità del colore dei Led.

Per sincronizzare due o più proiettori, devono ricevere l'impulso del telecomando nello stesso momento.



**Modalità 3: Funzionamento fisso con tutti i led accesi**

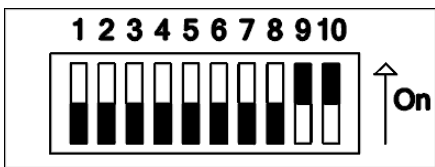

I dip-switches 9 e 10 devono essere in posizione di ON.

Il proiettore mantiene accesi fissi tutti i led alla massima potenza.

## Modalità 4: Funzionamento automatico con colore fisso

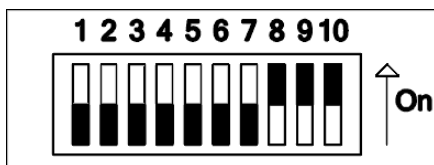

I dip-switches 8, 9, 10 devono essere in posizione di ON.

Il proiettore mantiene un colore fisso in base alla combinazione dei DIP dall' 1 al 5.

Tabella per la scelta del colore

Dip1	Dip2	Dip3	Dip4	Dip5	Rosso	Verde	Blu
off	off	off	off	off	0%	0%	0%
ON	off	off	off	off	25%	0%	0%
off	ON	off	off	off	50%	0%	0%
ON	ON	off	off	off	75%	0%	0%
off	off	ON	off	off	100%	0%	0%
ON	off	ON	off	off	0%	25%	0%
off	ON	ON	off	off	0%	50%	0%
ON	ON	ON	off	off	0%	75%	0%
off	off	off	ON	off	0%	100%	0%
ON	off	off	ON	off	0%	0%	25%
off	ON	off	ON	off	0%	0%	50%
ON	ON	off	ON	off	0%	0%	75%
off	off	ON	ON	off	0%	0%	100%
ON	off	ON	ON	off	25%	25%	0%
off	ON	ON	ON	off	50%	50%	0%
ON	ON	ON	ON	off	75%	75%	0%
off	off	off	off	ON	100%	100%	0%
ON	off	off	off	ON	25%	0%	25%
off	ON	off	off	ON	50%	0%	50%
ON	ON	off	off	ON	75%	0%	75%
off	off	ON	off	ON	100%	0%	100%
ON	off	ON	off	ON	0%	25%	25%
off	ON	ON	off	ON	0%	50%	50%
ON	ON	ON	off	ON	0%	75%	75%
off	off	off	ON	ON	0%	100%	100%
ON	off	off	ON	ON	25%	25%	25%
off	ON	off	ON	ON	50%	50%	50%
ON	ON	off	ON	ON	75%	75%	75%
off	off	ON	ON	ON	100%	100%	100%

## Modalità 5: Funzionamento automatico con gioco pre-programmato

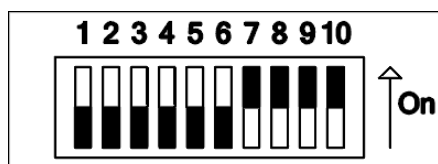

I dip-switches 7, 8, 9, 10 devono essere in posizione di ON.

Il proiettore esegue una sequenza preprogrammata e la ripete finché è alimentato.

# Tabelle indirizzi DMX

DMX	Dip1	Dip2	Dip3	Dip4	Dip5	Dip6	Dip7	Dip8	Dip9
	off	off	off	off	off	off	off	off	off
1	ON	off	off	off	off	off	off	off	off
2	off	ON	off	off	off	off	off	off	off
3	ON	ON	off	off	off	off	off	off	off
4	off	off	ON	off	off	off	off	off	off
5	ON	off	ON	off	off	off	off	off	off
6	off	ON	ON	off	off	off	off	off	off
7	ON	ON	ON	off	off	off	off	off	off
8	off	off	off	ON	off	off	off	off	off
9	ON	off	off	ON	off	off	off	off	off
10	off	ON	off	ON	off	off	off	off	off
11	ON	ON	off	ON	off	off	off	off	off
12	off	off	ON	ON	off	off	off	off	off
13	ON	off	ON	ON	off	off	off	off	off
14	off	ON	ON	ON	off	off	off	off	off
15	ON	ON	ON	ON	off	off	off	off	off
16	off	off	off	off	ON	off	off	off	off
17	ON	off	off	off	ON	off	off	off	off
18	off	ON	off	off	ON	off	off	off	off
19	ON	ON	off	off	ON	off	off	off	off
20	off	off	ON	off	ON	off	off	off	off
21	ON	off	ON	off	ON	off	off	off	off
22	off	ON	ON	off	ON	off	off	off	off
23	ON	ON	ON	off	ON	off	off	off	off
24	off	off	off	ON	ON	off	off	off	off
25	ON	off	off	ON	ON	off	off	off	off
26	off	ON	off	ON	ON	off	off	off	off
27	ON	ON	off	ON	ON	off	off	off	off
28	off	off	ON	ON	ON	off	off	off	off
29	ON	off	ON	ON	ON	off	off	off	off
30	off	ON	ON	ON	ON	off	off	off	off
31	ON	ON	ON	ON	ON	off	off	off	off
32	off	off	off	off	off	ON	off	off	off
33	ON	off	off	off	off	ON	off	off	off
34	off	ON	off	off	off	ON	off	off	off
35	ON	ON	off	off	off	ON	off	off	off
36	off	off	ON	off	off	ON	off	off	off
37	ON	off	ON	off	off	ON	off	off	off
38	off	ON	ON	off	off	ON	off	off	off
39	ON	ON	ON	off	off	ON	off	off	off
40	off	off	off	ON	off	ON	off	off	off
41	ON	off	off	ON	off	ON	off	off	off
42	off	ON	off	ON	off	ON	off	off	off
43	ON	ON	off	ON	off	ON	off	off	off
44	off	off	ON	ON	off	ON	off	off	off
45	ON	off	ON	ON	off	ON	off	off	off
46	off	ON	ON	ON	off	ON	off	off	off
47	ON	ON	ON	ON	off	ON	off	off	off
48	off	off	off	off	ON	ON	off	off	off
49	ON	off	off	off	ON	ON	off	off	off
50	off	ON	off	off	ON	ON	off	off	off
51	ON	ON	off	off	ON	ON	off	off	off
52	off	off	ON	off	ON	ON	off	off	off
53	ON	off	ON	off	ON	ON	off	off	off
54	off	ON	ON	off	ON	ON	off	off	off
55	ON	ON	ON	off	ON	ON	off	off	off
56	off	off	off	ON	ON	ON	off	off	off
57	ON	off	off	ON	ON	ON	off	off	off
58	off	ON	off	ON	ON	ON	off	off	off
59	ON	ON	off	ON	ON	ON	off	off	off
60	off	off	ON	ON	ON	ON	off	off	off
61	ON	off	ON	ON	ON	ON	off	off	off
62	off	ON	ON	ON	ON	ON	off	off	off
63	ON	ON	ON	ON	ON	ON	off	off	off

DMX	Dip1	Dip2	Dip3	Dip4	Dip5	Dip6	Dip7	Dip8	Dip9
64	off	off	off	off	off	off	ON	off	off
65	ON	off	off	off	off	off	ON	off	off
66	off	ON	off	off	off	off	ON	off	off
67	ON	ON	off	off	off	off	ON	off	off
68	off	off	ON	off	off	off	ON	off	off
69	ON	off	ON	off	off	off	ON	off	off
70	off	ON	ON	off	off	off	ON	off	off
71	ON	ON	ON	off	off	off	ON	off	off
72	off	off	off	ON	off	off	ON	off	off
73	ON	off	off	ON	off	off	ON	off	off
74	off	ON	off	ON	off	off	ON	off	off
75	ON	ON	off	ON	off	off	ON	off	off
76	off	off	ON	ON	off	off	ON	off	off
77	ON	off	ON	ON	off	off	ON	off	off
78	off	ON	ON	ON	off	off	ON	off	off
79	ON	ON	ON	ON	off	off	ON	off	off
80	off	off	off	off	ON	off	ON	off	off
81	ON	off	off	off	ON	off	ON	off	off
82	off	ON	off	off	ON	off	ON	off	off
83	ON	ON	off	off	ON	off	ON	off	off
84	off	off	ON	off	ON	off	ON	off	off
85	ON	off	ON	off	ON	off	ON	off	off
86	off	ON	ON	off	ON	off	ON	off	off
87	ON	ON	ON	off	ON	off	ON	off	off
88	off	off	off	ON	ON	off	ON	off	off
89	ON	off	off	ON	ON	off	ON	off	off
90	off	ON	off	ON	ON	off	ON	off	off
91	ON	ON	off	ON	ON	off	ON	off	off
92	off	off	ON	ON	ON	off	ON	off	off
93	ON	off	ON	ON	ON	off	ON	off	off
94	off	ON	ON	ON	ON	off	ON	off	off
95	ON	ON	ON	ON	ON	off	ON	off	off
96	off	off	off	off	off	ON	ON	off	off
97	ON	off	off	off	off	ON	ON	off	off
98	off	ON	off	off	off	ON	ON	off	off
99	ON	ON	off	off	off	ON	ON	off	off
100	off	off	ON	off	off	ON	ON	off	off
101	ON	off	ON	off	off	ON	ON	off	off
102	off	ON	ON	off	off	ON	ON	off	off
103	ON	ON	ON	off	off	ON	ON	off	off
104	off	off	off	ON	off	ON	ON	off	off
105	ON	off	off	ON	off	ON	ON	off	off
106	off	ON	off	ON	off	ON	ON	off	off
107	ON	ON	off	ON	off	ON	ON	off	off
108	off	off	ON	ON	off	ON	ON	off	off
109	ON	off	ON	ON	off	ON	ON	off	off
110	off	ON	ON	ON	off	ON	ON	off	off
111	ON	ON	ON	ON	off	ON	ON	off	off
112	off	off	off	off	ON	ON	ON	off	off
113	ON	off	off	off	ON	ON	ON	off	off
114	off	ON	off	off	ON	ON	ON	off	off
115	ON	ON	off	off	ON	ON	ON	off	off
116	off	off	ON	off	ON	ON	ON	off	off
117	ON	off	ON	off	ON	ON	ON	off	off
118	off	ON	ON	off	ON	ON	ON	off	off
119	ON	ON	ON	off	ON	ON	ON	off	off
120	off	off	off	ON	ON	ON	ON	off	off
121	ON	off	off	ON	ON	ON	ON	off	off
122	off	ON	off	ON	ON	ON	ON	off	off
123	ON	ON	off	ON	ON	ON	ON	off	off
124	off	off	ON	ON	ON	ON	ON	off	off
125	ON	off	ON	ON	ON	ON	ON	off	off
126	off	ON	ON	ON	ON	ON	ON	off	off
127	ON	ON	ON	ON	ON	ON	ON	off	off



DMX	Dip1	Dip2	Dip3	Dip4	Dip5	Dip6	Dip7	Dip8	Dip9
128	off	off	off	off	off	off	off	ON	off
129	ON	off	off	off	off	off	off	ON	off
130	off	ON	off	off	off	off	off	ON	off
131	ON	ON	off	off	off	off	off	ON	off
132	off	off	ON	off	off	off	off	ON	off
133	ON	off	ON	off	off	off	off	ON	off
134	off	ON	ON	off	off	off	off	ON	off
135	ON	ON	ON	off	off	off	off	ON	off
136	off	off	off	ON	off	off	off	ON	off
137	ON	off	off	ON	off	off	off	ON	off
138	off	ON	off	ON	off	off	off	ON	off
139	ON	ON	off	ON	off	off	off	ON	off
140	off	off	ON	ON	off	off	off	ON	off
141	ON	off	ON	ON	off	off	off	ON	off
142	off	ON	ON	ON	off	off	off	ON	off
143	ON	ON	ON	ON	off	off	off	ON	off
144	off	off	off	off	ON	off	off	ON	off
145	ON	off	off	off	ON	off	off	ON	off
146	off	ON	off	off	ON	off	off	ON	off
147	ON	ON	off	off	ON	off	off	ON	off
148	off	off	ON	off	ON	off	off	ON	off
149	ON	off	ON	off	ON	off	off	ON	off
150	off	ON	ON	off	ON	off	off	ON	off
151	ON	ON	ON	off	ON	off	off	ON	off
152	off	off	off	ON	ON	off	off	ON	off
153	ON	off	off	ON	ON	off	off	ON	off
154	off	ON	off	ON	ON	off	off	ON	off
155	ON	ON	off	ON	ON	off	off	ON	off
156	off	off	ON	ON	ON	off	off	ON	off
157	ON	off	ON	ON	ON	off	off	ON	off
158	off	ON	ON	ON	ON	off	off	ON	off
159	ON	ON	ON	ON	ON	off	off	ON	off
160	off	off	off	off	off	ON	off	ON	off
161	ON	off	off	off	off	ON	off	ON	off
162	off	ON	off	off	off	ON	off	ON	off
163	ON	ON	off	off	off	ON	off	ON	off
164	off	off	ON	off	off	ON	off	ON	off
165	ON	off	ON	off	off	ON	off	ON	off
166	off	ON	ON	off	off	ON	off	ON	off
167	ON	ON	ON	off	off	ON	off	ON	off
168	off	off	off	ON	off	ON	off	ON	off
169	ON	off	off	ON	off	ON	off	ON	off
170	off	ON	off	ON	off	ON	off	ON	off
171	ON	ON	off	ON	off	ON	off	ON	off
172	off	off	ON	ON	off	ON	off	ON	off
173	ON	off	ON	ON	off	ON	off	ON	off
174	off	ON	ON	ON	off	ON	off	ON	off
175	ON	ON	ON	ON	off	ON	off	ON	off
176	off	off	off	off	ON	ON	off	ON	off
177	ON	off	off	off	ON	ON	off	ON	off
178	off	ON	off	off	ON	ON	off	ON	off
179	ON	ON	off	off	ON	ON	off	ON	off
180	off	off	ON	off	ON	ON	off	ON	off
181	ON	off	ON	off	ON	ON	off	ON	off
182	off	ON	ON	off	ON	ON	off	ON	off
183	ON	ON	ON	off	ON	ON	off	ON	off
184	off	off	off	ON	ON	ON	off	ON	off
185	ON	off	off	ON	ON	ON	off	ON	off
186	off	ON	off	ON	ON	ON	off	ON	off
187	ON	ON	off	ON	ON	ON	off	ON	off
188	off	off	ON	ON	ON	ON	off	ON	off
189	ON	off	ON	ON	ON	ON	off	ON	off
190	off	ON	ON	ON	ON	ON	off	ON	off
191	ON	ON	ON	ON	ON	ON	off	ON	off

DMX	Dip1	Dip2	Dip3	Dip4	Dip5	Dip6	Dip7	Dip8	Dip9
192	off	off	off	off	off	off	ON	ON	off
193	ON	off	off	off	off	off	ON	ON	off
194	off	ON	off	off	off	off	ON	ON	off
195	ON	ON	off	off	off	off	ON	ON	off
196	off	off	ON	off	off	off	ON	ON	off
197	ON	off	ON	off	off	off	ON	ON	off
198	off	ON	ON	off	off	off	ON	ON	off
199	ON	ON	ON	off	off	off	ON	ON	off
200	off	off	off	ON	off	off	ON	ON	off
201	ON	off	off	ON	off	off	ON	ON	off
202	off	ON	off	ON	off	off	ON	ON	off
203	ON	ON	off	ON	off	off	ON	ON	off
204	off	off	ON	ON	off	off	ON	ON	off
205	ON	off	ON	ON	off	off	ON	ON	off
206	off	ON	ON	ON	off	off	ON	ON	off
207	ON	ON	ON	ON	off	off	ON	ON	off
208	off	off	off	off	ON	off	ON	ON	off
209	ON	off	off	off	ON	off	ON	ON	off
210	off	ON	off	off	ON	off	ON	ON	off
211	ON	ON	off	off	ON	off	ON	ON	off
212	off	off	ON	off	ON	off	ON	ON	off
213	ON	off	ON	off	ON	off	ON	ON	off
214	off	ON	ON	off	ON	off	ON	ON	off
215	ON	ON	ON	off	ON	off	ON	ON	off
216	off	off	off	ON	ON	off	ON	ON	off
217	ON	off	off	ON	ON	off	ON	ON	off
218	off	ON	off	ON	ON	off	ON	ON	off
219	ON	ON	off	ON	ON	off	ON	ON	off
220	off	off	ON	ON	ON	off	ON	ON	off
221	ON	off	ON	ON	ON	off	ON	ON	off
222	off	ON	ON	ON	ON	off	ON	ON	off
223	ON	ON	ON	ON	ON	off	ON	ON	off
224	off	off	off	off	off	ON	ON	ON	off
225	ON	off	off	off	off	ON	ON	ON	off
226	off	ON	off	off	off	ON	ON	ON	off
227	ON	ON	off	off	off	ON	ON	ON	off
228	off	off	ON	off	off	ON	ON	ON	off
229	ON	off	ON	off	off	ON	ON	ON	off
230	off	ON	ON	off	off	ON	ON	ON	off
231	ON	ON	ON	off	off	ON	ON	ON	off
232	off	off	off	ON	off	ON	ON	ON	off
233	ON	off	off	ON	off	ON	ON	ON	off
234	off	ON	off	ON	off	ON	ON	ON	off
235	ON	ON	off	ON	off	ON	ON	ON	off
236	off	off	ON	ON	off	ON	ON	ON	off
237	ON	off	ON	ON	off	ON	ON	ON	off
238	off	ON	ON	ON	off	ON	ON	ON	off
239	ON	ON	ON	ON	off	ON	ON	ON	off
240	off	off	off	off	ON	ON	ON	ON	off
241	ON	off	off	off	ON	ON	ON	ON	off
242	off	ON	off	off	ON	ON	ON	ON	off
243	ON	ON	off	off	ON	ON	ON	ON	off
244	off	off	ON	off	ON	ON	ON	ON	off
245	ON	off	ON	off	ON	ON	ON	ON	off
246	off	ON	ON	off	ON	ON	ON	ON	off
247	ON	ON	ON	off	ON	ON	ON	ON	off
248	off	off	off	ON	ON	ON	ON	ON	off
249	ON	off	off	ON	ON	ON	ON	ON	off
250	off	ON	off	ON	ON	ON	ON	ON	off
251	ON	ON	off	ON	ON	ON	ON	ON	off
252	off	off	ON	ON	ON	ON	ON	ON	off
253	ON	off	ON	ON	ON	ON	ON	ON	off
254	off	ON	ON	ON	ON	ON	ON	ON	off
255	ON	ON	ON	ON	ON	ON	ON	ON	off



DMX	Dip1	Dip2	Dip3	Dip4	Dip5	Dip6	Dip7	Dip8	Dip9
256	off	off	off	off	off	off	off	off	ON
257	ON	off	off	off	off	off	off	off	ON
258	off	ON	off	off	off	off	off	off	ON
259	ON	ON	off	off	off	off	off	off	ON
260	off	off	ON	off	off	off	off	off	ON
261	ON	off	ON	off	off	off	off	off	ON
262	off	ON	ON	off	off	off	off	off	ON
263	ON	ON	ON	off	off	off	off	off	ON
264	off	off	off	ON	off	off	off	off	ON
265	ON	off	off	ON	off	off	off	off	ON
266	off	ON	off	ON	off	off	off	off	ON
267	ON	ON	off	ON	off	off	off	off	ON
268	off	off	ON	ON	off	off	off	off	ON
269	ON	off	ON	ON	off	off	off	off	ON
270	off	ON	ON	ON	off	off	off	off	ON
271	ON	ON	ON	ON	off	off	off	off	ON
272	off	off	off	off	ON	off	off	off	ON
273	ON	off	off	off	ON	off	off	off	ON
274	off	ON	off	off	ON	off	off	off	ON
275	ON	ON	off	off	ON	off	off	off	ON
276	off	off	ON	off	ON	off	off	off	ON
277	ON	off	ON	off	ON	off	off	off	ON
278	off	ON	ON	off	ON	off	off	off	ON
279	ON	ON	ON	off	ON	off	off	off	ON
280	off	off	off	ON	ON	off	off	off	ON
281	ON	off	off	ON	ON	off	off	off	ON
282	off	ON	off	ON	ON	off	off	off	ON
283	ON	ON	off	ON	ON	off	off	off	ON
284	off	off	ON	ON	ON	off	off	off	ON
285	ON	off	ON	ON	ON	off	off	off	ON
286	off	ON	ON	ON	ON	off	off	off	ON
287	ON	ON	ON	ON	ON	off	off	off	ON
288	off	off	off	off	off	ON	off	off	ON
289	ON	off	off	off	off	ON	off	off	ON
290	off	ON	off	off	off	ON	off	off	ON
291	ON	ON	off	off	off	ON	off	off	ON
292	off	off	ON	off	off	ON	off	off	ON
293	ON	off	ON	off	off	ON	off	off	ON
294	off	ON	ON	off	off	ON	off	off	ON
295	ON	ON	ON	off	off	ON	off	off	ON
296	off	off	off	ON	off	ON	off	off	ON
297	ON	off	off	ON	off	ON	off	off	ON
298	off	ON	off	ON	off	ON	off	off	ON
299	ON	ON	off	ON	off	ON	off	off	ON
300	off	off	ON	ON	off	ON	off	off	ON
301	ON	off	ON	ON	off	ON	off	off	ON
302	off	ON	ON	ON	off	ON	off	off	ON
303	ON	ON	ON	ON	off	ON	off	off	ON
304	off	off	off	off	ON	ON	off	off	ON
305	ON	off	off	off	ON	ON	off	off	ON
306	off	ON	off	off	ON	ON	off	off	ON
307	ON	ON	off	off	ON	ON	off	off	ON
308	off	off	ON	off	ON	ON	off	off	ON
309	ON	off	ON	off	ON	ON	off	off	ON
310	off	ON	ON	off	ON	ON	off	off	ON
311	ON	ON	ON	off	ON	ON	off	off	ON
312	off	off	off	ON	ON	ON	off	off	ON
313	ON	off	off	ON	ON	ON	off	off	ON
314	off	ON	off	ON	ON	ON	off	off	ON
315	ON	ON	off	ON	ON	ON	off	off	ON
316	off	off	ON	ON	ON	ON	off	off	ON
317	ON	off	ON	ON	ON	ON	off	off	ON
318	off	ON	ON	ON	ON	ON	off	off	ON
319	ON	ON	ON	ON	ON	ON	off	off	ON

DMX	Dip1	Dip2	Dip3	Dip4	Dip5	Dip6	Dip7	Dip8	Dip9
320	off	off	off	off	off	off	ON	off	ON
321	ON	off	off	off	off	off	ON	off	ON
322	off	ON	off	off	off	off	ON	off	ON
323	ON	ON	off	off	off	off	ON	off	ON
324	off	off	ON	off	off	off	ON	off	ON
325	ON	off	ON	off	off	off	ON	off	ON
326	off	ON	ON	off	off	off	ON	off	ON
327	ON	ON	ON	off	off	off	ON	off	ON
328	off	off	off	ON	off	off	ON	off	ON
329	ON	off	off	ON	off	off	ON	off	ON
330	off	ON	off	ON	off	off	ON	off	ON
331	ON	ON	off	ON	off	off	ON	off	ON
332	off	off	ON	ON	off	off	ON	off	ON
333	ON	off	ON	ON	off	off	ON	off	ON
334	off	ON	ON	ON	off	off	ON	off	ON
335	ON	ON	ON	ON	off	off	ON	off	ON
336	off	off	off	off	ON	off	ON	off	ON
337	ON	off	off	off	ON	off	ON	off	ON
338	off	ON	off	off	ON	off	ON	off	ON
339	ON	ON	off	off	ON	off	ON	off	ON
340	off	off	ON	off	ON	off	ON	off	ON
341	ON	off	ON	off	ON	off	ON	off	ON
342	off	ON	ON	off	ON	off	ON	off	ON
343	ON	ON	ON	off	ON	off	ON	off	ON
344	off	off	off	ON	ON	off	ON	off	ON
345	ON	off	off	ON	ON	off	ON	off	ON
346	off	ON	off	ON	ON	off	ON	off	ON
347	ON	ON	off	ON	ON	off	ON	off	ON
348	off	off	ON	ON	ON	off	ON	off	ON
349	ON	off	ON	ON	ON	off	ON	off	ON
350	off	ON	ON	ON	ON	off	ON	off	ON
351	ON	ON	ON	ON	ON	off	ON	off	ON
352	off	off	off	off	off	ON	ON	off	ON
353	ON	off	off	off	off	ON	ON	off	ON
354	off	ON	off	off	off	ON	ON	off	ON
355	ON	ON	off	off	off	ON	ON	off	ON
356	off	off	ON	off	off	ON	ON	off	ON
357	ON	off	ON	off	off	ON	ON	off	ON
358	off	ON	ON	off	off	ON	ON	off	ON
359	ON	ON	ON	off	off	ON	ON	off	ON
360	off	off	off	ON	off	ON	ON	off	ON
361	ON	off	off	ON	off	ON	ON	off	ON
362	off	ON	off	ON	off	ON	ON	off	ON
363	ON	ON	off	ON	off	ON	ON	off	ON
364	off	off	ON	ON	off	ON	ON	off	ON
365	ON	off	ON	ON	off	ON	ON	off	ON
366	off	ON	ON	ON	off	ON	ON	off	ON
367	ON	ON	ON	ON	off	ON	ON	off	ON
368	off	off	off	off	ON	ON	ON	off	ON
369	ON	off	off	off	ON	ON	ON	off	ON
370	off	ON	off	off	ON	ON	ON	off	ON
371	ON	ON	off	off	ON	ON	ON	off	ON
372	off	off	ON	off	ON	ON	ON	off	ON
373	ON	off	ON	off	ON	ON	ON	off	ON
374	off	ON	ON	off	ON	ON	ON	off	ON
375	ON	ON	ON	off	ON	ON	ON	off	ON
376	off	off	off	ON	ON	ON	ON	off	ON
377	ON	off	off	ON	ON	ON	ON	off	ON
378	off	ON	off	ON	ON	ON	ON	off	ON
379	ON	ON	off	ON	ON	ON	ON	off	ON
380	off	off	ON	ON	ON	ON	ON	off	ON
381	ON	off	ON	ON	ON	ON	ON	off	ON
382	off	ON	ON	ON	ON	ON	ON	off	ON
383	ON	ON	ON	ON	ON	ON	ON	off	ON

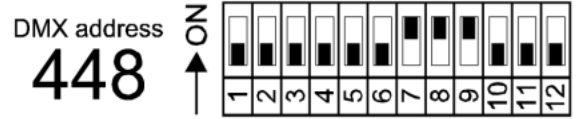
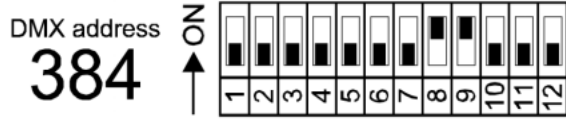

DMX	Dip1	Dip2	Dip3	Dip4	Dip5	Dip6	Dip7	Dip8	Dip9
384	off	off	off	off	off	off	off	ON	ON
385	ON	off	off	off	off	off	off	ON	ON
386	off	ON	off	off	off	off	off	ON	ON
387	ON	ON	off	off	off	off	off	ON	ON
388	off	off	ON	off	off	off	off	ON	ON
389	ON	off	ON	off	off	off	off	ON	ON
390	off	ON	ON	off	off	off	off	ON	ON
391	ON	ON	ON	off	off	off	off	ON	ON
392	off	off	off	ON	off	off	off	ON	ON
393	ON	off	off	ON	off	off	off	ON	ON
394	off	ON	off	ON	off	off	off	ON	ON
395	ON	ON	off	ON	off	off	off	ON	ON
396	off	off	ON	ON	off	off	off	ON	ON
397	ON	off	ON	ON	off	off	off	ON	ON
398	off	ON	ON	ON	off	off	off	ON	ON
399	ON	ON	ON	ON	off	off	off	ON	ON
400	off	off	off	off	ON	off	off	ON	ON
401	ON	off	off	off	ON	off	off	ON	ON
402	off	ON	off	off	ON	off	off	ON	ON
403	ON	ON	off	off	ON	off	off	ON	ON
404	off	off	ON	off	ON	off	off	ON	ON
405	ON	off	ON	off	ON	off	off	ON	ON
406	off	ON	ON	off	ON	off	off	ON	ON
407	ON	ON	ON	off	ON	off	off	ON	ON
408	off	off	off	ON	ON	off	off	ON	ON
409	ON	off	off	ON	ON	off	off	ON	ON
410	off	ON	off	ON	ON	off	off	ON	ON
411	ON	ON	off	ON	ON	off	off	ON	ON
412	off	off	ON	ON	ON	off	off	ON	ON
413	ON	off	ON	ON	ON	off	off	ON	ON
414	off	ON	ON	ON	ON	off	off	ON	ON
415	ON	ON	ON	ON	ON	off	off	ON	ON
416	off	off	off	off	off	ON	off	ON	ON
417	ON	off	off	off	off	ON	off	ON	ON
418	off	ON	off	off	off	ON	off	ON	ON
419	ON	ON	off	off	off	ON	off	ON	ON
420	off	off	ON	off	off	ON	off	ON	ON
421	ON	off	ON	off	off	ON	off	ON	ON
422	off	ON	ON	off	off	ON	off	ON	ON
423	ON	ON	ON	off	off	ON	off	ON	ON
424	off	off	off	ON	off	ON	off	ON	ON
425	ON	off	off	ON	off	ON	off	ON	ON
426	off	ON	off	ON	off	ON	off	ON	ON
427	ON	ON	off	ON	off	ON	off	ON	ON
428	off	off	ON	ON	off	ON	off	ON	ON
429	ON	off	ON	ON	off	ON	off	ON	ON
430	off	ON	ON	ON	off	ON	off	ON	ON
431	ON	ON	ON	ON	off	ON	off	ON	ON
432	off	off	off	off	ON	ON	off	ON	ON
433	ON	off	off	off	ON	ON	off	ON	ON
434	off	ON	off	off	ON	ON	off	ON	ON
435	ON	ON	off	off	ON	ON	off	ON	ON
436	off	off	ON	off	ON	ON	off	ON	ON
437	ON	off	ON	off	ON	ON	off	ON	ON
438	off	ON	ON	off	ON	ON	off	ON	ON
439	ON	ON	ON	off	ON	ON	off	ON	ON
440	off	off	off	ON	ON	ON	off	ON	ON
441	ON	off	off	ON	ON	ON	off	ON	ON
442	off	ON	off	ON	ON	ON	off	ON	ON
443	ON	ON	off	ON	ON	ON	off	ON	ON
444	off	off	ON	ON	ON	ON	off	ON	ON
445	ON	off	ON	ON	ON	ON	off	ON	ON
446	off	ON	ON	ON	ON	ON	off	ON	ON
447	ON	ON	ON	ON	ON	ON	off	ON	ON

DMX	Dip1	Dip2	Dip3	Dip4	Dip5	Dip6	Dip7	Dip8	Dip9
448	off	off	off	off	off	off	ON	ON	ON
449	ON	off	off	off	off	off	ON	ON	ON
450	off	ON	off	off	off	off	ON	ON	ON
451	ON	ON	off	off	off	off	ON	ON	ON
452	off	off	ON	off	off	off	ON	ON	ON
453	ON	off	ON	off	off	off	ON	ON	ON
454	off	ON	ON	off	off	off	ON	ON	ON
455	ON	ON	ON	off	off	off	ON	ON	ON
456	off	off	off	ON	off	off	ON	ON	ON
457	ON	off	off	ON	off	off	ON	ON	ON
458	off	ON	off	ON	off	off	ON	ON	ON
459	ON	ON	off	ON	off	off	ON	ON	ON
460	off	off	ON	ON	off	off	ON	ON	ON
461	ON	off	ON	ON	off	off	ON	ON	ON
462	off	ON	ON	ON	off	off	ON	ON	ON
463	ON	ON	ON	ON	off	off	ON	ON	ON
464	off	off	off	off	ON	off	ON	ON	ON
465	ON	off	off	off	ON	off	ON	ON	ON
466	off	ON	off	off	ON	off	ON	ON	ON
467	ON	ON	off	off	ON	off	ON	ON	ON
468	off	off	ON	off	ON	off	ON	ON	ON
469	ON	off	ON	off	ON	off	ON	ON	ON
470	off	ON	ON	off	ON	off	ON	ON	ON
471	ON	ON	ON	off	ON	off	ON	ON	ON
472	off	off	off	ON	ON	off	ON	ON	ON
473	ON	off	off	ON	ON	off	ON	ON	ON
474	off	ON	off	ON	ON	off	ON	ON	ON
475	ON	ON	off	ON	ON	off	ON	ON	ON
476	off	off	ON	ON	ON	off	ON	ON	ON
477	ON	off	ON	ON	ON	off	ON	ON	ON
478	off	ON	ON	ON	ON	off	ON	ON	ON
479	ON	ON	ON	ON	ON	off	ON	ON	ON
480	off	off	off	off	off	ON	ON	ON	ON
481	ON	off	off	off	off	ON	ON	ON	ON
482	off	ON	off	off	off	ON	ON	ON	ON
483	ON	ON	off	off	off	ON	ON	ON	ON
484	off	off	ON	off	off	ON	ON	ON	ON
485	ON	off	ON	off	off	ON	ON	ON	ON
486	off	ON	ON	off	off	ON	ON	ON	ON
487	ON	ON	ON	off	off	ON	ON	ON	ON
488	off	off	off	ON	off	ON	ON	ON	ON
489	ON	off	off	ON	off	ON	ON	ON	ON
490	off	ON	off	ON	off	ON	ON	ON	ON
491	ON	ON	off	ON	off	ON	ON	ON	ON
492	off	off	ON	ON	off	ON	ON	ON	ON
493	ON	off	ON	ON	off	ON	ON	ON	ON
494	off	ON	ON	ON	off	ON	ON	ON	ON
495	ON	ON	ON	ON	off	ON	ON	ON	ON
496	off	off	off	off	ON	ON	ON	ON	ON
497	ON	off	off	off	ON	ON	ON	ON	ON
498	off	ON	off	off	ON	ON	ON	ON	ON
499	ON	ON	off	off	ON	ON	ON	ON	ON
500	off	off	ON	off	ON	ON	ON	ON	ON
501	ON	off	ON	off	ON	ON	ON	ON	ON
502	off	ON	ON	off	ON	ON	ON	ON	ON
503	ON	ON	ON	off	ON	ON	ON	ON	ON
504	off	off	off	ON	ON	ON	ON	ON	ON
505	ON	off	off	ON	ON	ON	ON	ON	ON
506	off	ON	off	ON	ON	ON	ON	ON	ON
507	ON	ON	off	ON	ON	ON	ON	ON	ON
508	off	off	ON	ON	ON	ON	ON	ON	ON
509	ON	off	ON	ON	ON	ON	ON	ON	ON
510	off	ON	ON	ON	ON	ON	ON	ON	ON
511	ON	ON	ON	ON	ON	ON	ON	ON	ON

## **Parti di ricambio**

Quando vengono ordinati pezzi di ricambio, è necessario menzionare il modello e il numero di serie del proiettore.

Chiamate il vostro rivenditore di zona per avere qualsiasi assistenza o direttamente il costruttore.

### **LISTA PEZZI DI RICAMBIO**

<b>CODICE</b>	<b>DESCRIZIONE</b>
SCH99/012	Scheda elettronica 243 Vetro sabbato, diametro 118mm Vetro trasparente, diametro 118mm

L'uso improprio di questo proiettore inficia la garanzia e la nostra responsabilità. Tutti i dati sono stati redatti e controllati con la massima cura; non ci assumiamo in ogni caso alcuna responsabilità per eventuali errori od omissioni. Ci riserviamo il diritto di apporre modifiche e/o migliorie che ritenessimo necessarie, senza ulteriore preavviso. È vietata qualunque riproduzione di questo manuale, anche parziale, se non espressamente autorizzata.