



## **LAMPO lighting designers**

46042 Castel Goffredo - Mantova - Italy

Via Portogallo, 4

tel +39 0376 770869 fax +39 0376 780947

www.lamposrl.it

e-mail info@lamposrl sales@lamposrl

tech@lamposrl exp@lamposrl

**ENGLISH**

# **DECORATOR 250W RGB**



## **IP66 colour changer**

**USER' S MANUAL release 1.0**

*This manual must be considered an integral part of the projector*

**BEFORE CONNECTING AND USING THE PROJECTOR, IT IS IMPORTANT TO READ CAREFULLY ALL THE INSTRUCTIONS IN THIS MANUAL.**

**QUALIFIED PERSONNEL ONLY, IN COMPLIANCE WITH ALL THE SECURITY LAWS, CAN DO THE INSTALLATION, THE MAINTENANCE AND THE UTILISATION OF THIS PROJECTOR.**

**BEFORE CONNECTING THE PROJECTOR, MAKE SURE THAT THE FREQUENCY AND THE VOLTAGE VALUES ARE SUITABLE AS SPECIFIED ON THE PROJECTOR.**

**FOR ANY DOUBT, CONTACT YOUR SUPPLIER OR SEND AN E-MAIL TO:**

**tech@lamposrl.it**

**IP66** SOLID: Dust-tight  
WATER: Protected against heavy seas



Suitable for direct mounting on normally flammable surfaces



Minimum distance from lighted objects (meters)

**ta 30 °C** Rated maximum ambient temperature (indoor with ventilation)



Connection must be made to a power supply system fitted with efficient earthing (EN60598-1 – Class I fixture)

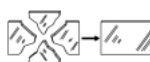

Replace any cracked protective shield, dichroic filter or lens



Ignitor circuit lamp have very high voltage

## **Index**

<b>Dimensions and weight</b>	<b>-----</b>	<b>page 2</b>
<b>Technical data</b>	<b>-----</b>	<b>page 2</b>
<b>Storage</b>	<b>-----</b>	<b>page 2</b>
<b>Admissible environmental conditions</b>	<b>-----</b>	<b>page 2</b>
<b>Power supply</b>	<b>-----</b>	<b>page 3</b>
<b>Example of connection</b>	<b>-----</b>	<b>page 4</b>
<b>DMX signal cable</b>	<b>-----</b>	<b>page 4</b>
<b>User's interface</b>	<b>-----</b>	<b>page 6</b>
<b>DMX512 specifications</b>	<b>-----</b>	<b>page 6</b>
<b>DMX starting address</b>	<b>-----</b>	<b>page 6</b>
<b>Stand alone mode (colour sequence)</b>	<b>-----</b>	<b>page 11</b>
<b>Stand alone mode (one fixed colour)</b>	<b>-----</b>	<b>page 12</b>
<b>Lamp replacement</b>	<b>-----</b>	<b>page 14</b>
<b>Spare parts</b>	<b>-----</b>	<b>page 15</b>

## Dimensions & weight

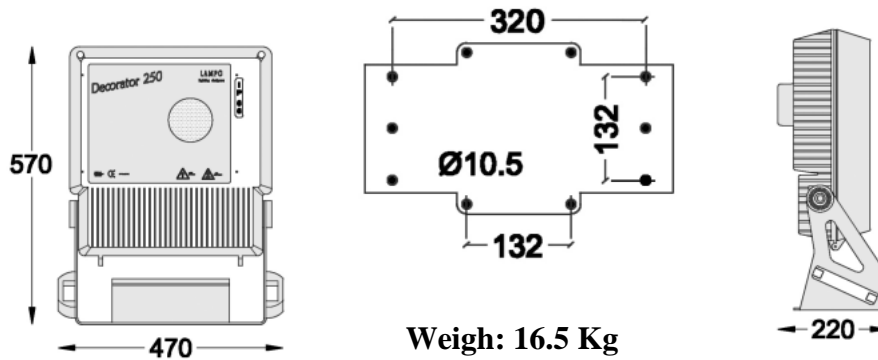

## Technical data

- Aluminium body with cooling fins, no fans
- Thermal-shock resistant glass
- Brackets for adjustable fixing
- MSD-250W (base Gy9.5) discharge lamp
- Magnetic ballast with power factor correction (1.8A max @ 230VAC with lamp ON)
- Innovative colour changing system R.B.G. (more colours combination)
- DMX controlled or STAND ALONE mode
- IP66 protection rate (not immersion)
- The projector can work in all position

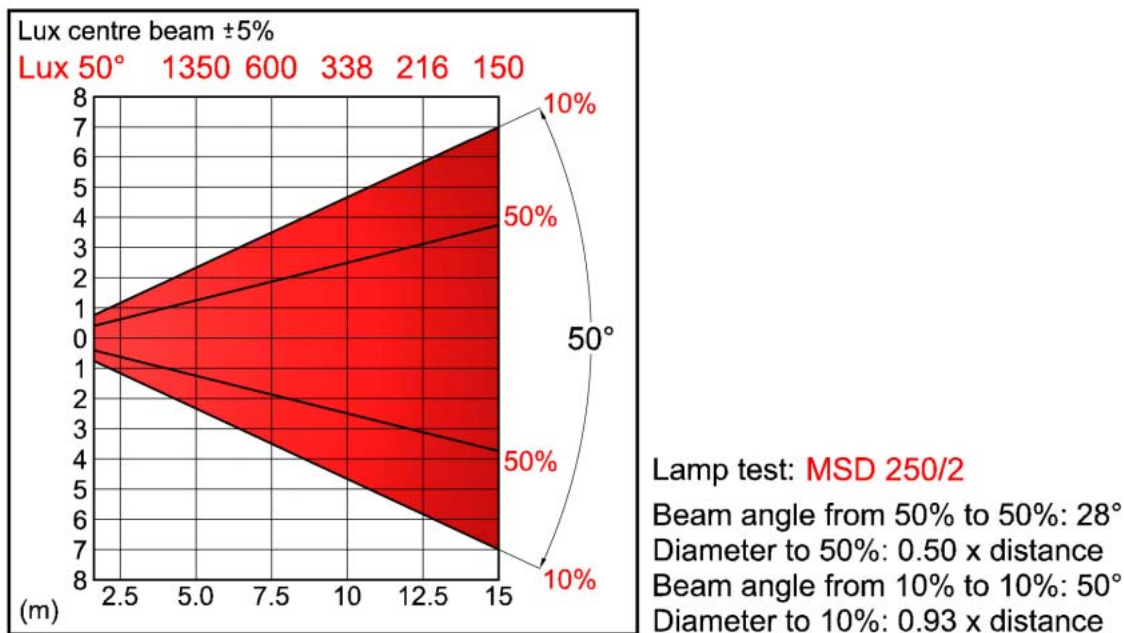

## Storage

The projector, in its original packing, must be kept in covered, dry areas with a temperature between  $-10^{\circ}\text{C}$  and  $+50^{\circ}\text{C}$ . Attention, the projector will be damaged during the unpacking.

## Admissible environmental conditions

The projector was engineered and produced to function in outdoor areas with an air temperature ranging between  $0^{\circ}$  and  $35^{\circ}\text{C}$  and with a humidity level between 30 and 90%.

When choosing the installation, please make sure that the device is not exposed to extreme heat or in small area.

## Power supply

Connect the fixture to the mains. See the table and the drawing for the colours of the connection cable.

PIN	SYMBOL	EC	US	UK
phase	L	brown	yellow/c	red
neutral	N	blue	silver	black
ground		yellow/green	green	green

Do not power the projector with a dimmer circuit

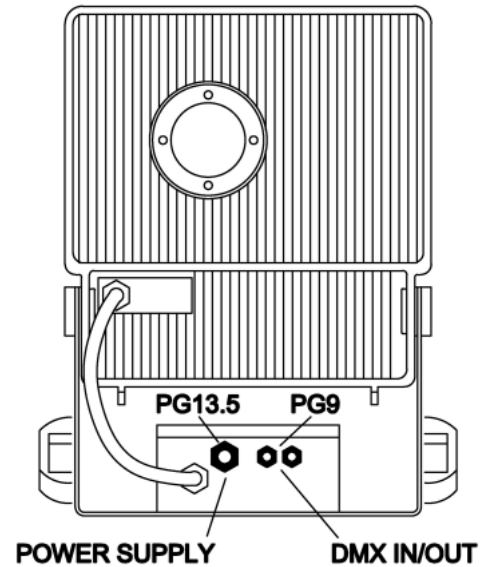
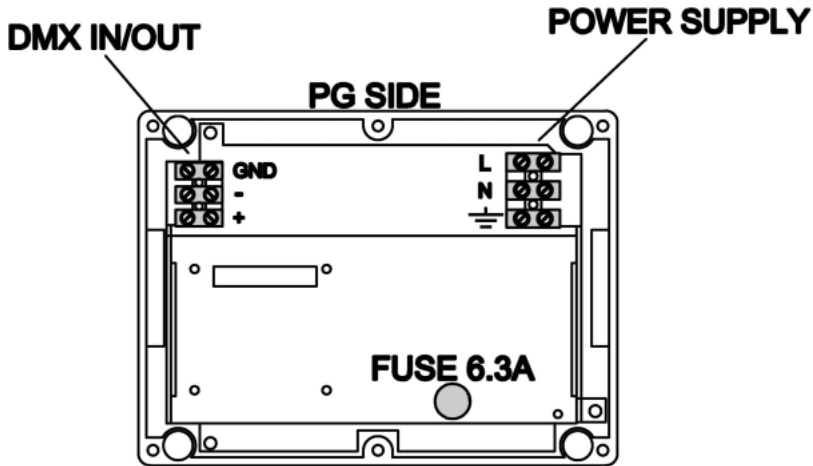

When in doubt, consult a qualified electrician.

The projector can be feed with voltage between 210Vac and 240Vac (on the projector body is specified if 50 or 60 Hz). Over-voltage caned damage the electronic parts of the projector or reduce the lamp life. It is advised to check the electric system before installation.

When the projector is switched on, the starting current is proxy double from the nominal current. After one minute the lamp has beam switched and the current absorbed goes down to 1.8A (230V).

The projector is completly grounded, it is necessary to connect the grounding system to the projector.

Protect the electric system with highly sensitive differential circuit breaker, 30mA.

The projector has in its inside a fuse, if a power failure should accur, that breake the power supply, if damage change it with a fuse of the same size.

Attention, the ignitor circuit inside the projector have a very high voltage, over 4.5KV.

## Example of connection

**Example 1:** The DMX signal is generated by a DMX controller, the signal cable goes in and out from each projector up to the last one.

The projectors will execute the same scenes if the DMX addresses are the same (factory set is 1) or they can be driven one by one if the DMX addresses are different from each other. (each projector uses 1 DMX channel):

**Projector 1: DMX address 1    Projector 2: DMX address 2    Projector 3: DMX address 3**

### EXAMPLE 1

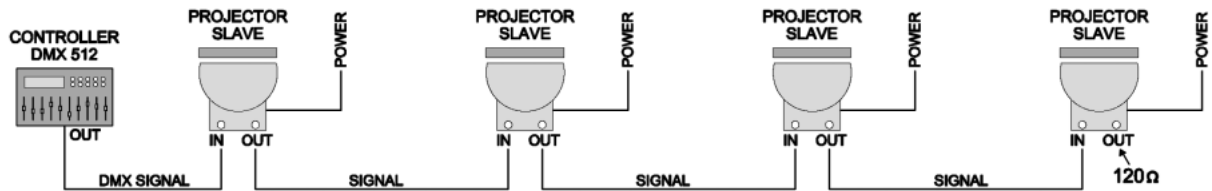

### EXAMPLE 2

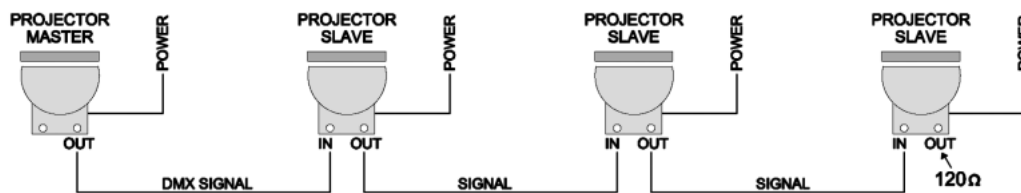

**Example 2:** The DMX signal is generated by a projector on stand alone mode (MASTER).

The projector MASTER will automatically execute scenes and it will drive the projector SLAVE of the same model.

In the two examples the projectors can be fed from different power sources, it is not necessary to switch on the projectors at the same time.

If the DMX controller or the MASTER projector is not switched on, the projectors will project white light.

## DMX signal cable

Use only shielded and twisted cables with EIA485 (RS485) standards. The cable must be low capacity and an impedance between 82 and 120 ohm.

It is preferable not to use audio cables.

We advise you to read the example of the following tables as a reference to use to correct cables.

### Cables with 1 pair of wires

Type	Cod.	AWG	Impedance (ohm)
BELDEN	1162A	20	100
BELDEN	8227	20	100
BELDEN	89207	20	100
ALPHA	9109	20	100
ALPHA	9817	20	100
ALPHA	9818	20	100

### Cables with 2 pairs of wires

Type	Cod.	AWG	Impedance (ohm)
BELDEN	8102	24	100
BELDEN	8162	24	100
BELDEN	89696	22	100
PROPLEX	PC224P	22	110
PROPLEX	PC224T	22	110

The wire size we recommended is 26 AWG or higher.

The external diameter of cable must be included between 4 and 7mm (PG9 cable clamps).

It is preferable:

- not to insert over 32 projectors each DMX chain
- not to use more than 150m of signal cable (with low quality cable)
- not to use more than 500m of signal cable (with good quality cable)

Standard DMX controllers have only one signal out-put. If more than 32 projectors are used it is necessary to have a signal SPLITTER, that will duplicate the signal in 2 or more lines.

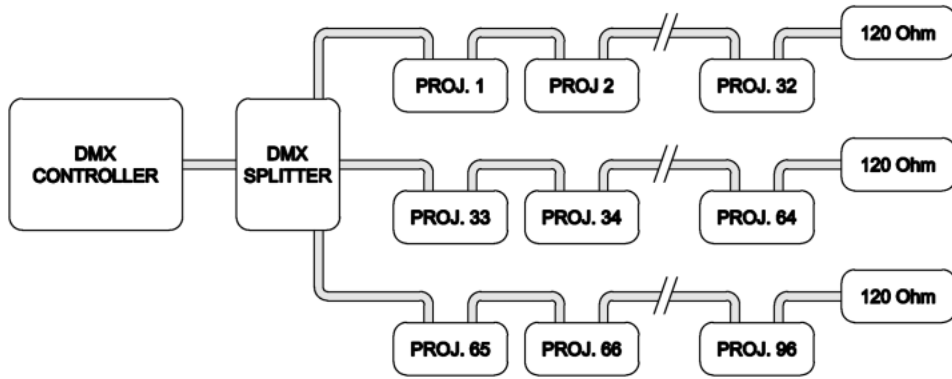

If the signal cable is very long, it is necessary to install a signal AMPLIFIER on the DMX line (at least every 500m of good quality cable), so that it will repeat the signal to the following projectors.

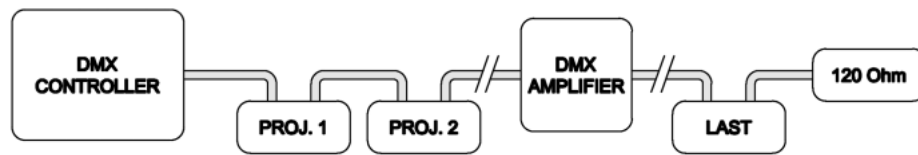

On the last projector of the signal chain it is necessary to insert a resistor (from 82 to 120 ohm) between positive and negative terminal (+ and -).

**DMX CONTROLLER OUT**

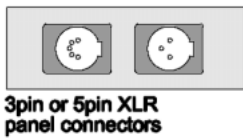

3pin or 5pin XLR panel connectors

3pin or 5pin XLR male

**LAST PROJECTOR**

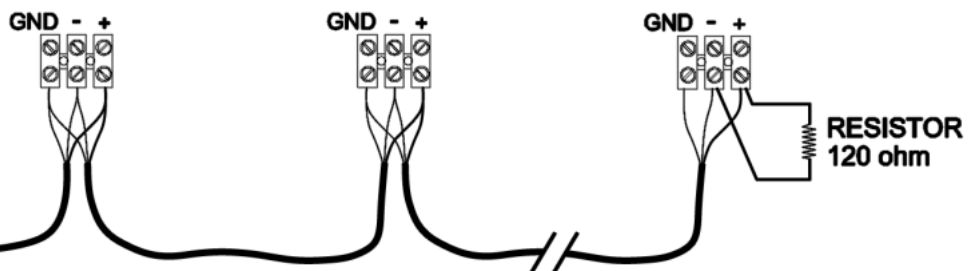

Use MALE XLR 3 or 5 pin connector to connect the projectors to the DMX controller.

Solder on PIN 1 of the XLR connector the shield of the signal cable, on PIN 2 solder the negative (example: black wire of cable) and on PIN 3 solder the positive (example: red or white wire of the cable).

The sequences and the colours has to be the same on the terminal blocks, do not change the sequences

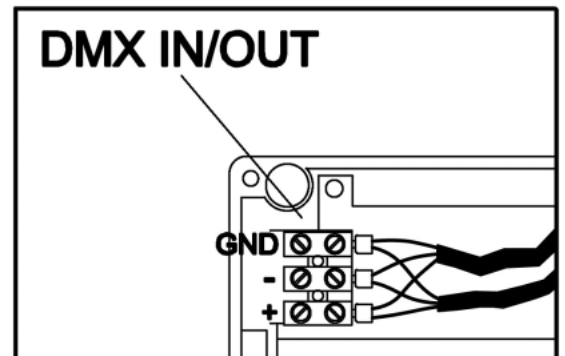
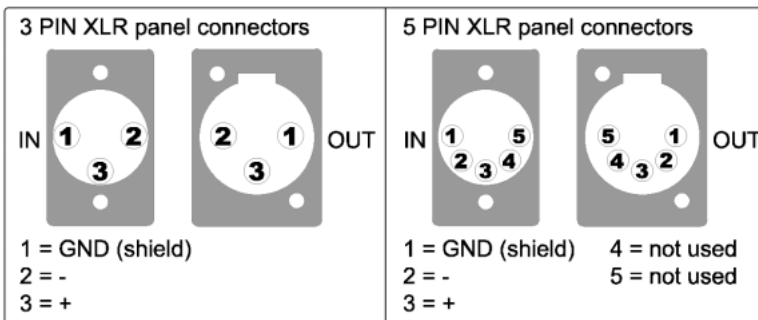

The IN and OUT signal cables must be connected directly to the terminal block inside the projector. Use the PG9 cable clamps on the projector).

## User's interface

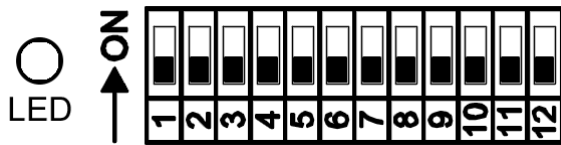

The LED lighted indicates the presence of DMX signal.  
The LED flashing indicates the absence of DMX signal.

To modify the DMX address and the settings, it is necessary to move the dip-switches on ON or OFF position, following the tables and the drawings of this manual.

## DMX512 specifications

The projector needs 1 DMX channel, from 0 to 255.

COLOURS	Values DMX
WHITE	0 .....
BLUE	..... 63.....
RED	..... 127.....
GREEN	..... 191 .....
BLUE	..... 255

The table shows the medium DMX values for the primary colours.  
These primary colours can vary from +5 to -5.

## DMX starting address

To pilot the projector with a DMX signal, it is necessary to assign a DMX address to the projector.

The projector is sold with DMX address set on 1. Only the dip-switch 1 is on ON.

To each dip-switch correspond a number, the sum of these values decides the first DMX channel of control.

DIP-SWITCH	Values DECIMAL
Dip 1	DMX add. (1)
Dip 2	DMX add. (2)
Dip 3	DMX add. (4)
Dip 4	DMX add. (8)
Dip 5	DMX add. (16)
Dip 6	DMX add. (32)
Dip 7	DMX add. (64)
Dip 8	DMX add. (128)
Dip 9	DMX add. (256)
Dip 10	Not used
Dip 11	Not used
Dip 12	<b>OFF</b>



For example, to set a projector on DMX starting address 39, you must set dip-switches values 32, 4, 2, and 1 to the ON position, because  $32+4+2+1=39$

To pilot the projector by any DMX controller or by projector in stand-alone mode (STAND ALONE/MASTER) set on OFF the dip-switches 12 (DMX/SLAVE).

Here following the dip-switches setting of each DMX address



DMX	Dip1	Dip2	Dip3	Dip4	Dip5	Dip6	Dip7	Dip8	Dip9
	off	off	off	off	off	off	off	off	off
1	ON	off	off	off	off	off	off	off	off
2	off	ON	off	off	off	off	off	off	off
3	ON	ON	off	off	off	off	off	off	off
4	off	off	ON	off	off	off	off	off	off
5	ON	off	ON	off	off	off	off	off	off
6	off	ON	ON	off	off	off	off	off	off
7	ON	ON	ON	off	off	off	off	off	off
8	off	off	off	ON	off	off	off	off	off
9	ON	off	off	ON	off	off	off	off	off
10	off	ON	off	ON	off	off	off	off	off
11	ON	ON	off	ON	off	off	off	off	off
12	off	off	ON	ON	off	off	off	off	off
13	ON	off	ON	ON	off	off	off	off	off
14	off	ON	ON	ON	off	off	off	off	off
15	ON	ON	ON	ON	off	off	off	off	off
16	off	off	off	off	ON	off	off	off	off
17	ON	off	off	off	ON	off	off	off	off
18	off	ON	off	off	ON	off	off	off	off
19	ON	ON	off	off	ON	off	off	off	off
20	off	off	ON	off	ON	off	off	off	off
21	ON	off	ON	off	ON	off	off	off	off
22	off	ON	ON	off	ON	off	off	off	off
23	ON	ON	ON	off	ON	off	off	off	off
24	off	off	off	ON	ON	off	off	off	off
25	ON	off	off	ON	ON	off	off	off	off
26	off	ON	off	ON	ON	off	off	off	off
27	ON	ON	off	ON	ON	off	off	off	off
28	off	off	ON	ON	ON	off	off	off	off
29	ON	off	ON	ON	ON	off	off	off	off
30	off	ON	ON	ON	ON	off	off	off	off
31	ON	ON	ON	ON	ON	off	off	off	off
32	off	off	off	off	off	ON	off	off	off
33	ON	off	off	off	off	ON	off	off	off
34	off	ON	off	off	off	ON	off	off	off
35	ON	ON	off	off	off	ON	off	off	off
36	off	off	ON	off	off	ON	off	off	off
37	ON	off	ON	off	off	ON	off	off	off
38	off	ON	ON	off	off	ON	off	off	off
39	ON	ON	ON	off	off	ON	off	off	off
40	off	off	off	ON	off	ON	off	off	off
41	ON	off	off	ON	off	ON	off	off	off
42	off	ON	off	ON	off	ON	off	off	off
43	ON	ON	off	ON	off	ON	off	off	off
44	off	off	ON	ON	off	ON	off	off	off
45	ON	off	ON	ON	off	ON	off	off	off
46	off	ON	ON	ON	off	ON	off	off	off
47	ON	ON	ON	ON	off	ON	off	off	off
48	off	off	off	off	ON	ON	off	off	off
49	ON	off	off	off	ON	ON	off	off	off
50	off	ON	off	off	ON	ON	off	off	off
51	ON	ON	off	off	ON	ON	off	off	off
52	off	off	ON	off	ON	ON	off	off	off
53	ON	off	ON	off	ON	ON	off	off	off
54	off	ON	ON	off	ON	ON	off	off	off
55	ON	ON	ON	off	ON	ON	off	off	off
56	off	off	off	ON	ON	ON	off	off	off
57	ON	off	off	ON	ON	ON	off	off	off
58	off	ON	off	ON	ON	ON	off	off	off
59	ON	ON	off	ON	ON	ON	off	off	off
60	off	off	ON	ON	ON	ON	off	off	off
61	ON	off	ON	ON	ON	ON	off	off	off
62	off	ON	ON	ON	ON	ON	off	off	off
63	ON	ON	ON	ON	ON	ON	off	off	off

DMX	Dip1	Dip2	Dip3	Dip4	Dip5	Dip6	Dip7	Dip8	Dip9
64	off	off	off	off	off	off	ON	off	off
65	ON	off	off	off	off	off	ON	off	off
66	off	ON	off	off	off	off	ON	off	off
67	ON	ON	off	off	off	off	ON	off	off
68	off	off	ON	off	off	off	ON	off	off
69	ON	off	ON	off	off	off	ON	off	off
70	off	ON	ON	off	off	off	ON	off	off
71	ON	ON	ON	off	off	off	ON	off	off
72	off	off	off	ON	off	off	ON	off	off
73	ON	off	off	ON	off	off	ON	off	off
74	off	ON	off	ON	off	off	ON	off	off
75	ON	ON	off	ON	off	off	ON	off	off
76	off	off	ON	ON	off	off	ON	off	off
77	ON	off	ON	ON	off	off	ON	off	off
78	off	ON	ON	ON	off	off	ON	off	off
79	ON	ON	ON	ON	off	off	ON	off	off
80	off	off	off	off	ON	off	ON	off	off
81	ON	off	off	off	ON	off	ON	off	off
82	off	ON	off	off	ON	off	ON	off	off
83	ON	ON	off	off	ON	off	ON	off	off
84	off	off	ON	off	ON	off	ON	off	off
85	ON	off	ON	off	ON	off	ON	off	off
86	off	ON	ON	off	ON	off	ON	off	off
87	ON	ON	ON	off	ON	off	ON	off	off
88	off	off	off	ON	ON	off	ON	off	off
89	ON	off	off	ON	ON	off	ON	off	off
90	off	ON	off	ON	ON	off	ON	off	off
91	ON	ON	off	ON	ON	off	ON	off	off
92	off	off	ON	ON	ON	off	ON	off	off
93	ON	off	ON	ON	ON	off	ON	off	off
94	off	ON	ON	ON	ON	off	ON	off	off
95	ON	ON	ON	ON	ON	off	ON	off	off
96	off	off	off	off	off	ON	ON	off	off
97	ON	off	off	off	off	ON	ON	off	off
98	off	ON	off	off	off	ON	ON	off	off
99	ON	ON	off	off	off	ON	ON	off	off
100	off	off	ON	off	off	ON	ON	off	off
101	ON	off	ON	off	off	ON	ON	off	off
102	off	ON	ON	off	off	ON	ON	off	off
103	ON	ON	ON	off	off	ON	ON	off	off
104	off	off	off	ON	off	ON	ON	off	off
105	ON	off	off	ON	off	ON	ON	off	off
106	off	ON	off	ON	off	ON	ON	off	off
107	ON	ON	off	ON	off	ON	ON	off	off
108	off	off	ON	ON	off	ON	ON	off	off
109	ON	off	ON	ON	off	ON	ON	off	off
110	off	ON	ON	ON	off	ON	ON	off	off
111	ON	ON	ON	ON	off	ON	ON	off	off
112	off	off	off	off	ON	ON	ON	off	off
113	ON	off	off	off	ON	ON	ON	off	off
114	off	ON	off	off	ON	ON	ON	off	off
115	ON	ON	off	off	ON	ON	ON	off	off
116	off	off	ON	off	ON	ON	ON	off	off
117	ON	off	ON	off	ON	ON	ON	off	off
118	off	ON	ON	off	ON	ON	ON	off	off
119	ON	ON	ON	off	ON	ON	ON	off	off
120	off	off	off	ON	ON	ON	ON	off	off
121	ON	off	off	ON	ON	ON	ON	off	off
122	off	ON	off	ON	ON	ON	ON	off	off
123	ON	ON	off	ON	ON	ON	ON	off	off
124	off	off	ON	ON	ON	ON	ON	off	off
125	ON	off	ON	ON	ON	ON	ON	off	off
126	off	ON	ON	ON	ON	ON	ON	off	off
127	ON	ON	ON	ON	ON	ON	ON	off	off

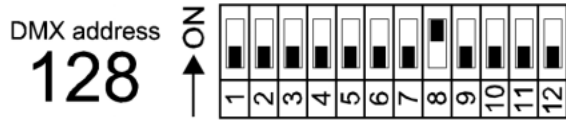

DMX	Dip1	Dip2	Dip3	Dip4	Dip5	Dip6	Dip7	Dip8	Dip9
128	off	off	off	off	off	off	off	ON	off
129	ON	off	off	off	off	off	off	ON	off
130	off	ON	off	off	off	off	off	ON	off
131	ON	ON	off	off	off	off	off	ON	off
132	off	off	ON	off	off	off	off	ON	off
133	ON	off	ON	off	off	off	off	ON	off
134	off	ON	ON	off	off	off	off	ON	off
135	ON	ON	ON	off	off	off	off	ON	off
136	off	off	off	ON	off	off	off	ON	off
137	ON	off	off	ON	off	off	off	ON	off
138	off	ON	off	ON	off	off	off	ON	off
139	ON	ON	off	ON	off	off	off	ON	off
140	off	off	ON	ON	off	off	off	ON	off
141	ON	off	ON	ON	off	off	off	ON	off
142	off	ON	ON	ON	off	off	off	ON	off
143	ON	ON	ON	ON	off	off	off	ON	off
144	off	off	off	off	ON	off	off	ON	off
145	ON	off	off	off	ON	off	off	ON	off
146	off	ON	off	off	ON	off	off	ON	off
147	ON	ON	off	off	ON	off	off	ON	off
148	off	off	ON	off	ON	off	off	ON	off
149	ON	off	ON	off	ON	off	off	ON	off
150	off	ON	ON	off	ON	off	off	ON	off
151	ON	ON	ON	off	ON	off	off	ON	off
152	off	off	off	ON	ON	off	off	ON	off
153	ON	off	off	ON	ON	off	off	ON	off
154	off	ON	off	ON	ON	off	off	ON	off
155	ON	ON	off	ON	ON	off	off	ON	off
156	off	off	ON	ON	ON	off	off	ON	off
157	ON	off	ON	ON	ON	off	off	ON	off
158	off	ON	ON	ON	ON	off	off	ON	off
159	ON	ON	ON	ON	ON	off	off	ON	off
160	off	off	off	off	off	ON	off	ON	off
161	ON	off	off	off	off	ON	off	ON	off
162	off	ON	off	off	off	ON	off	ON	off
163	ON	ON	off	off	off	ON	off	ON	off
164	off	off	ON	off	off	ON	off	ON	off
165	ON	off	ON	off	off	ON	off	ON	off
166	off	ON	ON	off	off	ON	off	ON	off
167	ON	ON	ON	off	off	ON	off	ON	off
168	off	off	off	ON	off	ON	off	ON	off
169	ON	off	off	ON	off	ON	off	ON	off
170	off	ON	off	ON	off	ON	off	ON	off
171	ON	ON	off	ON	off	ON	off	ON	off
172	off	off	ON	ON	off	ON	off	ON	off
173	ON	off	ON	ON	off	ON	off	ON	off
174	off	ON	ON	ON	off	ON	off	ON	off
175	ON	ON	ON	ON	off	ON	off	ON	off
176	off	off	off	off	ON	ON	off	ON	off
177	ON	off	off	off	ON	ON	off	ON	off
178	off	ON	off	off	ON	ON	off	ON	off
179	ON	ON	off	off	ON	ON	off	ON	off
180	off	off	ON	off	ON	ON	off	ON	off
181	ON	off	ON	off	ON	ON	off	ON	off
182	off	ON	ON	off	ON	ON	off	ON	off
183	ON	ON	ON	off	ON	ON	off	ON	off
184	off	off	off	ON	ON	ON	off	ON	off
185	ON	off	off	ON	ON	ON	off	ON	off
186	off	ON	off	ON	ON	ON	off	ON	off
187	ON	ON	off	ON	ON	ON	off	ON	off
188	off	off	ON	ON	ON	ON	off	ON	off
189	ON	off	ON	ON	ON	ON	off	ON	off
190	off	ON	ON	ON	ON	ON	off	ON	off
191	ON	ON	ON	ON	ON	ON	off	ON	off

DMX	Dip1	Dip2	Dip3	Dip4	Dip5	Dip6	Dip7	Dip8	Dip9
192	off	off	off	off	off	off	ON	ON	off
193	ON	off	off	off	off	off	ON	ON	off
194	off	ON	off	off	off	off	ON	ON	off
195	ON	ON	off	off	off	off	ON	ON	off
196	off	off	ON	off	off	off	ON	ON	off
197	ON	off	ON	off	off	off	ON	ON	off
198	off	ON	ON	off	off	off	ON	ON	off
199	ON	ON	ON	off	off	off	ON	ON	off
200	off	off	off	ON	off	off	ON	ON	off
201	ON	off	off	ON	off	off	ON	ON	off
202	off	ON	off	ON	off	off	ON	ON	off
203	ON	ON	off	ON	off	off	ON	ON	off
204	off	off	ON	ON	off	off	ON	ON	off
205	ON	off	ON	ON	off	off	ON	ON	off
206	off	ON	ON	ON	off	off	ON	ON	off
207	ON	ON	ON	ON	off	off	ON	ON	off
208	off	off	off	off	ON	off	ON	ON	off
209	ON	off	off	off	ON	off	ON	ON	off
210	off	ON	off	off	ON	off	ON	ON	off
211	ON	ON	off	off	ON	off	ON	ON	off
212	off	off	ON	off	ON	off	ON	ON	off
213	ON	off	ON	off	ON	off	ON	ON	off
214	off	ON	ON	off	ON	off	ON	ON	off
215	ON	ON	ON	off	ON	off	ON	ON	off
216	off	off	off	ON	ON	off	ON	ON	off
217	ON	off	off	ON	ON	off	ON	ON	off
218	off	ON	off	ON	ON	off	ON	ON	off
219	ON	ON	off	ON	ON	off	ON	ON	off
220	off	off	ON	ON	ON	off	ON	ON	off
221	ON	off	ON	ON	ON	off	ON	ON	off
222	off	ON	ON	ON	ON	off	ON	ON	off
223	ON	ON	ON	ON	ON	off	ON	ON	off
224	off	off	off	off	off	ON	ON	ON	off
225	ON	off	off	off	off	ON	ON	ON	off
226	off	ON	off	off	off	ON	ON	ON	off
227	ON	ON	off	off	off	ON	ON	ON	off
228	off	off	ON	off	off	ON	ON	ON	off
229	ON	off	ON	off	off	ON	ON	ON	off
230	off	ON	ON	off	off	ON	ON	ON	off
231	ON	ON	ON	off	off	ON	ON	ON	off
232	off	off	off	ON	off	ON	ON	ON	off
233	ON	off	off	ON	off	ON	ON	ON	off
234	off	ON	off	ON	off	ON	ON	ON	off
235	ON	ON	off	ON	off	ON	ON	ON	off
236	off	off	ON	ON	off	ON	ON	ON	off
237	ON	off	ON	ON	off	ON	ON	ON	off
238	off	ON	ON	ON	off	ON	ON	ON	off
239	ON	ON	ON	ON	off	ON	ON	ON	off
240	off	off	off	off	ON	ON	ON	ON	off
241	ON	off	off	off	ON	ON	ON	ON	off
242	off	ON	off	off	ON	ON	ON	ON	off
243	ON	ON	off	off	ON	ON	ON	ON	off
244	off	off	ON	off	ON	ON	ON	ON	off
245	ON	off	ON	off	ON	ON	ON	ON	off
246	off	ON	ON	off	ON	ON	ON	ON	off
247	ON	ON	ON	off	ON	ON	ON	ON	off
248	off	off	off	ON	ON	ON	ON	ON	off
249	ON	off	off	ON	ON	ON	ON	ON	off
250	off	ON	off	ON	ON	ON	ON	ON	off
251	ON	ON	off	ON	ON	ON	ON	ON	off
252	off	off	ON	ON	ON	ON	ON	ON	off
253	ON	off	ON	ON	ON	ON	ON	ON	off
254	off	ON	ON	ON	ON	ON	ON	ON	off
255	ON	ON	ON	ON	ON	ON	ON	ON	off

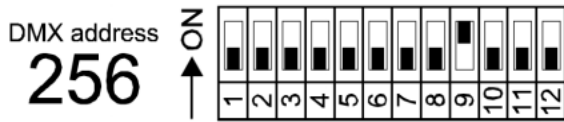

DMX	Dip1	Dip2	Dip3	Dip4	Dip5	Dip6	Dip7	Dip8	Dip9
256	off	off	off	off	off	off	off	off	ON
257	ON	off	off	off	off	off	off	off	ON
258	off	ON	off	off	off	off	off	off	ON
259	ON	ON	off	off	off	off	off	off	ON
260	off	off	ON	off	off	off	off	off	ON
261	ON	off	ON	off	off	off	off	off	ON
262	off	ON	ON	off	off	off	off	off	ON
263	ON	ON	ON	off	off	off	off	off	ON
264	off	off	off	ON	off	off	off	off	ON
265	ON	off	off	ON	off	off	off	off	ON
266	off	ON	off	ON	off	off	off	off	ON
267	ON	ON	off	ON	off	off	off	off	ON
268	off	off	ON	ON	off	off	off	off	ON
269	ON	off	ON	ON	off	off	off	off	ON
270	off	ON	ON	ON	off	off	off	off	ON
271	ON	ON	ON	ON	off	off	off	off	ON
272	off	off	off	off	ON	off	off	off	ON
273	ON	off	off	off	ON	off	off	off	ON
274	off	ON	off	off	ON	off	off	off	ON
275	ON	ON	off	off	ON	off	off	off	ON
276	off	off	ON	off	ON	off	off	off	ON
277	ON	off	ON	off	ON	off	off	off	ON
278	off	ON	ON	off	ON	off	off	off	ON
279	ON	ON	ON	off	ON	off	off	off	ON
280	off	off	off	ON	ON	off	off	off	ON
281	ON	off	off	ON	ON	off	off	off	ON
282	off	ON	off	ON	ON	off	off	off	ON
283	ON	ON	off	ON	ON	off	off	off	ON
284	off	off	ON	ON	ON	off	off	off	ON
285	ON	off	ON	ON	ON	off	off	off	ON
286	off	ON	ON	ON	ON	off	off	off	ON
287	ON	ON	ON	ON	ON	off	off	off	ON
288	off	off	off	off	off	ON	off	off	ON
289	ON	off	off	off	off	ON	off	off	ON
290	off	ON	off	off	off	ON	off	off	ON
291	ON	ON	off	off	off	ON	off	off	ON
292	off	off	ON	off	off	ON	off	off	ON
293	ON	off	ON	off	off	ON	off	off	ON
294	off	ON	ON	off	off	ON	off	off	ON
295	ON	ON	ON	off	off	ON	off	off	ON
296	off	off	off	ON	off	ON	off	off	ON
297	ON	off	off	ON	off	ON	off	off	ON
298	off	ON	off	ON	off	ON	off	off	ON
299	ON	ON	off	ON	off	ON	off	off	ON
300	off	off	ON	ON	off	ON	off	off	ON
301	ON	off	ON	ON	off	ON	off	off	ON
302	off	ON	ON	ON	off	ON	off	off	ON
303	ON	ON	ON	ON	off	ON	off	off	ON
304	off	off	off	off	ON	ON	off	off	ON
305	ON	off	off	off	ON	ON	off	off	ON
306	off	ON	off	off	ON	ON	off	off	ON
307	ON	ON	off	off	ON	ON	off	off	ON
308	off	off	ON	off	ON	ON	off	off	ON
309	ON	off	ON	off	ON	ON	off	off	ON
310	off	ON	ON	off	ON	ON	off	off	ON
311	ON	ON	ON	off	ON	ON	off	off	ON
312	off	off	off	ON	ON	ON	off	off	ON
313	ON	off	off	ON	ON	ON	off	off	ON
314	off	ON	off	ON	ON	ON	off	off	ON
315	ON	ON	off	ON	ON	ON	off	off	ON
316	off	off	ON	ON	ON	ON	off	off	ON
317	ON	off	ON	ON	ON	ON	off	off	ON
318	off	ON	ON	ON	ON	ON	off	off	ON
319	ON	ON	ON	ON	ON	ON	off	off	ON

DMX	Dip1	Dip2	Dip3	Dip4	Dip5	Dip6	Dip7	Dip8	Dip9
320	off	off	off	off	off	off	ON	off	ON
321	ON	off	off	off	off	off	ON	off	ON
322	off	ON	off	off	off	off	ON	off	ON
323	ON	ON	off	off	off	off	ON	off	ON
324	off	off	ON	off	off	off	ON	off	ON
325	ON	off	ON	off	off	off	ON	off	ON
326	off	ON	ON	off	off	off	ON	off	ON
327	ON	ON	ON	off	off	off	ON	off	ON
328	off	off	off	ON	off	off	ON	off	ON
329	ON	off	off	ON	off	off	ON	off	ON
330	off	ON	off	ON	off	off	ON	off	ON
331	ON	ON	off	ON	off	off	ON	off	ON
332	off	off	ON	ON	off	off	ON	off	ON
333	ON	off	ON	ON	off	off	ON	off	ON
334	off	ON	ON	ON	off	off	ON	off	ON
335	ON	ON	ON	ON	off	off	ON	off	ON
336	off	off	off	off	ON	off	ON	off	ON
337	ON	off	off	off	ON	off	ON	off	ON
338	off	ON	off	off	ON	off	ON	off	ON
339	ON	ON	off	off	ON	off	ON	off	ON
340	off	off	ON	off	ON	off	ON	off	ON
341	ON	off	ON	off	ON	off	ON	off	ON
342	off	ON	ON	off	ON	off	ON	off	ON
343	ON	ON	ON	off	ON	off	ON	off	ON
344	off	off	off	ON	ON	off	ON	off	ON
345	ON	off	off	ON	ON	off	ON	off	ON
346	off	ON	off	ON	ON	off	ON	off	ON
347	ON	ON	off	ON	ON	off	ON	off	ON
348	off	off	ON	ON	ON	off	ON	off	ON
349	ON	off	ON	ON	ON	off	ON	off	ON
350	off	ON	ON	ON	ON	off	ON	off	ON
351	ON	ON	ON	ON	ON	off	ON	off	ON
352	off	off	off	off	off	ON	ON	off	ON
353	ON	off	off	off	off	ON	ON	off	ON
354	off	ON	off	off	off	ON	ON	off	ON
355	ON	ON	off	off	off	ON	ON	off	ON
356	off	off	ON	off	off	ON	ON	off	ON
357	ON	off	ON	off	off	ON	ON	off	ON
358	off	ON	ON	off	off	ON	ON	off	ON
359	ON	ON	ON	off	off	ON	ON	off	ON
360	off	off	off	ON	off	ON	ON	off	ON
361	ON	off	off	ON	off	ON	ON	off	ON
362	off	ON	off	ON	off	ON	ON	off	ON
363	ON	ON	off	ON	off	ON	ON	off	ON
364	off	off	ON	ON	off	ON	ON	off	ON
365	ON	off	ON	ON	off	ON	ON	off	ON
366	off	ON	ON	ON	off	ON	ON	off	ON
367	ON	ON	ON	ON	off	ON	ON	off	ON
368	off	off	off	off	ON	ON	ON	off	ON
369	ON	off	off	off	ON	ON	ON	off	ON
370	off	ON	off	off	ON	ON	ON	off	ON
371	ON	ON	off	off	ON	ON	ON	off	ON
372	off	off	ON	off	ON	ON	ON	off	ON
373	ON	off	ON	off	ON	ON	ON	off	ON
374	off	ON	ON	off	ON	ON	ON	off	ON
375	ON	ON	ON	off	ON	ON	ON	off	ON
376	off	off	off	ON	ON	ON	ON	off	ON
377	ON	off	off	ON	ON	ON	ON	off	ON
378	off	ON	off	ON	ON	ON	ON	off	ON
379	ON	ON	off	ON	ON	ON	ON	off	ON
380	off	off	ON	ON	ON	ON	ON	off	ON
381	ON	off	ON	ON	ON	ON	ON	off	ON
382	off	ON	ON	ON	ON	ON	ON	off	ON
383	ON	ON	ON	ON	ON	ON	ON	off	ON

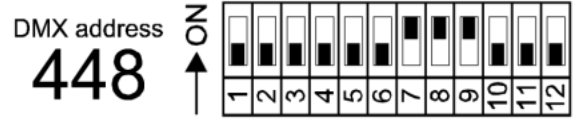
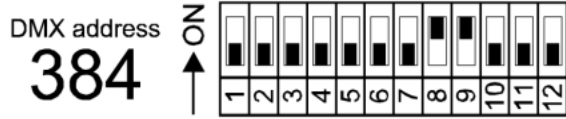

DMX	Dip1	Dip2	Dip3	Dip4	Dip5	Dip6	Dip7	Dip8	Dip9
384	off	off	off	off	off	off	off	ON	ON
385	ON	off	off	off	off	off	off	ON	ON
386	off	ON	off	off	off	off	off	ON	ON
387	ON	ON	off	off	off	off	off	ON	ON
388	off	off	ON	off	off	off	off	ON	ON
389	ON	off	ON	off	off	off	off	ON	ON
390	off	ON	ON	off	off	off	off	ON	ON
391	ON	ON	ON	off	off	off	off	ON	ON
392	off	off	off	ON	off	off	off	ON	ON
393	ON	off	off	ON	off	off	off	ON	ON
394	off	ON	off	ON	off	off	off	ON	ON
395	ON	ON	off	ON	off	off	off	ON	ON
396	off	off	ON	ON	off	off	off	ON	ON
397	ON	off	ON	ON	off	off	off	ON	ON
398	off	ON	ON	ON	off	off	off	ON	ON
399	ON	ON	ON	ON	off	off	off	ON	ON
400	off	off	off	off	ON	off	off	ON	ON
401	ON	off	off	off	ON	off	off	ON	ON
402	off	ON	off	off	ON	off	off	ON	ON
403	ON	ON	off	off	ON	off	off	ON	ON
404	off	off	ON	off	ON	off	off	ON	ON
405	ON	off	ON	off	ON	off	off	ON	ON
406	off	ON	ON	off	ON	off	off	ON	ON
407	ON	ON	ON	off	ON	off	off	ON	ON
408	off	off	off	ON	ON	off	off	ON	ON
409	ON	off	off	ON	ON	off	off	ON	ON
410	off	ON	off	ON	ON	off	off	ON	ON
411	ON	ON	off	ON	ON	off	off	ON	ON
412	off	off	ON	ON	ON	off	off	ON	ON
413	ON	off	ON	ON	ON	off	off	ON	ON
414	off	ON	ON	ON	ON	off	off	ON	ON
415	ON	ON	ON	ON	ON	off	off	ON	ON
416	off	off	off	off	off	ON	off	ON	ON
417	ON	off	off	off	off	ON	off	ON	ON
418	off	ON	off	off	off	ON	off	ON	ON
419	ON	ON	off	off	off	ON	off	ON	ON
420	off	off	ON	off	off	ON	off	ON	ON
421	ON	off	ON	off	off	ON	off	ON	ON
422	off	ON	ON	off	off	ON	off	ON	ON
423	ON	ON	ON	off	off	ON	off	ON	ON
424	off	off	off	ON	off	ON	off	ON	ON
425	ON	off	off	ON	off	ON	off	ON	ON
426	off	ON	off	ON	off	ON	off	ON	ON
427	ON	ON	off	ON	off	ON	off	ON	ON
428	off	off	ON	ON	off	ON	off	ON	ON
429	ON	off	ON	ON	off	ON	off	ON	ON
430	off	ON	ON	ON	off	ON	off	ON	ON
431	ON	ON	ON	ON	off	ON	off	ON	ON
432	off	off	off	off	ON	ON	off	ON	ON
433	ON	off	off	off	ON	ON	off	ON	ON
434	off	ON	off	off	ON	ON	off	ON	ON
435	ON	ON	off	off	ON	ON	off	ON	ON
436	off	off	ON	off	ON	ON	off	ON	ON
437	ON	off	ON	off	ON	ON	off	ON	ON
438	off	ON	ON	off	ON	ON	off	ON	ON
439	ON	ON	ON	off	ON	ON	off	ON	ON
440	off	off	off	ON	ON	ON	off	ON	ON
441	ON	off	off	ON	ON	ON	off	ON	ON
442	off	ON	off	ON	ON	ON	off	ON	ON
443	ON	ON	off	ON	ON	ON	off	ON	ON
444	off	off	ON	ON	ON	ON	off	ON	ON
445	ON	off	ON	ON	ON	ON	off	ON	ON
446	off	ON	ON	ON	ON	ON	off	ON	ON
447	ON	ON	ON	ON	ON	ON	off	ON	ON

DMX	Dip1	Dip2	Dip3	Dip4	Dip5	Dip6	Dip7	Dip8	Dip9
448	off	off	off	off	off	off	ON	ON	ON
449	ON	off	off	off	off	off	ON	ON	ON
450	off	ON	off	off	off	off	ON	ON	ON
451	ON	ON	off	off	off	off	ON	ON	ON
452	off	off	ON	off	off	off	ON	ON	ON
453	ON	off	ON	off	off	off	ON	ON	ON
454	off	ON	ON	off	off	off	ON	ON	ON
455	ON	ON	ON	off	off	off	ON	ON	ON
456	off	off	off	ON	off	off	ON	ON	ON
457	ON	off	off	ON	off	off	ON	ON	ON
458	off	ON	off	ON	off	off	ON	ON	ON
459	ON	ON	off	ON	off	off	ON	ON	ON
460	off	off	ON	ON	off	off	ON	ON	ON
461	ON	off	ON	ON	off	off	ON	ON	ON
462	off	ON	ON	ON	off	off	ON	ON	ON
463	ON	ON	ON	ON	off	off	ON	ON	ON
464	off	off	off	off	ON	off	ON	ON	ON
465	ON	off	off	off	ON	off	ON	ON	ON
466	off	ON	off	off	ON	off	ON	ON	ON
467	ON	ON	off	off	ON	off	ON	ON	ON
468	off	off	ON	off	ON	off	ON	ON	ON
469	ON	off	ON	off	ON	off	ON	ON	ON
470	off	ON	ON	off	ON	off	ON	ON	ON
471	ON	ON	ON	off	ON	off	ON	ON	ON
472	off	off	off	ON	ON	off	ON	ON	ON
473	ON	off	off	ON	ON	off	ON	ON	ON
474	off	ON	off	ON	ON	off	ON	ON	ON
475	ON	ON	off	ON	ON	off	ON	ON	ON
476	off	off	ON	ON	ON	off	ON	ON	ON
477	ON	off	ON	ON	ON	off	ON	ON	ON
478	off	ON	ON	ON	ON	off	ON	ON	ON
479	ON	ON	ON	ON	ON	off	ON	ON	ON
480	off	off	off	off	off	ON	ON	ON	ON
481	ON	off	off	off	off	ON	ON	ON	ON
482	off	ON	off	off	off	ON	ON	ON	ON
483	ON	ON	off	off	off	ON	ON	ON	ON
484	off	off	ON	off	off	ON	ON	ON	ON
485	ON	off	ON	off	off	ON	ON	ON	ON
486	off	ON	ON	off	off	ON	ON	ON	ON
487	ON	ON	ON	off	off	ON	ON	ON	ON
488	off	off	off	ON	off	ON	ON	ON	ON
489	ON	off	off	ON	off	ON	ON	ON	ON
490	off	ON	off	ON	off	ON	ON	ON	ON
491	ON	ON	off	ON	off	ON	ON	ON	ON
492	off	off	ON	ON	off	ON	ON	ON	ON
493	ON	off	ON	ON	off	ON	ON	ON	ON
494	off	ON	ON	ON	off	ON	ON	ON	ON
495	ON	ON	ON	ON	off	ON	ON	ON	ON
496	off	off	off	off	ON	ON	ON	ON	ON
497	ON	off	off	off	ON	ON	ON	ON	ON
498	off	ON	off	off	ON	ON	ON	ON	ON
499	ON	ON	off	off	ON	ON	ON	ON	ON
500	off	off	ON	off	ON	ON	ON	ON	ON
501	ON	off	ON	off	ON	ON	ON	ON	ON
502	off	ON	ON	off	ON	ON	ON	ON	ON
503	ON	ON	ON	off	ON	ON	ON	ON	ON
504	off	off	off	ON	ON	ON	ON	ON	ON
505	ON	off	off	ON	ON	ON	ON	ON	ON
506	off	ON	off	ON	ON	ON	ON	ON	ON
507	ON	ON	off	ON	ON	ON	ON	ON	ON
508	off	off	ON	ON	ON	ON	ON	ON	ON
509	ON	off	ON	ON	ON	ON	ON	ON	ON
510	off	ON	ON	ON	ON	ON	ON	ON	ON
511	ON	ON	ON	ON	ON	ON	ON	ON	ON

## Stand alone mode (colour sequences)

For the stand alone mode (STAND ALONE/MASTER), the dip-switch 12 has to be on the ON position. When the projector is switched on, it will execute the functions set on the dip-switches.

If the projector has to execute colour sequences, the dip-switches 4 has to be on OFF position.

**WARNING: The projector in stand alone mode becomes a DMX generator, it is necessary to disconnect that projector by DMX controller or by the other projector MASTER because generates conflict in the signal.**

Setting the dip-switches 1, 2, 3, it is possible to choose the colour sequence that the projector will execute.

Setting the dip-switches 5, 6, 7, it is possible to choose the colour changing time between two colours.

Setting the dip-switches 8, 9, 10, 11, it is possible to choose the colour holding time for each colour.

DIP-SWITCH	FUNCTION
Dip 1	MODE 1
Dip 2	MODE 2
Dip 3	MODE 3
Dip 4	<b>OFF</b>
Dip 5	CHANGING TIME 1
Dip 6	CHANGING TIME 2
Dip 7	CHANGING TIME 3
Dip 8	HOLD TIME 1
Dip 9	HOLD TIME 2
Dip 10	HOLD TIME 3
Dip 11	HOLD TIME 4
Dip 12	<b>ON</b>

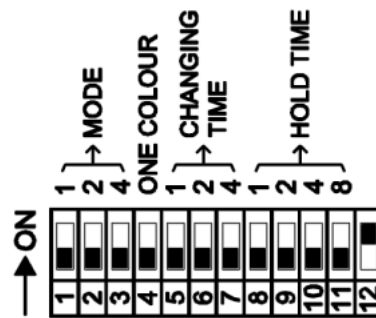

## COLOR SEQUENCE SETTING

As shown in the following table the projector will execute the colour from top to bottom and back.

Dip 1	off	ON	off	ON	off	ON	off	ON
Dip 2	off	off	ON	ON	off	off	ON	ON
Dip 3	off	off	off	off	ON	ON	ON	ON
Color sequence	White	Azurre	Azurre	Yellow	Azurre	Magenta	White	White
	Blue	Blue	Orange	Orange	Red	Yellow	Red	Blue
	Magenta	Orange	Light green	Magenta	Green	Azurre	Green	Red
	Red	Cyan	Dark green	Violet				
	Yellow							
	Green							
	Cyan							

## COLOUR CHANGING TIME SETTING

Setting the dip-switches 5, 6, 7, it is possible to choose the color changing time between two colours.

Dip 5	Dip 6	Dip 7	Seconds
off	off	off	1
ON	off	off	5
off	ON	off	10
ON	ON	off	20
off	off	ON	40
ON	off	ON	60
off	ON	ON	120
ON	ON	ON	240

## COLOUR HOLDING TIME SETTING

Setting the dip-switches 8, 9, 10, 11, it is possible to choose the colour holding time (from 1 second to 8 hours).

Dip 8	Dip 9	Dip 10	Dip 11	Seconds
off	off	off	off	1
ON	off	off	off	5
off	ON	off	off	10
ON	ON	off	off	20
off	off	ON	off	30

Dip 8	Dip 9	Dip 10	Dip 11	Minutes
ON	off	ON	off	1
off	ON	ON	off	2
ON	ON	ON	off	5
off	off	off	ON	10
ON	off	off	ON	15
off	ON	off	ON	30

Dip 8	Dip 9	Dip 10	Dip 11	Hours
ON	ON	off	ON	1
off	off	ON	ON	2
ON	off	ON	ON	4
off	ON	ON	ON	6
ON	ON	ON	ON	8

## Stand alone mode (one fixed colour)

For the stand alone mode (STAND ALONE/MASTER), the dip-switch 12 has to be on the ON position. When the projector is switched on, it will execute the functions set on the dip-switches.

If the projector has to execute one fixed colour, the dip-switch 4 has to be on ON position.

**WARNING: The projector in stand alone mode becomes a DMX generator, it is necessary to disconnect that projector by DMX controller or by the other projector MASTER because generates conflict in the signal.**

Setting the dip-switches 5, 6, 7, 8, 9, 10, 11 it is possible to choose the fixed colour to project.

DIP-SWITCH	VALUES
Dip 1	Not used
Dip 2	Not used
Dip 3	Not used
Dip 4	ON
Dip 5	1
Dip 6	2
Dip 7	4
Dip 8	8
Dip 9	16
Dip 10	32
Dip 11	64
Dip 12	ON

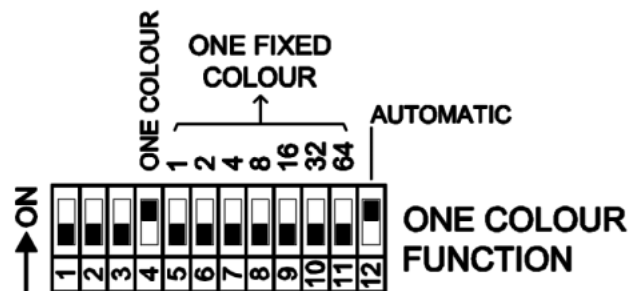

# ONE FIXED COLOUR SELECTION

The dip-switches assign the fixed colour, see the table, Dip-switches 4 and 12 in ON position.

Dip 5	Dip 6	Dip 7	Dip 8	Dip 9	Dip 10	Dip 11	COLOUR	Values	
off	off	off	off	off	off	off	WHITE	0	
ON	off	off	off	off	off	off	Shading from WHITE to BLUE	1	
off	ON	off	off	off	off	off		2	
ON	ON	off	off	off	off	off		3	
off	off	ON	off	off	off	off		4	
ON	off	ON	off	off	off	off		5	
off	ON	ON	off	off	off	off		6	
ON	ON	ON	off	off	off	off		7	
off	off	off	ON	off	off	off		8	
ON	off	off	ON	off	off	off		9	
off	ON	off	ON	off	off	off		10	
ON	ON	off	ON	off	off	off		11	
off	off	ON	ON	off	off	off		12	
ON	off	ON	ON	off	off	off		13	
off	ON	ON	ON	off	off	off		14	
ON	ON	ON	ON	off	off	off		15	
off	off	off	off	ON	off	off		16	
ON	off	off	off	ON	off	off		17	
off	ON	off	off	ON	off	off	BLUE	18	
ON	ON	off	off	ON	off	off	Shading from BLUE to MAGENTA	19	
off	off	ON	off	ON	off	off		20	
ON	off	ON	off	ON	off	off		21	
off	ON	ON	off	ON	off	off		22	
ON	ON	ON	off	ON	off	off		23	
off	off	off	ON	ON	off	off		24	
ON	off	off	ON	ON	off	off		25	
off	ON	off	ON	ON	off	off		26	
ON	ON	off	ON	ON	off	off		27	
off	off	ON	ON	ON	off	off		28	
ON	off	ON	ON	ON	off	off		29	
off	ON	ON	ON	ON	off	off		30	
ON	ON	ON	ON	ON	off	off		31	
off	off	off	off	off	ON	off		32	
ON	off	off	off	off	ON	off		33	
off	ON	off	off	off	ON	off		34	
ON	ON	off	off	off	ON	off		35	
off	off	ON	off	off	ON	off	MAGENTA	36	
ON	off	ON	off	off	ON	off	Shading from MAGENTA to RED	37	
off	ON	ON	off	off	ON	off		38	
ON	ON	ON	off	off	ON	off		39	
off	off	off	ON	off	ON	off		40	
ON	off	off	ON	off	ON	off		41	
off	ON	off	ON	off	ON	off		42	
ON	ON	off	ON	off	ON	off		43	
off	off	ON	ON	off	ON	off		44	
ON	off	ON	ON	off	ON	off		45	
off	ON	ON	ON	off	ON	off		46	
ON	ON	ON	ON	off	ON	off		47	
off	off	off	off	ON	ON	off		48	
ON	off	off	off	ON	ON	off		49	
off	ON	off	off	ON	ON	off		50	
ON	ON	off	off	ON	ON	off		51	
off	off	ON	off	ON	ON	off		52	
ON	off	ON	off	ON	ON	off		53	
off	ON	ON	off	ON	ON	off	RED	54	
ON	ON	ON	off	ON	ON	off	Shading from RED to YELLOW	55	
off	off	off	ON	ON	ON	off		56	
ON	off	off	ON	ON	ON	off		57	
off	ON	off	ON	ON	ON	off		58	
ON	ON	off	ON	ON	ON	off		59	
off	off	ON	ON	ON	ON	off		60	
ON	off	ON	ON	ON	ON	off		61	
off	ON	ON	ON	ON	ON	off		62	
ON	ON	ON	ON	ON	ON	off		63	
off	off	off	off	off	off	ON		Shading from YELLOW to GREEN	64
ON	off	off	off	off	off	ON			65
off	ON	off	off	off	off	ON			66
ON	ON	off	off	off	off	ON			67
off	off	ON	off	off	off	ON			68
ON	off	ON	off	off	off	ON			69
off	ON	ON	off	off	off	ON			70
ON	ON	ON	off	off	off	ON			71
off	off	off	ON	off	off	ON	YELLOW		72
ON	off	off	ON	off	off	ON	Shading from YELLOW to GREEN		73
off	ON	off	ON	off	off	ON			74
ON	ON	off	ON	off	off	ON			75
off	off	ON	ON	off	off	ON			76
ON	off	ON	ON	off	off	ON			77
off	ON	ON	ON	off	off	ON			78
ON	ON	ON	ON	off	off	ON			79
off	off	off	off	ON	off	ON			80
ON	off	off	off	ON	off	ON		81	
off	ON	off	off	ON	off	ON		82	
ON	ON	off	off	ON	off	ON		83	
off	off	ON	off	ON	off	ON		84	
ON	off	ON	off	ON	off	ON		85	
off	ON	ON	off	ON	off	ON		86	
ON	ON	ON	off	ON	off	ON		87	
off	off	off	ON	ON	off	ON		88	
ON	off	off	ON	ON	off	ON		89	
off	ON	off	ON	ON	off	ON	GREEN	90	
ON	ON	off	ON	ON	off	ON	Shading from GREEN to CYAN	91	
off	off	ON	ON	ON	off	ON		92	
ON	off	ON	ON	ON	off	ON		93	
off	ON	ON	ON	ON	off	ON		94	
ON	ON	ON	ON	ON	off	ON		95	
off	off	off	off	off	ON	ON		96	
ON	off	off	off	off	ON	ON		97	
off	ON	off	off	off	ON	ON		98	
ON	ON	off	off	off	ON	ON		99	
off	off	ON	off	off	ON	ON		100	
ON	off	ON	off	off	ON	ON		101	
off	ON	ON	off	off	ON	ON		102	
ON	ON	ON	off	off	ON	ON		103	
off	off	off	ON	off	ON	ON		104	
ON	off	off	ON	off	ON	ON		105	
off	ON	off	ON	off	ON	ON		106	
ON	ON	off	ON	off	ON	ON		107	
off	off	ON	ON	off	ON	ON	CYAN	108	
ON	off	ON	ON	off	ON	ON	Shading from CYAN to BLUE	109	
off	ON	ON	ON	off	ON	ON		110	
ON	ON	ON	ON	off	ON	ON		111	
off	off	off	off	ON	ON	ON		112	
ON	off	off	off	ON	ON	ON		113	
off	ON	off	off	ON	ON	ON		114	
ON	ON	off	off	ON	ON	ON		115	
off	off	ON	off	ON	ON	ON		116	
ON	off	ON	off	ON	ON	ON		117	
off	ON	ON	off	ON	ON	ON		118	
ON	ON	ON	off	ON	ON	ON		119	
off	off	off	ON	ON	ON	ON		120	
ON	off	off	ON	ON	ON	ON		121	
off	ON	off	ON	ON	ON	ON		122	
ON	ON	off	ON	ON	ON	ON		123	
off	off	ON	ON	ON	ON	ON		124	
ON	off	ON	ON	ON	ON	ON		125	
off	ON	ON	ON	ON	ON	ON	126		
ON	ON	ON	ON	ON	ON	ON	BLUE	127	

## Lamp Replacement

- Disconnect the projector from the main power supply.
- Unscrew the 4 screws that hold the protection of the lamp holder.

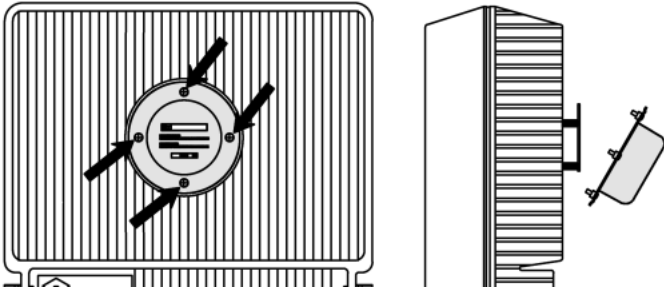

- Unscrew the 3 screws and remove the lamp holder

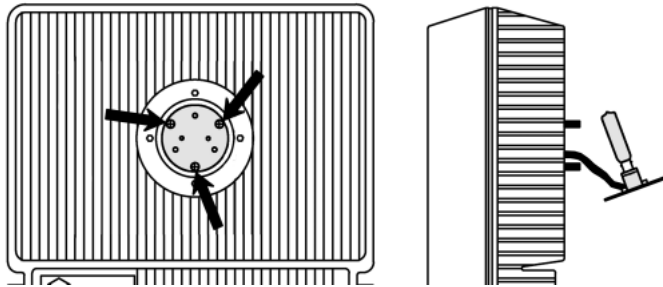

- Remove the lamp, taking care to wear proper protective gloves.
- Insert a new lamp.
- Re-insert the lamp holder.
- Fix well the 3 screws that hold the lamp holder.
- Re-insert the protection of the lamp holder.
- Fix well the 4 screws that hold the lamp holder.

Declared lamp life is 2000 hours.

We suggest to change the lamp before expiring time.

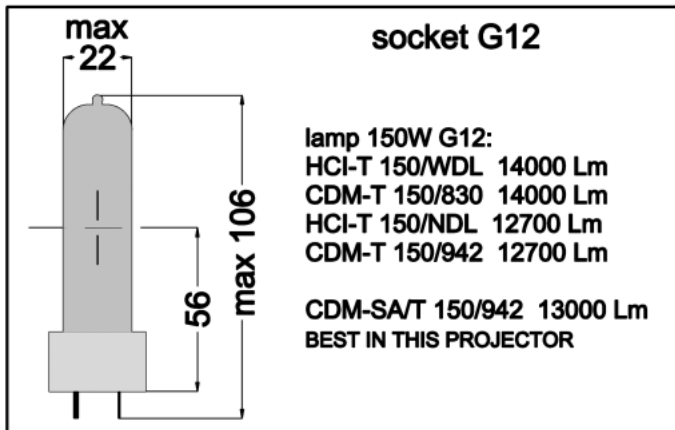

**DISCHARGE LAMPS CONTAIN SUBSTANCES THAT CAN POLLUTE THE AMBIENCE.  
 DISPOSE OF USING THE APPROPRIATE REFUGES (TOXIC).**

## **Spare parts**

When ordering spare parts for the projector remember to mention the model and serial number which can be found on the plate at the rear of the projector.

Call your area dealer or feel free to contact the manufacturer for any additional assistance.

### **SPARE PART LIST**

<b>CODE</b>	<b>DESCRIPTION</b>
<b>LP107</b>	<b>lamp CDM socket G12 4200°K</b>
PL28	G12 socket
PAR46	Aluminium reflector, hole 22mm
TR57	Transformer 230/14V 10VA
AL31	Ballast VAG 50/60Hz 1.8A
OB21	Capacitor 20microF
ACC14	Ignitor for lamp 150W
17HD-24-AT	Stepper motor, high temperature
2618142	Decorator bracket (specify the colour)
5108141	Temperate frontal glass, 263x306x5mm
OD150Z01	Lamp holder with silicone ring, screws and silicone small rings

The improper use of this projector, cancel the guarantee and our responsibility. All the information have been written and driven with extreme care; however, we do not engage us any responsibility for contingent errors or omissions. We reserve the right to modify and/ or improve our product as we retain necessary, without subsequent warning or notice. It is forbidden any complete or partial reproduction of this handbook, if not expressly authorized.