



## LAMPO lighting designers

46042 Castel Goffredo - Mantova - Italy

Via Portogallo, 4

tel +39 0376 770869 fax +39 0376 780947

www.lamposrl.it

e-mail info@lamposrl sales@lamposrl

tech@lamposrl exp@lamposrl

**ITALIANO**

## DECORATOR 250W wheel



**Cambia colori IP66**

**MANUALE D' USO versione 1.0**

*Questo manuale è da considerarsi parte integrante del proiettore.*

**PRIMA DI CONNETTERE E METTERE IN FUNZIONE IL PROIETTORE, E' IMPORTANTE LEGGERE ATTENTAMENTE QUANTO RIPORTATO NEL SEGUENTE MANUALE.**

**L'INSTALLAZIONE, LA MANUTENZIONE E L'UTILIZZO DI QUESTO PROIETTORE DEVONO ESSERE ESEGUITE SOLO DA PERSONALE QUALIFICATO, NEL RISPETTO DI TUTTE LE NORME DI SICUREZZA.**

**PRIMA DI EFFETTUARE IL COLLEGAMENTO ALLA RETE ELETTRICA, ASSICURATEVI CHE I VALORI DI FREQUENZA E DI TENSIONE SIANO CONFORMI A QUANTO INDICATO SUL PROIETTORE.**

**PER QUALUNQUE DUBBIO CONTATTATE IL VOSTRO RIVENDITORE OPPURE INVIATE UNA E-MAIL A:**

**tech@lamposrl.it**

**IP66**

SOLIDI: Totalmente protetto contro la polvere  
LIQUIDI: Protetto da ondate e potenti getti d'acqua



Istallabile direttamente su superfici normalmente infiammabili



Distanza minima dall'oggetto da illuminare (metri)

**ta 30 °C**

Temperatura ambiente massima (per interni con normale circolazione d'aria)



Connettere ad una rete elettrica provvista di un efficiente sistema di messa a terra ( EN60598-1 – Apparecchio in classe I )

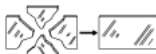

Sostituire gli schermi, filtri dicroici o lenti, rotti o deformati



4.5 KV

Circuito di accensione della lampada ad alta tensione

## **Indice**

<b>Dimensioni e peso</b> .....	<b>pag. 2</b>
<b>Dati tecnici</b> .....	<b>pag. 2</b>
<b>Imballaggio</b> .....	<b>pag. 2</b>
<b>Condizioni di funzionamento</b> .....	<b>pag. 3</b>
<b>Alimentazione elettrica</b> .....	<b>pag. 3</b>
<b>Esempi di connessione</b> .....	<b>pag. 4</b>
<b>Cavo di segnale DMX</b> .....	<b>pag. 4</b>
<b>Interfaccia utente</b> .....	<b>pag. 6</b>
<b>Specifiche DMX512</b> .....	<b>pag. 6</b>
<b>Impostare l'indirizzo DMX</b> .....	<b>pag. 6</b>
<b>Funzionamento automatico (stand alone)</b> .....	<b>pag. 11</b>
<b>Cambio lampada</b> .....	<b>pag. 13</b>
<b>Parti di ricambio</b> .....	<b>pag. 14</b>

## Dimensioni e pesi

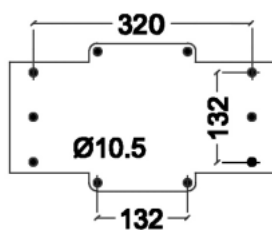
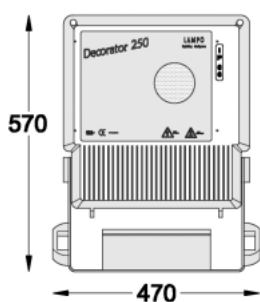

Peso: 16.5 Kg

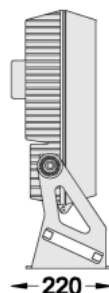

## Dati tecnici

- Cambiacolori a fascio stretto
- Lampada MSD 250W (attacco Gy9.5)
- Alimentatore magnetico, condensatore di rifasamento (1.8A @ 230VAC con lampada accesa)
- 5 filtri dicroici più il bianco, con il diffusore aggiuntivo (cod. AP44) si ottengono 11 combinazioni di colore
- Grado di protezione IP66 (non per immersione!)

### DECORATO 250 wheel

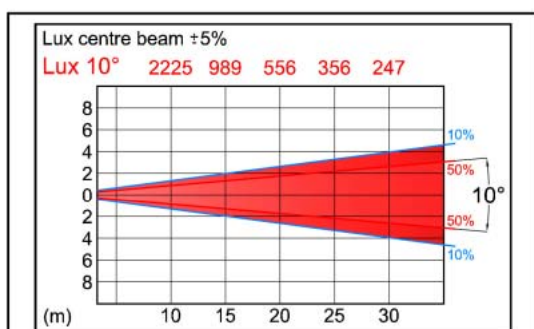

DECORATOR with optional diffuser (AP44)

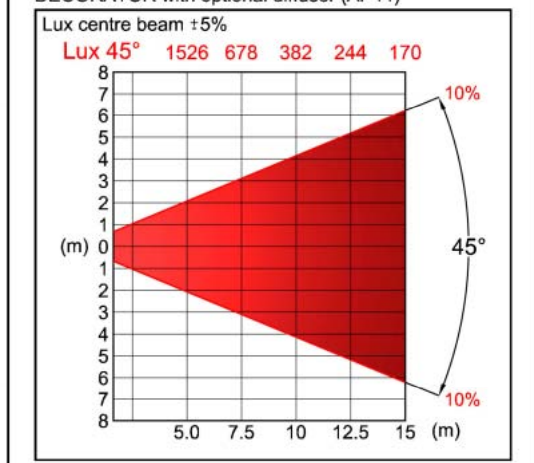

Lamp test: MSD 250W/2

Beam angle from 50% to 50%: 10°

Beam angle from 10% to 10%: 15°

Diameter to 50%: 0.175 x distance

Beam angle from 10% to 10%: 45° (with AP44)

Diameter to 10%: 0.83 x distance (with AP44)

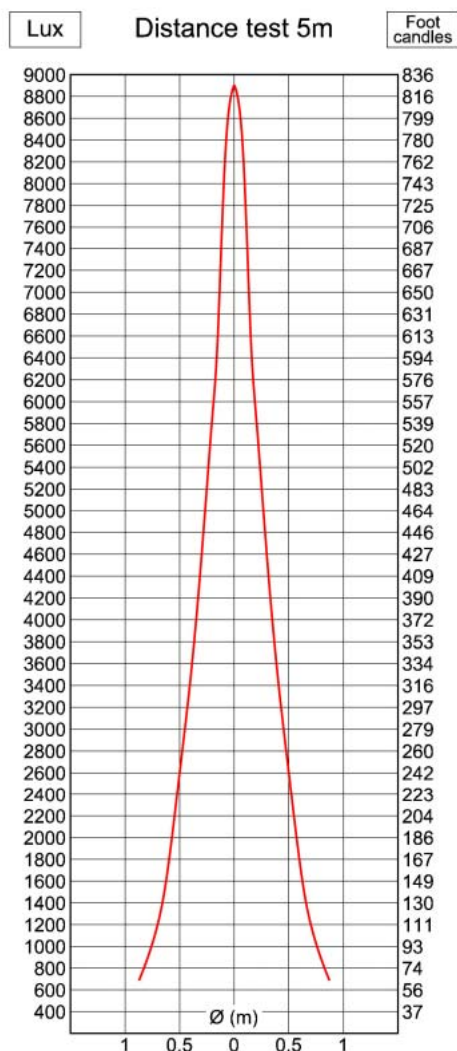

I dati sono indicativi, sono molto influenzabili dal tipo di lampada utilizzata e dalla marca.

## Imballo

Il proiettore, nel suo imballo originale, sigillato dal costruttore, può stare in zone umide con temperature fra -10°C e +50°C. Fare attenzione a non danneggiare il proiettore mentre viene tolto l'imballo.

## Condizioni di funzionamento

Il proiettore è stato studiato per funzionare in ambienti esterni, con una temperatura in aria, compresa fra 0° e 35°C con un livello di umidità compresa fra 30 e 90%.

Una volta scelto il luogo di installazione, verificare che il proiettore non sia esposto a temperature troppo elevate e in ogni caso non scegliere ambienti piccoli e non areati.

## Alimentazione elettrica

Prima di effettuare qualsiasi operazione, togliere tensione all'impianto elettrico.

Per connettere l'apparecchio, seguire la tabella e i disegni riportanti i colori dei conduttori e la loro posizione.

PIN	SYMBOL	EC	US	UK
phase	L	brown	yellow/c	red
neutral	N	blue	silver	black
ground		yellow/green	green	green

Non alimentare il proiettore da circuiti dimmer.

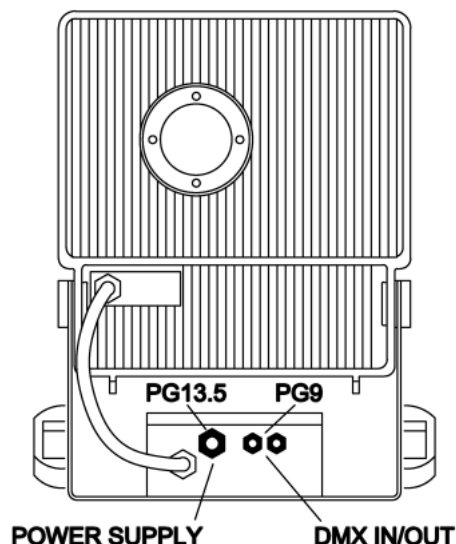
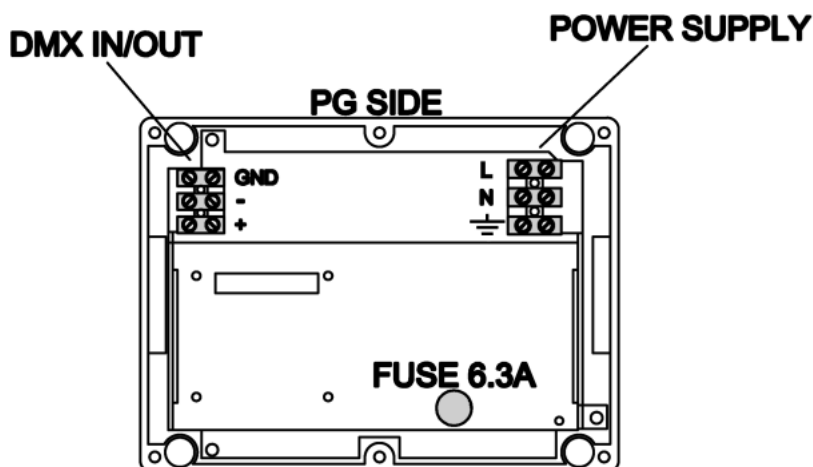

Se siete in dubbio, consultate un elettricista qualificato.

Il cavo di ingresso deve avere caratteristiche compatibili con il passacavo posto sul proiettore (PG13.5) deve quindi avere diametro esterno compreso fra 6 e 12mm.

Il proiettore può essere alimentato con tensione compresa fra 210Vac e 240Vac (sul corpo del proiettore è specificata la frequenza, 50 o 60 Hz). Sovra-tensioni provocano danneggiamenti ai componenti elettrici o elettronici, in oltre riducono la vita della lampada. Verificare il sistema elettrico prima di una installazione.

Quando si accende il proiettore, la corrente assorbita durante l'accensione è sensibilmente più alta di quella nominale. Dopo un minuto, prima che la lampada arrivi a regime, la corrente si abbassa a quella nominale, 1.8A a 230V.

Il proiettore è completamente a massa, è necessario collegarlo all'impianto di messa a terra.

Protegete il sistema elettrico con interruttori differenziali ad alta sensibilità, esempio 30mA.

All'interno del proiettore c'è un fusibile, se c'è un guasto elettrico, interrompe l'alimentazione all'ingresso. Risolto il guasto sostituire il fusibile con uno avente le stesse caratteristiche.

Attenzione, l'accenditore che è all'interno ha una tensione di uscita molto alta, può arrivare a 4.5KV.

## Esempi di collegamento

**Esempio 1:** Il segnale DMX è generato da un controller DMX, il cavo di segnale entra ed esce dai proiettori fino all'ultimo. I proiettori eseguono le stesse scene se il loro indirizzo DMX è uguale (in fabbrica viene impostato 1) oppure sono comandati singolarmente se hanno gli indirizzi DMX diversi fra loro (ogni proiettore occupa 1 solo canale DMX):

**Proiettore 1: DMX address 1    Proiettore 2: DMX address 2    Proiettore 3: DMX address 3**

### EXAMPLE 1

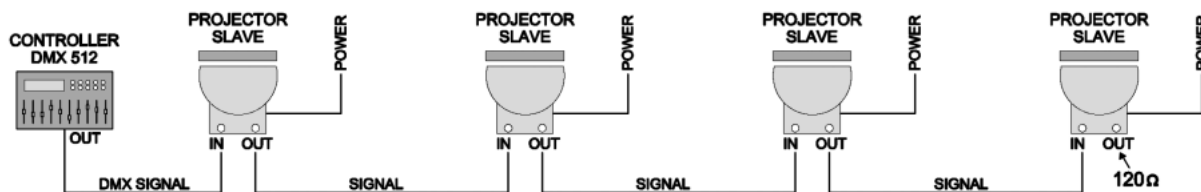

### EXAMPLE 2

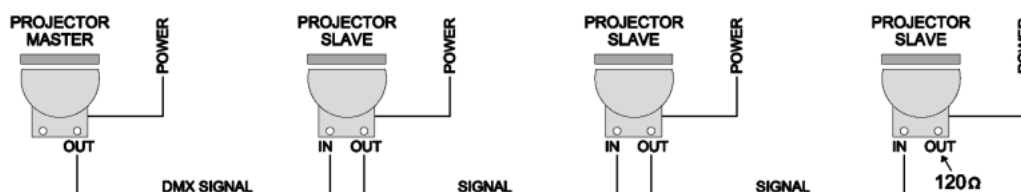

**Esempio 2:** Il segnale DMX è generato da un proiettore che funziona in modo automatico (proiettore detto MASTER). Il proiettore MASTER esegue delle scene in modo autonomo e comanda gli altri proiettori SLAVE della stessa tipologia.

Nei due esempi l'alimentazione elettrica (POWER) può provenire da sorgenti diverse, se un proiettore viene acceso successivamente, riceve il segnale DMX e si mette a funzionare come gli altri proiettori.

Se non viene acceso il DMX controller oppure il proiettore master, i proiettori generano luce bianca (no dimmer/black-out).

## Cavo di segnale DMX512

Utilizzare solo cavi schermati con conduttori twistati (attorcigliati) seguendo le specifiche EIA485 (RS485), con bassa capacità e impedenza compresa fra 82 e 120 ohm.

I normali cavi per l'audio non garantiscono una buona efficienza, sono quindi sconsigliati.

Si consiglia di seguire gli esempi nelle tabelle per avere un riferimento sulla tipologia di cavi da utilizzare

### Cavi con una coppia di conduttori

Marca	Cod.	AWG	Impedenza ohm
BELDEN	1162A	20	100
BELDEN	8227	20	100
BELDEN	89207	20	100
ALPHA	9109	20	100
ALPHA	9817	20	100
ALPHA	9818	20	100

### Cavi con 2 coppie di conduttori

Marca	Cod.	AWG	Impedenza ohm
BELDEN	8102	24	100
BELDEN	8162	24	100
BELDEN	89696	22	100
PROPLEX	PC224P	22	110
PROPLEX	PC224T	22	110

La sezione dei conduttori consigliata è 26 AWG o superiore.

Il diametro esterno del cavo deve essere compatibile con i passacavi PG9 del proiettore (diametro esterno fra 4 e 7mm).

E' consigliabile:

- Non inserire più di 32 proiettori sulla stessa linea Dmx
- Non superare la lunghezza massima di 150m di cavo (con cavi di bassa qualità)
- Non superare la lunghezza massima di 300m di cavo (con cavi di buona qualità)

Generalmente dalle centraline DMX (controller) c'è una sola uscita di segnale, se vi sono più i 32 proiettori è necessario installare nelle immediate vicinanze del controller uno SPLITTER di segnale, che duplica il segnale su due o più linee.

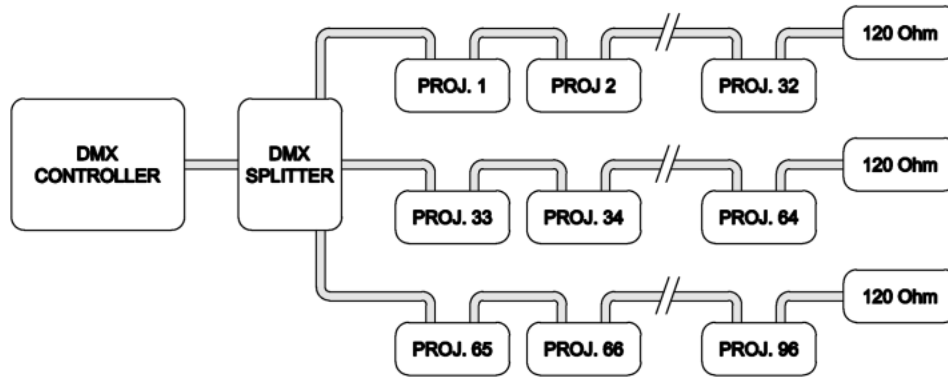

Se la lunghezza del cavo di segnale è troppo elevata bisogna installare un AMPLIFICATORE sulla linea DMX (almeno ogni 300m se il cavo è di buona qualità) in modo che ripeta il segnale per i proiettori successivi.

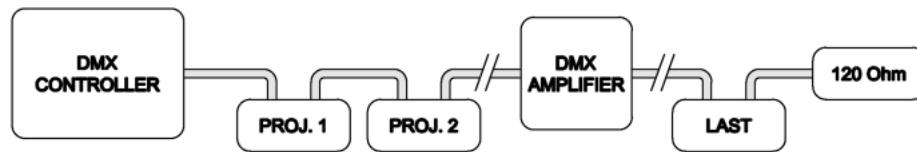

E' consigliabile terminare il circuito di segnale, all'interno dell'ultimo proiettore della catena o di ogni catena, con una resistenza (valore fra 82 e 120ohm) inserita fra il terminale positivo e negativo (+ e -).

#### DMX CONTROLLER OUT

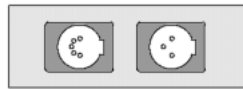

3pin or 5pin XLR panel connectors

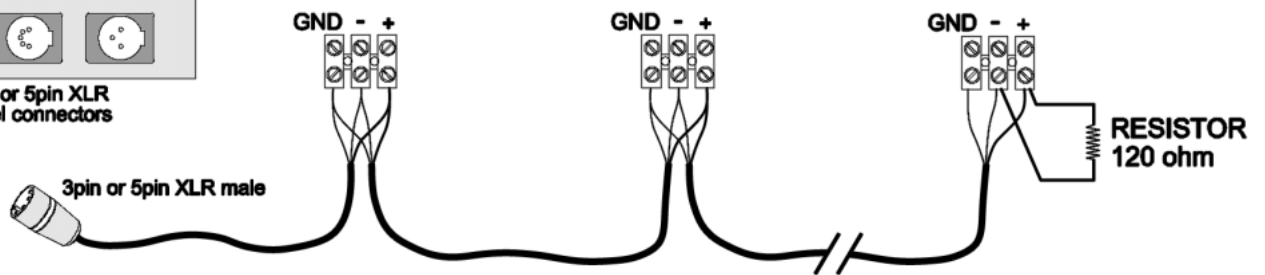

La connessione al controller DMX va effettuata, nella maggior parte dei casi, tramite connettori XLR maschio a 3 o a 5 poli.

Sul PIN 1 del connettore XLR deve essere saldato lo schermo del cavo di segnale, sul PIN 2 deve essere saldato il negativo (per esempio, conduttore nero), sul PIN 3 deve essere saldato il positivo (per esempio, conduttore rosso o bianco).

Bisogna rispettare la colorazione e l'ordine di collegamento anche sui morsetti all'interno dei proiettori, con sequenza diversa i proiettori non rispondono al segnale DMX.

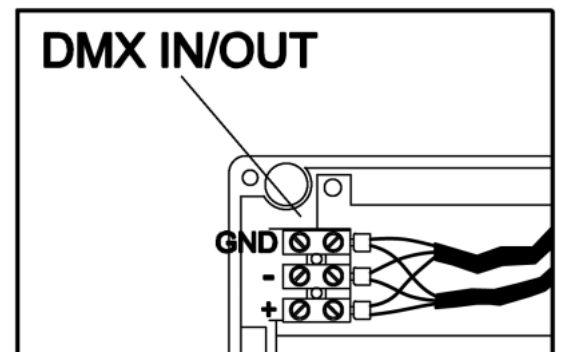
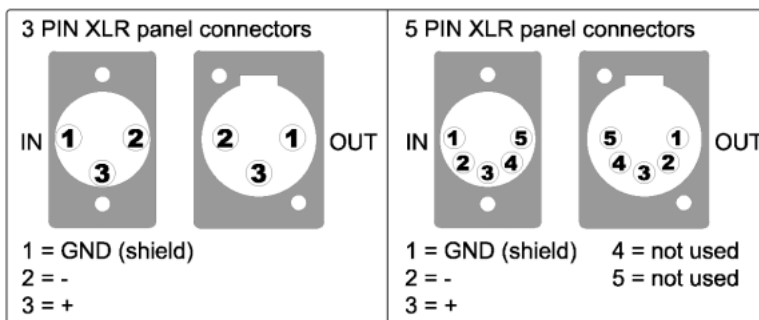

La connessione del segnale DMX all'interno del proiettore va eseguita collegando il segnale di entrata e il segnale di uscita direttamente nella morsetteria predisposta, facendo passare i cavi attraverso i pressatavi PG9.

## Interfaccia utente

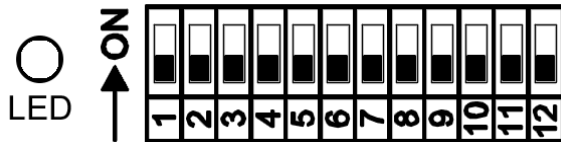

Il LED acceso indica la presenza del segnale DMX.

Il LED lampeggiante indica la mancanza del segnale DMX.

Per modificare l'indirizzo DMX e le impostazioni, bisogna spostare su ON o OFF i micro interruttori (chiamati dip-switch) seguendo le tabelle e i disegni riportati nei vari capitoli.

## Specifiche DMX512 del proiettore

Il proiettore usa un solo canale DMX, con valori da 0 a 255. ( 0 = bianco )

Fra 0 e 255 ci sono 11 posizioni del disco colori, corrispondenti agli 11 colori e bi-colori del disco colori.

Impostando su ON il dip-switch 11 è possibile far ruotare in modo libero il disco colori, senza indici.

## Impostare l'indirizzo DMX

Per poter comandare il proiettore con segnale DMX, è necessario assegnare al proiettore un indirizzo DMX (DMX address).

L'indirizzo DMX è il primo canale di comando del proiettore. In questo caso è l'unico canale di comando.

L'indirizzo DMX impostato in fabbrica è 1. Solamente il dip-switch 1 è in posizione ON.

Ad ogni dip-switch è associato un valore numerico, la somma dei valori decimali stabilisce il canale DMX di comando.

DIP-SWITCH	Valore DECIMALE
Dip 1	DMX add. (1)
Dip 2	DMX add. (2)
Dip 3	DMX add. (4)
Dip 4	DMX add. (8)
Dip 5	DMX add. (16)
Dip 6	DMX add. (32)
Dip 7	DMX add. (64)
Dip 8	DMX add. (128)
Dip 9	DMX add. (256)
Dip 10	Non usato
Dip 11	OFF=11 posizioni disco colori ON=posizioni libere disco colori
Dip 12	<b>OFF</b>



Esempio su come funzionano i dip-switches: per impostare l'indirizzo DMX (DMX address) **39**, bisogna mettere su ON i dip-switches corrispondenti ai valori decimali 32, 4, 2 e 1 in quanto  $32+4+2+1=39$ .

Per comandare il proiettore con segnale DMX (da DMX controller o da un proiettore che funziona in automatico) il dip-switch 12 deve essere in posizione di OFF (DMX / SLAVE).

Di seguito sono riportate le tabelle con le impostazioni dei dip-switches per ogni indirizzo DMX.



DMX	Dip1	Dip2	Dip3	Dip4	Dip5	Dip6	Dip7	Dip8	Dip9
	off	off	off	off	off	off	off	off	off
1	ON	off	off	off	off	off	off	off	off
2	off	ON	off	off	off	off	off	off	off
3	ON	ON	off	off	off	off	off	off	off
4	off	off	ON	off	off	off	off	off	off
5	ON	off	ON	off	off	off	off	off	off
6	off	ON	ON	off	off	off	off	off	off
7	ON	ON	ON	off	off	off	off	off	off
8	off	off	off	ON	off	off	off	off	off
9	ON	off	off	ON	off	off	off	off	off
10	off	ON	off	ON	off	off	off	off	off
11	ON	ON	off	ON	off	off	off	off	off
12	off	off	ON	ON	off	off	off	off	off
13	ON	off	ON	ON	off	off	off	off	off
14	off	ON	ON	ON	off	off	off	off	off
15	ON	ON	ON	ON	off	off	off	off	off
16	off	off	off	off	ON	off	off	off	off
17	ON	off	off	off	ON	off	off	off	off
18	off	ON	off	off	ON	off	off	off	off
19	ON	ON	off	off	ON	off	off	off	off
20	off	off	ON	off	ON	off	off	off	off
21	ON	off	ON	off	ON	off	off	off	off
22	off	ON	ON	off	ON	off	off	off	off
23	ON	ON	ON	off	ON	off	off	off	off
24	off	off	off	ON	ON	off	off	off	off
25	ON	off	off	ON	ON	off	off	off	off
26	off	ON	off	ON	ON	off	off	off	off
27	ON	ON	off	ON	ON	off	off	off	off
28	off	off	ON	ON	ON	off	off	off	off
29	ON	off	ON	ON	ON	off	off	off	off
30	off	ON	ON	ON	ON	off	off	off	off
31	ON	ON	ON	ON	ON	off	off	off	off
32	off	off	off	off	off	ON	off	off	off
33	ON	off	off	off	off	ON	off	off	off
34	off	ON	off	off	off	ON	off	off	off
35	ON	ON	off	off	off	ON	off	off	off
36	off	off	ON	off	off	ON	off	off	off
37	ON	off	ON	off	off	ON	off	off	off
38	off	ON	ON	off	off	ON	off	off	off
39	ON	ON	ON	off	off	ON	off	off	off
40	off	off	off	ON	off	ON	off	off	off
41	ON	off	off	ON	off	ON	off	off	off
42	off	ON	off	ON	off	ON	off	off	off
43	ON	ON	off	ON	off	ON	off	off	off
44	off	off	ON	ON	off	ON	off	off	off
45	ON	off	ON	ON	off	ON	off	off	off
46	off	ON	ON	ON	off	ON	off	off	off
47	ON	ON	ON	ON	off	ON	off	off	off
48	off	off	off	off	ON	ON	off	off	off
49	ON	off	off	off	ON	ON	off	off	off
50	off	ON	off	off	ON	ON	off	off	off
51	ON	ON	off	off	ON	ON	off	off	off
52	off	off	ON	off	ON	ON	off	off	off
53	ON	off	ON	off	ON	ON	off	off	off
54	off	ON	ON	off	ON	ON	off	off	off
55	ON	ON	ON	off	ON	ON	off	off	off
56	off	off	off	ON	ON	ON	off	off	off
57	ON	off	off	ON	ON	ON	off	off	off
58	off	ON	off	ON	ON	ON	off	off	off
59	ON	ON	off	ON	ON	ON	off	off	off
60	off	off	ON	ON	ON	ON	off	off	off
61	ON	off	ON	ON	ON	ON	off	off	off
62	off	ON	ON	ON	ON	ON	off	off	off
63	ON	ON	ON	ON	ON	ON	off	off	off

DMX	Dip1	Dip2	Dip3	Dip4	Dip5	Dip6	Dip7	Dip8	Dip9
64	off	off	off	off	off	off	ON	off	off
65	ON	off	off	off	off	off	ON	off	off
66	off	ON	off	off	off	off	ON	off	off
67	ON	ON	off	off	off	off	ON	off	off
68	off	off	ON	off	off	off	ON	off	off
69	ON	off	ON	off	off	off	ON	off	off
70	off	ON	ON	off	off	off	ON	off	off
71	ON	ON	ON	off	off	off	ON	off	off
72	off	off	off	ON	off	off	ON	off	off
73	ON	off	off	ON	off	off	ON	off	off
74	off	ON	off	ON	off	off	ON	off	off
75	ON	ON	off	ON	off	off	ON	off	off
76	off	off	ON	ON	off	off	ON	off	off
77	ON	off	ON	ON	off	off	ON	off	off
78	off	ON	ON	ON	off	off	ON	off	off
79	ON	ON	ON	ON	off	off	ON	off	off
80	off	off	off	off	ON	off	ON	off	off
81	ON	off	off	off	ON	off	ON	off	off
82	off	ON	off	off	ON	off	ON	off	off
83	ON	ON	off	off	ON	off	ON	off	off
84	off	off	ON	off	ON	off	ON	off	off
85	ON	off	ON	off	ON	off	ON	off	off
86	off	ON	ON	off	ON	off	ON	off	off
87	ON	ON	ON	off	ON	off	ON	off	off
88	off	off	off	ON	ON	off	ON	off	off
89	ON	off	off	ON	ON	off	ON	off	off
90	off	ON	off	ON	ON	off	ON	off	off
91	ON	ON	off	ON	ON	off	ON	off	off
92	off	off	ON	ON	ON	off	ON	off	off
93	ON	off	ON	ON	ON	off	ON	off	off
94	off	ON	ON	ON	ON	off	ON	off	off
95	ON	ON	ON	ON	ON	off	ON	off	off
96	off	off	off	off	off	ON	ON	off	off
97	ON	off	off	off	off	ON	ON	off	off
98	off	ON	off	off	off	ON	ON	off	off
99	ON	ON	off	off	off	ON	ON	off	off
100	off	off	ON	off	off	ON	ON	off	off
101	ON	off	ON	off	off	ON	ON	off	off
102	off	ON	ON	off	off	ON	ON	off	off
103	ON	ON	ON	off	off	ON	ON	off	off
104	off	off	off	ON	off	ON	ON	off	off
105	ON	off	off	ON	off	ON	ON	off	off
106	off	ON	off	ON	off	ON	ON	off	off
107	ON	ON	off	ON	off	ON	ON	off	off
108	off	off	ON	ON	off	ON	ON	off	off
109	ON	off	ON	ON	off	ON	ON	off	off
110	off	ON	ON	ON	off	ON	ON	off	off
111	ON	ON	ON	ON	off	ON	ON	off	off
112	off	off	off	off	ON	ON	ON	off	off
113	ON	off	off	off	ON	ON	ON	off	off
114	off	ON	off	off	ON	ON	ON	off	off
115	ON	ON	off	off	ON	ON	ON	off	off
116	off	off	ON	off	ON	ON	ON	off	off
117	ON	off	ON	off	ON	ON	ON	off	off
118	off	ON	ON	off	ON	ON	ON	off	off
119	ON	ON	ON	off	ON	ON	ON	off	off
120	off	off	off	ON	ON	ON	ON	off	off
121	ON	off	off	ON	ON	ON	ON	off	off
122	off	ON	off	ON	ON	ON	ON	off	off
123	ON	ON	off	ON	ON	ON	ON	off	off
124	off	off	ON	ON	ON	ON	ON	off	off
125	ON	off	ON	ON	ON	ON	ON	off	off
126	off	ON	ON	ON	ON	ON	ON	off	off
127	ON	ON	ON	ON	ON	ON	ON	off	off

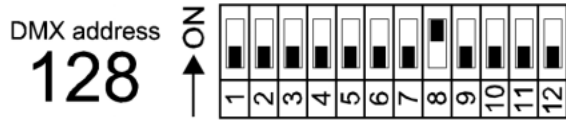

DMX	Dip1	Dip2	Dip3	Dip4	Dip5	Dip6	Dip7	Dip8	Dip9
128	off	off	off	off	off	off	off	ON	off
129	ON	off	off	off	off	off	off	ON	off
130	off	ON	off	off	off	off	off	ON	off
131	ON	ON	off	off	off	off	off	ON	off
132	off	off	ON	off	off	off	off	ON	off
133	ON	off	ON	off	off	off	off	ON	off
134	off	ON	ON	off	off	off	off	ON	off
135	ON	ON	ON	off	off	off	off	ON	off
136	off	off	off	ON	off	off	off	ON	off
137	ON	off	off	ON	off	off	off	ON	off
138	off	ON	off	ON	off	off	off	ON	off
139	ON	ON	off	ON	off	off	off	ON	off
140	off	off	ON	ON	off	off	off	ON	off
141	ON	off	ON	ON	off	off	off	ON	off
142	off	ON	ON	ON	off	off	off	ON	off
143	ON	ON	ON	ON	off	off	off	ON	off
144	off	off	off	off	ON	off	off	ON	off
145	ON	off	off	off	ON	off	off	ON	off
146	off	ON	off	off	ON	off	off	ON	off
147	ON	ON	off	off	ON	off	off	ON	off
148	off	off	ON	off	ON	off	off	ON	off
149	ON	off	ON	off	ON	off	off	ON	off
150	off	ON	ON	off	ON	off	off	ON	off
151	ON	ON	ON	off	ON	off	off	ON	off
152	off	off	off	ON	ON	off	off	ON	off
153	ON	off	off	ON	ON	off	off	ON	off
154	off	ON	off	ON	ON	off	off	ON	off
155	ON	ON	off	ON	ON	off	off	ON	off
156	off	off	ON	ON	ON	off	off	ON	off
157	ON	off	ON	ON	ON	off	off	ON	off
158	off	ON	ON	ON	ON	off	off	ON	off
159	ON	ON	ON	ON	ON	off	off	ON	off
160	off	off	off	off	off	ON	off	ON	off
161	ON	off	off	off	off	ON	off	ON	off
162	off	ON	off	off	off	ON	off	ON	off
163	ON	ON	off	off	off	ON	off	ON	off
164	off	off	ON	off	off	ON	off	ON	off
165	ON	off	ON	off	off	ON	off	ON	off
166	off	ON	ON	off	off	ON	off	ON	off
167	ON	ON	ON	off	off	ON	off	ON	off
168	off	off	off	ON	off	ON	off	ON	off
169	ON	off	off	ON	off	ON	off	ON	off
170	off	ON	off	ON	off	ON	off	ON	off
171	ON	ON	off	ON	off	ON	off	ON	off
172	off	off	ON	ON	off	ON	off	ON	off
173	ON	off	ON	ON	off	ON	off	ON	off
174	off	ON	ON	ON	off	ON	off	ON	off
175	ON	ON	ON	ON	off	ON	off	ON	off
176	off	off	off	off	ON	ON	off	ON	off
177	ON	off	off	off	ON	ON	off	ON	off
178	off	ON	off	off	ON	ON	off	ON	off
179	ON	ON	off	off	ON	ON	off	ON	off
180	off	off	ON	off	ON	ON	off	ON	off
181	ON	off	ON	off	ON	ON	off	ON	off
182	off	ON	ON	off	ON	ON	off	ON	off
183	ON	ON	ON	off	ON	ON	off	ON	off
184	off	off	off	ON	ON	ON	off	ON	off
185	ON	off	off	ON	ON	ON	off	ON	off
186	off	ON	off	ON	ON	ON	off	ON	off
187	ON	ON	off	ON	ON	ON	off	ON	off
188	off	off	ON	ON	ON	ON	off	ON	off
189	ON	off	ON	ON	ON	ON	off	ON	off
190	off	ON	ON	ON	ON	ON	off	ON	off
191	ON	ON	ON	ON	ON	ON	off	ON	off

DMX	Dip1	Dip2	Dip3	Dip4	Dip5	Dip6	Dip7	Dip8	Dip9
192	off	off	off	off	off	off	ON	ON	off
193	ON	off	off	off	off	off	ON	ON	off
194	off	ON	off	off	off	off	ON	ON	off
195	ON	ON	off	off	off	off	ON	ON	off
196	off	off	ON	off	off	off	ON	ON	off
197	ON	off	ON	off	off	off	ON	ON	off
198	off	ON	ON	off	off	off	ON	ON	off
199	ON	ON	ON	off	off	off	ON	ON	off
200	off	off	off	ON	off	off	ON	ON	off
201	ON	off	off	ON	off	off	ON	ON	off
202	off	ON	off	ON	off	off	ON	ON	off
203	ON	ON	off	ON	off	off	ON	ON	off
204	off	off	ON	ON	off	off	ON	ON	off
205	ON	off	ON	ON	off	off	ON	ON	off
206	off	ON	ON	ON	off	off	ON	ON	off
207	ON	ON	ON	ON	off	off	ON	ON	off
208	off	off	off	off	ON	off	ON	ON	off
209	ON	off	off	off	ON	off	ON	ON	off
210	off	ON	off	off	ON	off	ON	ON	off
211	ON	ON	off	off	ON	off	ON	ON	off
212	off	off	ON	off	ON	off	ON	ON	off
213	ON	off	ON	off	ON	off	ON	ON	off
214	off	ON	ON	off	ON	off	ON	ON	off
215	ON	ON	ON	off	ON	off	ON	ON	off
216	off	off	off	ON	ON	off	ON	ON	off
217	ON	off	off	ON	ON	off	ON	ON	off
218	off	ON	off	ON	ON	off	ON	ON	off
219	ON	ON	off	ON	ON	off	ON	ON	off
220	off	off	ON	ON	ON	off	ON	ON	off
221	ON	off	ON	ON	ON	off	ON	ON	off
222	off	ON	ON	ON	ON	off	ON	ON	off
223	ON	ON	ON	ON	ON	off	ON	ON	off
224	off	off	off	off	off	ON	ON	ON	off
225	ON	off	off	off	off	ON	ON	ON	off
226	off	ON	off	off	off	ON	ON	ON	off
227	ON	ON	off	off	off	ON	ON	ON	off
228	off	off	ON	off	off	ON	ON	ON	off
229	ON	off	ON	off	off	ON	ON	ON	off
230	off	ON	ON	off	off	ON	ON	ON	off
231	ON	ON	ON	off	off	ON	ON	ON	off
232	off	off	off	ON	off	ON	ON	ON	off
233	ON	off	off	ON	off	ON	ON	ON	off
234	off	ON	off	ON	off	ON	ON	ON	off
235	ON	ON	off	ON	off	ON	ON	ON	off
236	off	off	ON	ON	off	ON	ON	ON	off
237	ON	off	ON	ON	off	ON	ON	ON	off
238	off	ON	ON	ON	off	ON	ON	ON	off
239	ON	ON	ON	ON	off	ON	ON	ON	off
240	off	off	off	off	ON	ON	ON	ON	off
241	ON	off	off	off	ON	ON	ON	ON	off
242	off	ON	off	off	ON	ON	ON	ON	off
243	ON	ON	off	off	ON	ON	ON	ON	off
244	off	off	ON	off	ON	ON	ON	ON	off
245	ON	off	ON	off	ON	ON	ON	ON	off
246	off	ON	ON	off	ON	ON	ON	ON	off
247	ON	ON	ON	off	ON	ON	ON	ON	off
248	off	off	off	ON	ON	ON	ON	ON	off
249	ON	off	off	ON	ON	ON	ON	ON	off
250	off	ON	off	ON	ON	ON	ON	ON	off
251	ON	ON	off	ON	ON	ON	ON	ON	off
252	off	off	ON	ON	ON	ON	ON	ON	off
253	ON	off	ON	ON	ON	ON	ON	ON	off
254	off	ON	ON	ON	ON	ON	ON	ON	off
255	ON	ON	ON	ON	ON	ON	ON	ON	off



DMX	Dip1	Dip2	Dip3	Dip4	Dip5	Dip6	Dip7	Dip8	Dip9
256	off	off	off	off	off	off	off	off	ON
257	ON	off	off	off	off	off	off	off	ON
258	off	ON	off	off	off	off	off	off	ON
259	ON	ON	off	off	off	off	off	off	ON
260	off	off	ON	off	off	off	off	off	ON
261	ON	off	ON	off	off	off	off	off	ON
262	off	ON	ON	off	off	off	off	off	ON
263	ON	ON	ON	off	off	off	off	off	ON
264	off	off	off	ON	off	off	off	off	ON
265	ON	off	off	ON	off	off	off	off	ON
266	off	ON	off	ON	off	off	off	off	ON
267	ON	ON	off	ON	off	off	off	off	ON
268	off	off	ON	ON	off	off	off	off	ON
269	ON	off	ON	ON	off	off	off	off	ON
270	off	ON	ON	ON	off	off	off	off	ON
271	ON	ON	ON	ON	off	off	off	off	ON
272	off	off	off	off	ON	off	off	off	ON
273	ON	off	off	off	ON	off	off	off	ON
274	off	ON	off	off	ON	off	off	off	ON
275	ON	ON	off	off	ON	off	off	off	ON
276	off	off	ON	off	ON	off	off	off	ON
277	ON	off	ON	off	ON	off	off	off	ON
278	off	ON	ON	off	ON	off	off	off	ON
279	ON	ON	ON	off	ON	off	off	off	ON
280	off	off	off	ON	ON	off	off	off	ON
281	ON	off	off	ON	ON	off	off	off	ON
282	off	ON	off	ON	ON	off	off	off	ON
283	ON	ON	off	ON	ON	off	off	off	ON
284	off	off	ON	ON	ON	off	off	off	ON
285	ON	off	ON	ON	ON	off	off	off	ON
286	off	ON	ON	ON	ON	off	off	off	ON
287	ON	ON	ON	ON	ON	off	off	off	ON
288	off	off	off	off	off	ON	off	off	ON
289	ON	off	off	off	off	ON	off	off	ON
290	off	ON	off	off	off	ON	off	off	ON
291	ON	ON	off	off	off	ON	off	off	ON
292	off	off	ON	off	off	ON	off	off	ON
293	ON	off	ON	off	off	ON	off	off	ON
294	off	ON	ON	off	off	ON	off	off	ON
295	ON	ON	ON	off	off	ON	off	off	ON
296	off	off	off	ON	off	ON	off	off	ON
297	ON	off	off	ON	off	ON	off	off	ON
298	off	ON	off	ON	off	ON	off	off	ON
299	ON	ON	off	ON	off	ON	off	off	ON
300	off	off	ON	ON	off	ON	off	off	ON
301	ON	off	ON	ON	off	ON	off	off	ON
302	off	ON	ON	ON	off	ON	off	off	ON
303	ON	ON	ON	ON	off	ON	off	off	ON
304	off	off	off	off	ON	ON	off	off	ON
305	ON	off	off	off	ON	ON	off	off	ON
306	off	ON	off	off	ON	ON	off	off	ON
307	ON	ON	off	off	ON	ON	off	off	ON
308	off	off	ON	off	ON	ON	off	off	ON
309	ON	off	ON	off	ON	ON	off	off	ON
310	off	ON	ON	off	ON	ON	off	off	ON
311	ON	ON	ON	off	ON	ON	off	off	ON
312	off	off	off	ON	ON	ON	off	off	ON
313	ON	off	off	ON	ON	ON	off	off	ON
314	off	ON	off	ON	ON	ON	off	off	ON
315	ON	ON	off	ON	ON	ON	off	off	ON
316	off	off	ON	ON	ON	ON	off	off	ON
317	ON	off	ON	ON	ON	ON	off	off	ON
318	off	ON	ON	ON	ON	ON	off	off	ON
319	ON	ON	ON	ON	ON	ON	off	off	ON

DMX	Dip1	Dip2	Dip3	Dip4	Dip5	Dip6	Dip7	Dip8	Dip9
320	off	off	off	off	off	off	ON	off	ON
321	ON	off	off	off	off	off	ON	off	ON
322	off	ON	off	off	off	off	ON	off	ON
323	ON	ON	off	off	off	off	ON	off	ON
324	off	off	ON	off	off	off	ON	off	ON
325	ON	off	ON	off	off	off	ON	off	ON
326	off	ON	ON	off	off	off	ON	off	ON
327	ON	ON	ON	off	off	off	ON	off	ON
328	off	off	off	ON	off	off	ON	off	ON
329	ON	off	off	ON	off	off	ON	off	ON
330	off	ON	off	ON	off	off	ON	off	ON
331	ON	ON	off	ON	off	off	ON	off	ON
332	off	off	ON	ON	off	off	ON	off	ON
333	ON	off	ON	ON	off	off	ON	off	ON
334	off	ON	ON	ON	off	off	ON	off	ON
335	ON	ON	ON	ON	off	off	ON	off	ON
336	off	off	off	off	ON	off	ON	off	ON
337	ON	off	off	off	ON	off	ON	off	ON
338	off	ON	off	off	ON	off	ON	off	ON
339	ON	ON	off	off	ON	off	ON	off	ON
340	off	off	ON	off	ON	off	ON	off	ON
341	ON	off	ON	off	ON	off	ON	off	ON
342	off	ON	ON	off	ON	off	ON	off	ON
343	ON	ON	ON	off	ON	off	ON	off	ON
344	off	off	off	ON	ON	off	ON	off	ON
345	ON	off	off	ON	ON	off	ON	off	ON
346	off	ON	off	ON	ON	off	ON	off	ON
347	ON	ON	off	ON	ON	off	ON	off	ON
348	off	off	ON	ON	ON	off	ON	off	ON
349	ON	off	ON	ON	ON	off	ON	off	ON
350	off	ON	ON	ON	ON	off	ON	off	ON
351	ON	ON	ON	ON	ON	off	ON	off	ON
352	off	off	off	off	off	ON	ON	off	ON
353	ON	off	off	off	off	ON	ON	off	ON
354	off	ON	off	off	off	ON	ON	off	ON
355	ON	ON	off	off	off	ON	ON	off	ON
356	off	off	ON	off	off	ON	ON	off	ON
357	ON	off	ON	off	off	ON	ON	off	ON
358	off	ON	ON	off	off	ON	ON	off	ON
359	ON	ON	ON	off	off	ON	ON	off	ON
360	off	off	off	ON	off	ON	ON	off	ON
361	ON	off	off	ON	off	ON	ON	off	ON
362	off	ON	off	ON	off	ON	ON	off	ON
363	ON	ON	off	ON	off	ON	ON	off	ON
364	off	off	ON	ON	off	ON	ON	off	ON
365	ON	off	ON	ON	off	ON	ON	off	ON
366	off	ON	ON	ON	off	ON	ON	off	ON
367	ON	ON	ON	ON	off	ON	ON	off	ON
368	off	off	off	off	ON	ON	ON	off	ON
369	ON	off	off	off	ON	ON	ON	off	ON
370	off	ON	off	off	ON	ON	ON	off	ON
371	ON	ON	off	off	ON	ON	ON	off	ON
372	off	off	ON	off	ON	ON	ON	off	ON
373	ON	off	ON	off	ON	ON	ON	off	ON
374	off	ON	ON	off	ON	ON	ON	off	ON
375	ON	ON	ON	off	ON	ON	ON	off	ON
376	off	off	off	ON	ON	ON	ON	off	ON
377	ON	off	off	ON	ON	ON	ON	off	ON
378	off	ON	off	ON	ON	ON	ON	off	ON
379	ON	ON	off	ON	ON	ON	ON	off	ON
380	off	off	ON	ON	ON	ON	ON	off	ON
381	ON	off	ON	ON	ON	ON	ON	off	ON
382	off	ON	ON	ON	ON	ON	ON	off	ON
383	ON	ON	ON	ON	ON	ON	ON	off	ON

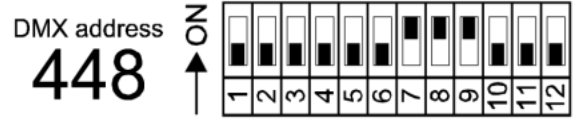
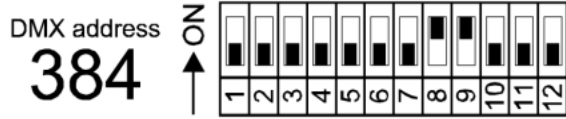

DMX	Dip1	Dip2	Dip3	Dip4	Dip5	Dip6	Dip7	Dip8	Dip9
384	off	off	off	off	off	off	off	ON	ON
385	ON	off	off	off	off	off	off	ON	ON
386	off	ON	off	off	off	off	off	ON	ON
387	ON	ON	off	off	off	off	off	ON	ON
388	off	off	ON	off	off	off	off	ON	ON
389	ON	off	ON	off	off	off	off	ON	ON
390	off	ON	ON	off	off	off	off	ON	ON
391	ON	ON	ON	off	off	off	off	ON	ON
392	off	off	off	ON	off	off	off	ON	ON
393	ON	off	off	ON	off	off	off	ON	ON
394	off	ON	off	ON	off	off	off	ON	ON
395	ON	ON	off	ON	off	off	off	ON	ON
396	off	off	ON	ON	off	off	off	ON	ON
397	ON	off	ON	ON	off	off	off	ON	ON
398	off	ON	ON	ON	off	off	off	ON	ON
399	ON	ON	ON	ON	off	off	off	ON	ON
400	off	off	off	off	ON	off	off	ON	ON
401	ON	off	off	off	ON	off	off	ON	ON
402	off	ON	off	off	ON	off	off	ON	ON
403	ON	ON	off	off	ON	off	off	ON	ON
404	off	off	ON	off	ON	off	off	ON	ON
405	ON	off	ON	off	ON	off	off	ON	ON
406	off	ON	ON	off	ON	off	off	ON	ON
407	ON	ON	ON	off	ON	off	off	ON	ON
408	off	off	off	ON	ON	off	off	ON	ON
409	ON	off	off	ON	ON	off	off	ON	ON
410	off	ON	off	ON	ON	off	off	ON	ON
411	ON	ON	off	ON	ON	off	off	ON	ON
412	off	off	ON	ON	ON	off	off	ON	ON
413	ON	off	ON	ON	ON	off	off	ON	ON
414	off	ON	ON	ON	ON	off	off	ON	ON
415	ON	ON	ON	ON	ON	off	off	ON	ON
416	off	off	off	off	off	ON	off	ON	ON
417	ON	off	off	off	off	ON	off	ON	ON
418	off	ON	off	off	off	ON	off	ON	ON
419	ON	ON	off	off	off	ON	off	ON	ON
420	off	off	ON	off	off	ON	off	ON	ON
421	ON	off	ON	off	off	ON	off	ON	ON
422	off	ON	ON	off	off	ON	off	ON	ON
423	ON	ON	ON	off	off	ON	off	ON	ON
424	off	off	off	ON	off	ON	off	ON	ON
425	ON	off	off	ON	off	ON	off	ON	ON
426	off	ON	off	ON	off	ON	off	ON	ON
427	ON	ON	off	ON	off	ON	off	ON	ON
428	off	off	ON	ON	off	ON	off	ON	ON
429	ON	off	ON	ON	off	ON	off	ON	ON
430	off	ON	ON	ON	off	ON	off	ON	ON
431	ON	ON	ON	ON	off	ON	off	ON	ON
432	off	off	off	off	ON	ON	off	ON	ON
433	ON	off	off	off	ON	ON	off	ON	ON
434	off	ON	off	off	ON	ON	off	ON	ON
435	ON	ON	off	off	ON	ON	off	ON	ON
436	off	off	ON	off	ON	ON	off	ON	ON
437	ON	off	ON	off	ON	ON	off	ON	ON
438	off	ON	ON	off	ON	ON	off	ON	ON
439	ON	ON	ON	off	ON	ON	off	ON	ON
440	off	off	off	ON	ON	ON	off	ON	ON
441	ON	off	off	ON	ON	ON	off	ON	ON
442	off	ON	off	ON	ON	ON	off	ON	ON
443	ON	ON	off	ON	ON	ON	off	ON	ON
444	off	off	ON	ON	ON	ON	off	ON	ON
445	ON	off	ON	ON	ON	ON	off	ON	ON
446	off	ON	ON	ON	ON	ON	off	ON	ON
447	ON	ON	ON	ON	ON	ON	off	ON	ON

DMX	Dip1	Dip2	Dip3	Dip4	Dip5	Dip6	Dip7	Dip8	Dip9
448	off	off	off	off	off	off	ON	ON	ON
449	ON	off	off	off	off	off	ON	ON	ON
450	off	ON	off	off	off	off	ON	ON	ON
451	ON	ON	off	off	off	off	ON	ON	ON
452	off	off	ON	off	off	off	ON	ON	ON
453	ON	off	ON	off	off	off	ON	ON	ON
454	off	ON	ON	off	off	off	ON	ON	ON
455	ON	ON	ON	off	off	off	ON	ON	ON
456	off	off	off	ON	off	off	ON	ON	ON
457	ON	off	off	ON	off	off	ON	ON	ON
458	off	ON	off	ON	off	off	ON	ON	ON
459	ON	ON	off	ON	off	off	ON	ON	ON
460	off	off	ON	ON	off	off	ON	ON	ON
461	ON	off	ON	ON	off	off	ON	ON	ON
462	off	ON	ON	ON	off	off	ON	ON	ON
463	ON	ON	ON	ON	off	off	ON	ON	ON
464	off	off	off	off	ON	off	ON	ON	ON
465	ON	off	off	off	ON	off	ON	ON	ON
466	off	ON	off	off	ON	off	ON	ON	ON
467	ON	ON	off	off	ON	off	ON	ON	ON
468	off	off	ON	off	ON	off	ON	ON	ON
469	ON	off	ON	off	ON	off	ON	ON	ON
470	off	ON	ON	off	ON	off	ON	ON	ON
471	ON	ON	ON	off	ON	off	ON	ON	ON
472	off	off	off	ON	ON	off	ON	ON	ON
473	ON	off	off	ON	ON	off	ON	ON	ON
474	off	ON	off	ON	ON	off	ON	ON	ON
475	ON	ON	off	ON	ON	off	ON	ON	ON
476	off	off	ON	ON	ON	off	ON	ON	ON
477	ON	off	ON	ON	ON	off	ON	ON	ON
478	off	ON	ON	ON	ON	off	ON	ON	ON
479	ON	ON	ON	ON	ON	off	ON	ON	ON
480	off	off	off	off	off	ON	ON	ON	ON
481	ON	off	off	off	off	ON	ON	ON	ON
482	off	ON	off	off	off	ON	ON	ON	ON
483	ON	ON	off	off	off	ON	ON	ON	ON
484	off	off	ON	off	off	ON	ON	ON	ON
485	ON	off	ON	off	off	ON	ON	ON	ON
486	off	ON	ON	off	off	ON	ON	ON	ON
487	ON	ON	ON	off	off	ON	ON	ON	ON
488	off	off	off	ON	off	ON	ON	ON	ON
489	ON	off	off	ON	off	ON	ON	ON	ON
490	off	ON	off	ON	off	ON	ON	ON	ON
491	ON	ON	off	ON	off	ON	ON	ON	ON
492	off	off	ON	ON	off	ON	ON	ON	ON
493	ON	off	ON	ON	off	ON	ON	ON	ON
494	off	ON	ON	ON	off	ON	ON	ON	ON
495	ON	ON	ON	ON	off	ON	ON	ON	ON
496	off	off	off	off	ON	ON	ON	ON	ON
497	ON	off	off	off	ON	ON	ON	ON	ON
498	off	ON	off	off	ON	ON	ON	ON	ON
499	ON	ON	off	off	ON	ON	ON	ON	ON
500	off	off	ON	off	ON	ON	ON	ON	ON
501	ON	off	ON	off	ON	ON	ON	ON	ON
502	off	ON	ON	off	ON	ON	ON	ON	ON
503	ON	ON	ON	off	ON	ON	ON	ON	ON
504	off	off	off	ON	ON	ON	ON	ON	ON
505	ON	off	off	ON	ON	ON	ON	ON	ON
506	off	ON	off	ON	ON	ON	ON	ON	ON
507	ON	ON	off	ON	ON	ON	ON	ON	ON
508	off	off	ON	ON	ON	ON	ON	ON	ON
509	ON	off	ON	ON	ON	ON	ON	ON	ON
510	off	ON	ON	ON	ON	ON	ON	ON	ON
511	ON	ON	ON	ON	ON	ON	ON	ON	ON

## Funzionamento automatico (stand alone)

Per fare funzionare il proiettore in modo automatico (STAND ALONE / MASTER), il dip-switch 12 deve essere in posizione di ON. Quando il proiettore viene acceso inizia ad eseguire le operazioni impostate tramite i dip-switches.

Se all'accensione il proiettore deve eseguire delle sequenze di colori il dip-switch 12 deve essere nella posizione di ON.

**ATTENZIONE:** Quando un proiettore funziona in modo automatico genera segnali DMX, bisogna scollegarlo da centraline DMX o altri proiettori MASTER in quanto si possono generare conflitti fra i segnali.

Tramite i dip-switches si può scegliere il tipo di sequenza che il proiettore effettuerà.

Dip-switch	FUNZIONE
Dip 1	Sequenza modo SQ1
Dip 2	Sequenza modo SQ2
Dip 3	Sequenza modo SQ3
Dip 4	OFF=Solo colori pieni ON=Abilita mezzi colori
Dip 5	OFF=Sequenze senza bianco ON=Abilita il bianco
Dip 6	OFF=Cambio color normale ON=Cambio colore rallentato
Dip 7	Tempo permanenza colore TIME 1
Dip 8	Tempo permanenza colore TIME 2
Dip 9	Tempo permanenza colore TIME 3
Dip 10	Tempo permanenza colore TIME 4
Dip 11	Tempo permanenza colore TIME 5
Dip 12	ON

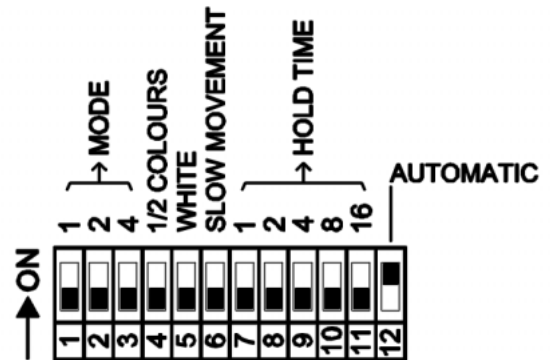

## SCELTA DELLA SEQUENZA DEI COLORI

I colori in tabella, vengono eseguiti in modo ciclico, dall'alto verso il basso e vice versa.

Dip 1	Dip 2	Dip 3	COLORI IN SEQUENZA CICLICA									
off	off	off	WHITE	COL 1	COL 2	COL 3	COL 4	COL 5	COL 4	COL 3	COL 2	COL 1
ON	off	off	WHITE	COL 1	COL 2	COL 3	COL 4	COL 3	COL 2	COL 1		
off	ON	off	WHITE	COL 1	COL 2	COL 3	COL 2	COL 1				
ON	ON	off	WHITE	COL 1	COL 2	COL 1						
off	off	ON	WHITE	COL 1								
ON	off	ON	WHITE	COL 2	COL 4	COL 3	COL 1					
off	ON	ON	WHITE	COL 3	COL 5	COL 3						
ON	ON	ON	WHITE	COL 1	COL 2	COL 5	COL 2	COL 1				

Nella tabella il bianco (white) è abilitato (dip 5 in posizione di ON)

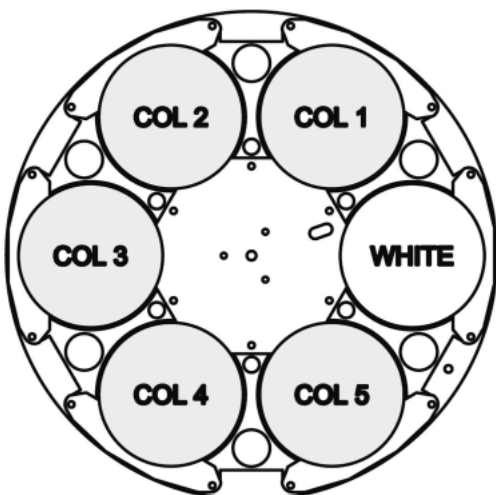

Filtri dicroici standard:

COL 1	COL 2	COL 3	COL 4	COL 5
ROSSO	GIALLO	VERDE	BLU	VIOLA

Disco colori visto dal lato frontale del proiettore

## SCELTA DEL TEMPO DI PERMANENZA DI UN COLORE

Tramite i dip-switches 7, 8, 9, 10, 11, si può scegliere il tempo di permanenza di tutti i colori.

Dip 7	Dip 8	Dip 9	Dip 10	Dip 11	Secondi	
off	off	off	off	off	5	
ON	off	off	off	off	10	
off	ON	off	off	off	15	
ON	ON	off	off	off	20	
off	off	ON	off	off	25	
ON	off	ON	off	off	30	
off	ON	ON	off	off	35	
ON	ON	ON	off	off	40	
off	off	off	ON	off	45	
ON	off	off	ON	off	50	
off	ON	off	ON	off	55	<b>Minuti</b>
ON	ON	off	ON	off		1
off	off	ON	ON	off		2
ON	off	ON	ON	off		3
off	ON	ON	ON	off		4
ON	ON	ON	ON	off		5
off	off	off	off	ON		10
ON	off	off	off	ON		15
off	ON	off	off	ON		20
ON	ON	off	off	ON		25
off	off	ON	off	ON		30
ON	off	ON	off	ON		35
off	ON	ON	off	ON		40
ON	ON	ON	off	ON		45
off	off	off	ON	ON		50
ON	off	off	ON	ON		55
off	ON	off	ON	ON		<b>Ore</b>
ON	ON	off	ON	ON		1
off	off	ON	ON	ON		2
ON	off	ON	ON	ON		3
off	ON	ON	ON	ON		4
ON	off	ON	ON	ON		6
off	ON	ON	ON	ON		8

## Cambio lampada

- Disconnettere il proiettore dall'alimentazione elettrica.
- Svitare le quattro viti del coperchio dell'alloggiamento della lampada.

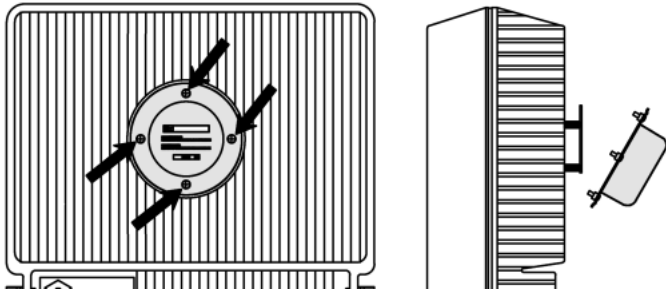

- Svitare e rimuovere le 3 viti del supporto lampada

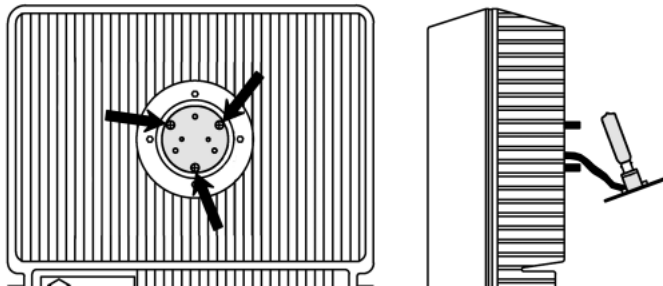

- Rimuovere la lampada, usando cura e guanti appropriati.
- Inserire la nuova lampada.
- Reinscrivere il supporto portalamпада.
- Fissare le tre viti che lo supportano.
- Reinscrivere il coperchio protettivo del comparto lampada.
- Fissare bene le quattro viti che lo sostengono.

Questo tipo di lampada ha una durata di 2000 ore (dati dei costruttori).  
Si consiglia di sostituirla prima di questa scadenza.

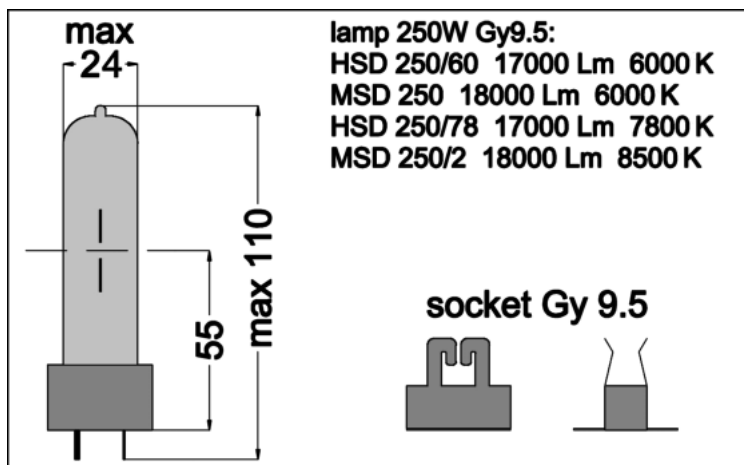

**LA LAMPADA A SCARICA CONTIENE SOSTANZE CHE POSSONO INQUINARE L'AMBIENTE,  
PERCIO', DEVE ESSERE ELIMINATA CON I RIFIUTI SPECIALI.**

## **Parti di ricambio**

Quando vengono ordinati pezzi di ricambio, è necessario menzionare il modello e il numero di serie del proiettore, sul retro del proiettore.

Chiamate il vostro rivenditore di zona per avere qualsiasi assistenza o direttamente il costruttore.

### **LISTA PEZZI DI RICAMBIO**

<b>CODICE</b>	<b>DESCRIZIONE</b>
<b>LP68</b>	<b>lampada a scarica 250W Gy9.5</b>
PL04	Porta lampada Gy 9.5
PAR46/25	Riflettore in alluminio, trattato, foro 24mm
TR57	Trasformatore 230/14V 10VA
AL01	Alimentatore VAG. 230V 50/60Hz 3.3A
CD01	Condensatore 31.5microF
ACC12	Accenditore per lampada 250/400W
17HD-24-AT	Stepper motor, per alte temperature
VOL05	Maniglia laterale nera in plastica
VOL66	Maniglia laterale grigia in plastica
5108141	Vetro frontale temperato, 263x306x5mm
OD150Z01	Coperchio comparto lampada con guarnizioni

L'uso improprio di questo proiettore inficia la garanzia e la nostra responsabilità. Tutti i dati sono stati redatti e controllati con la massima cura; non ci assumiamo in ogni caso alcuna responsabilità per eventuali errori od omissioni. Ci riserviamo il diritto di apporre modifiche e/o migliorie che ritenessimo necessarie, senza ulteriore preavviso. È vietata qualunque riproduzione di questo manuale, anche parziale, se non espressamente autorizzata.